



SERVICE MANUAL

MITSUBISHI ENGINE

TX25H

SERVICE MANUAL

MITSUBISHI ENGINE

INTERNATIONAL TRACTORS LIMITED

HOSHIARPUR, PUNJAB (INDIA)

Publication No : ITL/SM/ENG/04
Published on : Feb'18

CONTENTS

General	External view	D-2
	System flow diagrams	D-3
	Specifications	D-5
	Tips on disassembling and reassembling	D-8
Service Data	Maintenance service data	D-10
	Tightening torque table	D-14
Service tools	Basic tools	D-19
	Special tools	D-20
Determination of overhaul	Determining overhaul timing	D-22
	Testing compression pressure	D-23
Disassembly of basic engine	Disassembling and inspecting cylinder head and valve mechanism	D-25
	Disassembling and inspecting flywheel	D-28
	Disassembling and inspecting gear case, timing gear and camshaft	D-31
	Disassembling and inspecting cylinder block, crankshaft, piston and oil pan	D-35

CONTENTS

Inspection and repair of basic engine	Inspecting & repairing cylinder head & valve mechanism	D-40
	Inspecting and repairing flywheel	D-45
	Inspecting & repairing gear case, timing gear & camshaft	D-46
	Inspecting & repairing cylinder block, crankshaft & piston	D-49
Reassembly of basic engine	Reassembling cylinder block, crankshaft, piston and oil pan	D-58
	Reassembling flywheel, timing gear and camshaft	D-65
	Reassembling cylinder head and valve mechanism	D-69
	Removing fuel system	D-73
Fuel system	Disassembling, inspecting and reassembling fuel system	D-76
	Installing fuel system	D-89
Lubrication system	Removing lubrication system	D-93
	Disassembling, inspecting and reassembling lubrication system	D-95
	Installing lubrication system	D-97
Cooling system	Removing cooling system	D-100
	Disassembling, inspecting & reassembling cooling system	D-101
	Installing cooling system	D-103
Inlet and exhaust system	Removing inlet and exhaust systems	D-105
	Disassembling, inspecting & reassembling inlet & exhaust systems	D-106
	Installing inlet and exhaust systems	D-107
Electrical system	Removing electrical system	D-110
	Disassembling, inspecting & reassembling electrical system	D-116
	Installing electrical system	D-129

CONTENTS

Adjustment and operation	Inspection and adjustment of engine	D-137
	Break-in operation	D-142
	Performance test (JIS standard)	D-143
Troubleshooting	Troubleshooting	D-146

GENERAL

1. External view	D-1-2
2. System flow diagrams	D-1-4
2.1 Fuel system - flow diagram	D-1-4
2.2 Lubrication system - flow diagram	D-1-4
2.3 Cooling system - flow diagram	D-1-5
2.4 Inlet and exhaust system - flow diagram	D-1-5
4. Specifications	D-1-7
5. Tips on disassembling and reassembling	D-1-10
5.1 Disassembling	D-1-10
5.2 Reassembling	D-1-10

GENERAL

1. External View

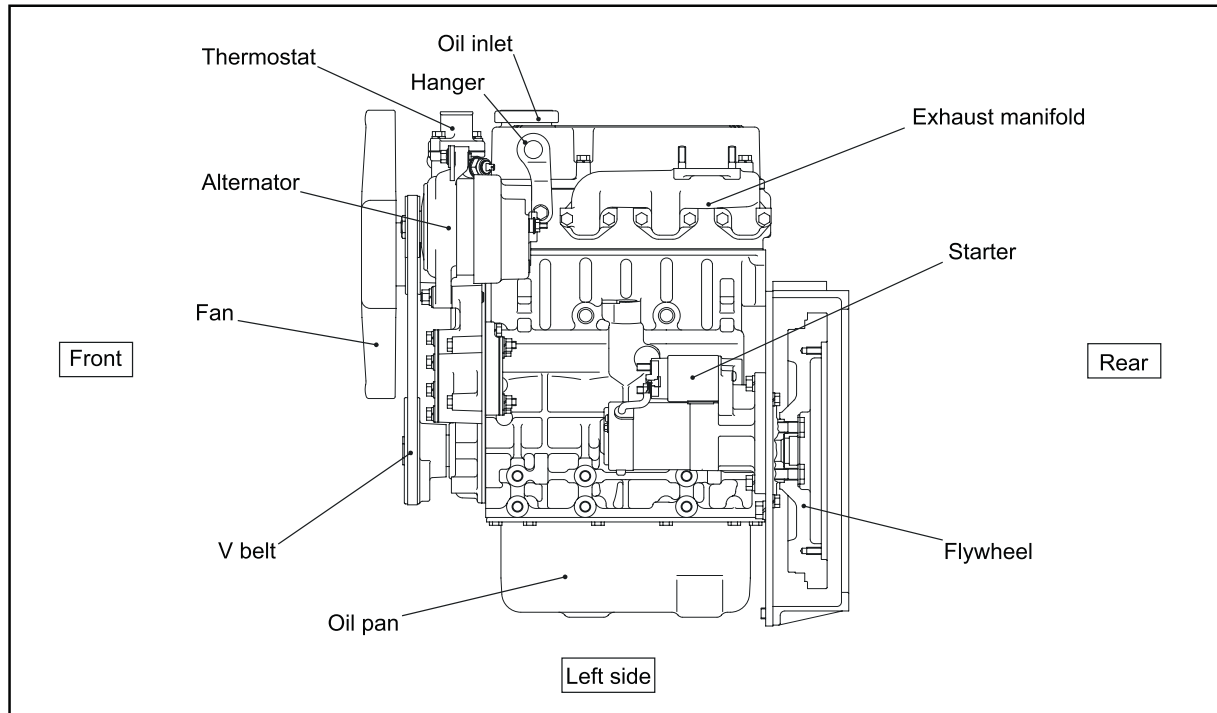

Engine left view

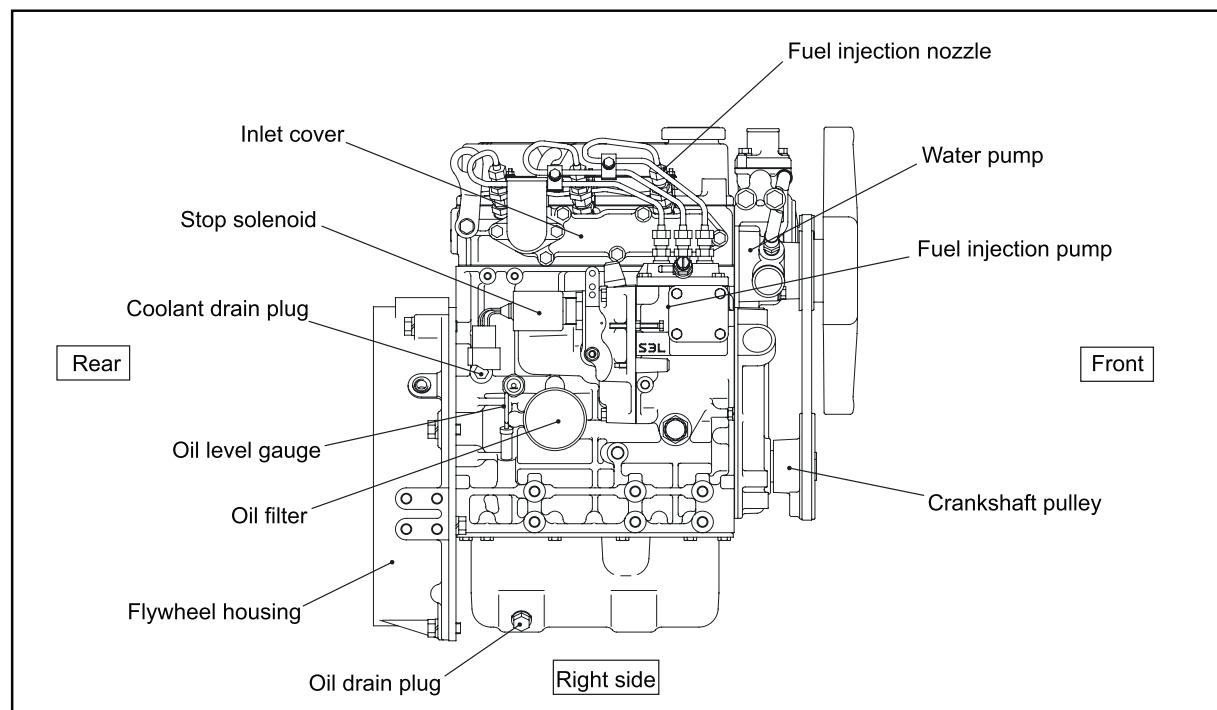

Engine right view

GENERAL

2. System Flow Diagrams

2.1 Fuel System - Flow Diagram

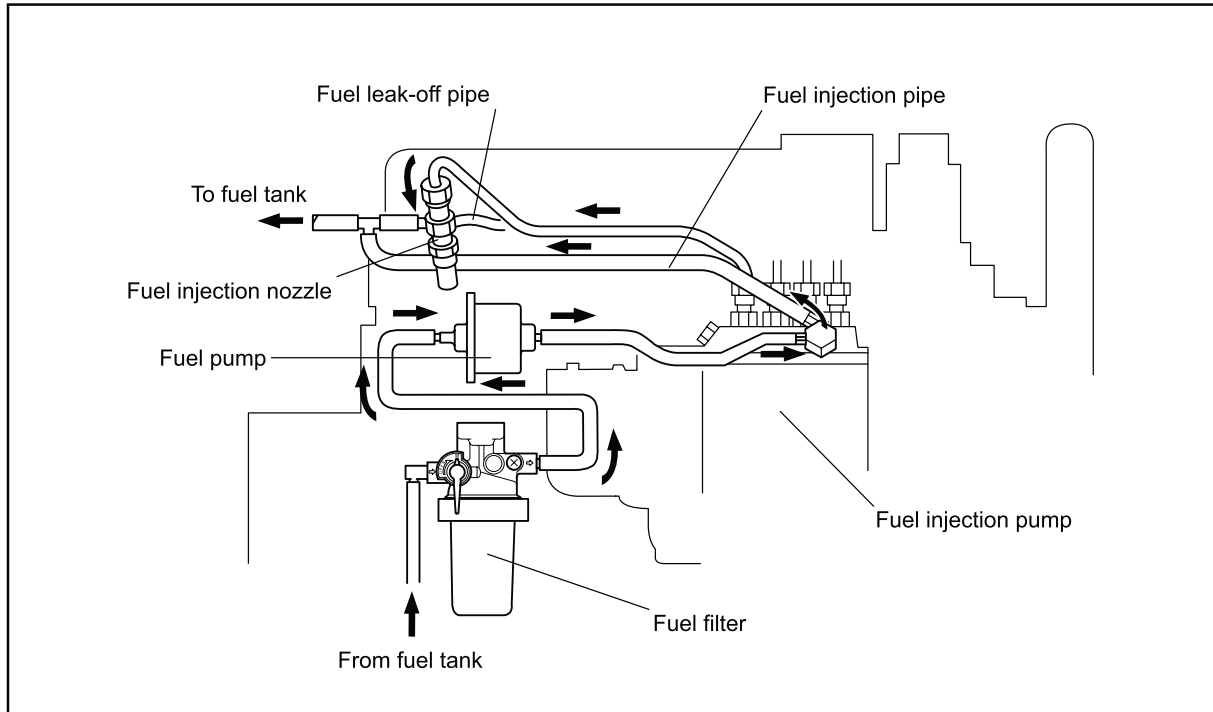

Fuel system - flow diagram

2.2 Lubrication System - Flow Diagram

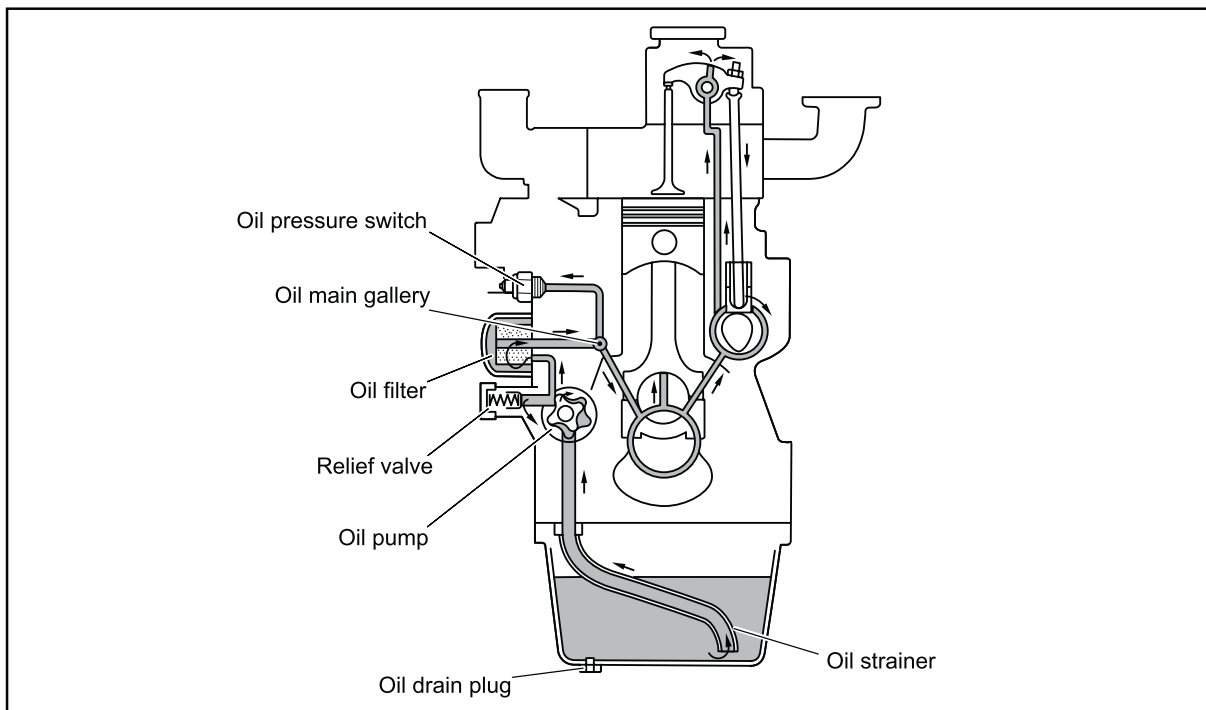

Lubrication system - flow diagram

GENERAL

2.3 Cooling System - Flow Diagram

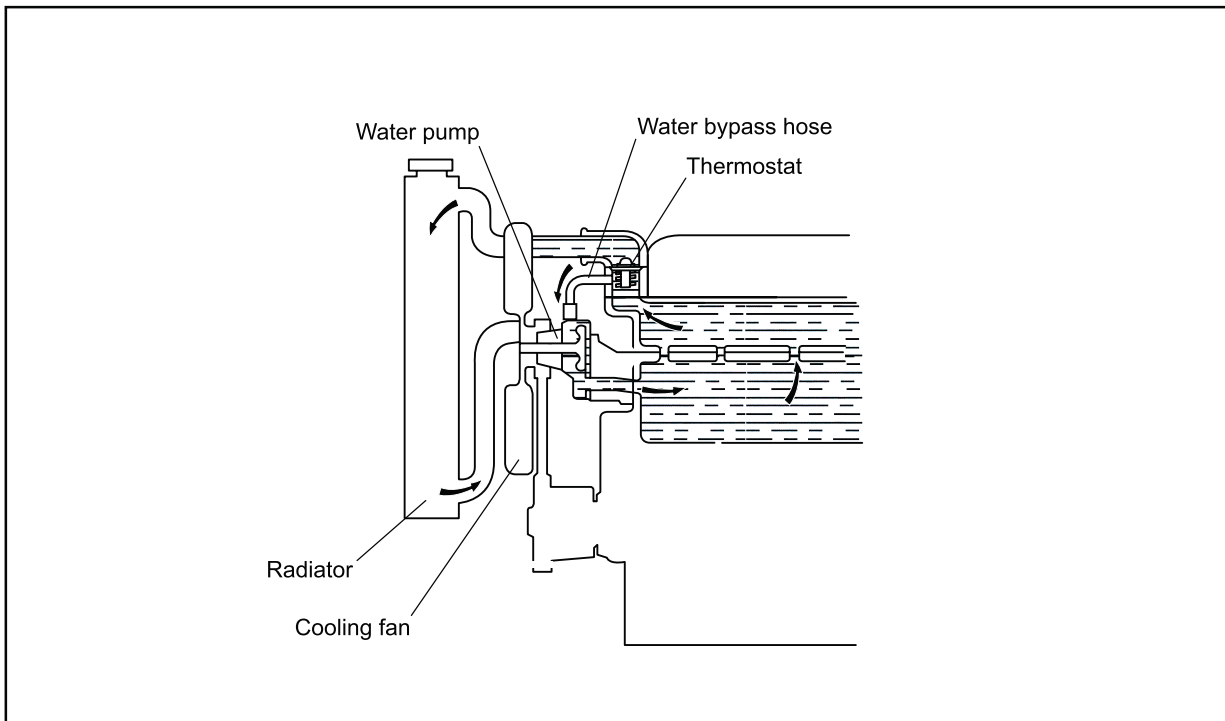

Cooling system - flow diagram

2.4 Inlet & Exhaust System - Flow Diagram

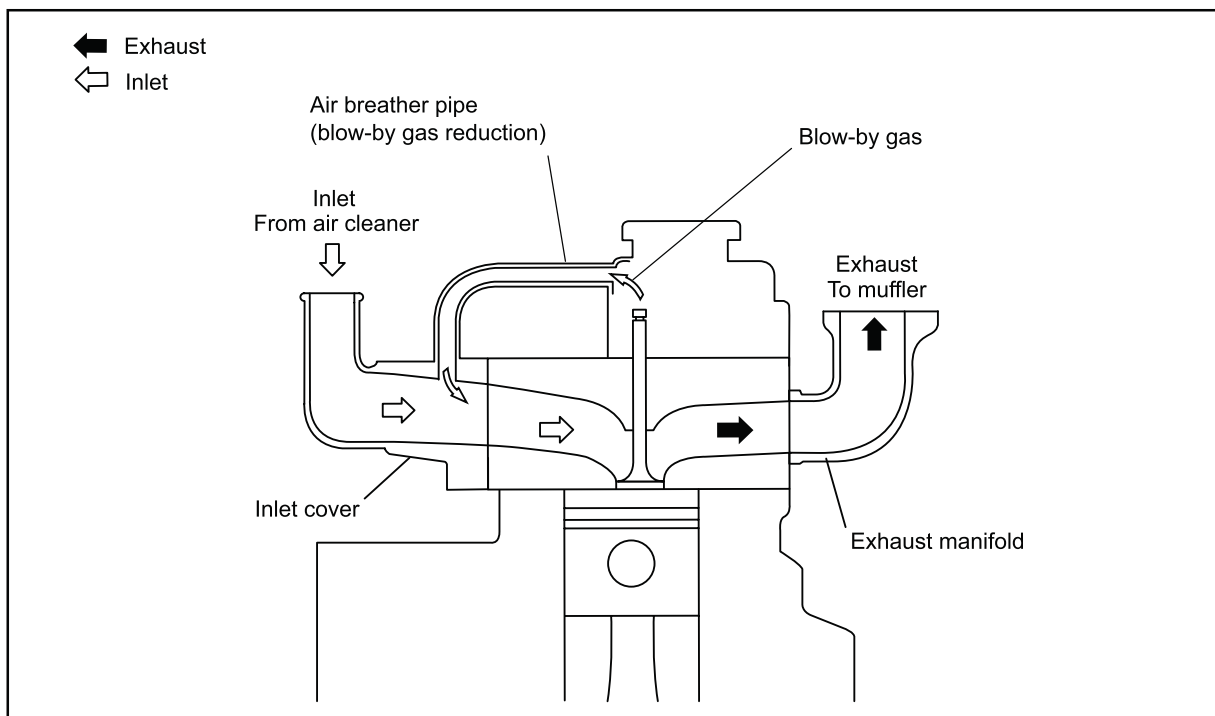

Inlet and exhaust system - flow diagram

GENERAL

3. Specifications

Engine model		S3L2		
Main specifications	Type		Water Cooled, 4-Stroke cycle diesel	
	No of Cylinders		3	
	Combustion type		Swirl Chamber type	
	Valve mechanism		Overhead Valve type	
	Cylinder bore×stroke		78 x 92 mm [3.07 x 3.62 in.]	
	Total displacement		1.318 L [0.348 U.S. gal.]	
	Compression ratio		22:1	
	Fuel used		JISK2204, Diesel oil or its equivalent (ASTM D975, etc)	
	Order of ignition		1 - 3 - 2	
	Direction of rotation		Counterclockwise as viewed from flywheel side	
	Dimension	Length	536 mm [21.10 in.]	
		Width	433mm [17.05 in.]	
		Height	572 mm [22.52 in.]	
Dry mass		Appx. 140 kg [309 lb]		
Main unit of engine	Piston ring	Number	Compression rings: 2	
			Oil ring (with expander): 1	
	Valve timing (when warm)	Inlet valve	Open	BTDC 15°
			Close	ABDC 41°
		Exhaust valve	Open	BBDC 54°
			Close	ATDC 10°
	Engine support method		4-Point support	
	Starting system		Starter	

GENERAL

3. Specifications

Engine model			S3L2
Fuel system	Fuel injection pump	Type	Bosch M type
		Manufacturer	DENSO corporation
		Plunger diameter	ø 5.5 mm [0.217 in.] or ø 6.0 mm [0.236 in.]
		MS retard (crank angle)	4°, 8° or no setting
		Cam lift	15 mm [0.59 in.]
	Governor	Speed governing type	Centrifugal weight system
	Fuel injection nozzle	Type	Throttle type
		Manufacturer	DENSO corporation
		Spray angle	15°
		Valve opening pressure	13.73 MPa {140 kgf/cm ² } [1991 psi]
Fuel filter	Type	Paper-element cartridge	
Lubrication system	Lubrication system		Pressure feed, full flow filter system
	Engine oil	Specification	SAE 15W40
		Capacity	Standard oil pan
	Oil pump	Type	Gear pump
		Discharge rate	18 L [4.76 U.S. gal]/min
	Relief valve	Type	Piston valve type
		Valve opening pressure	0.3 to 0.4 MPa {3 to 4 kgf/cm ² } [43 to 57 psi]
Oil filter	Type	Paper element type	
Cooling system	Cooling system		Forced-feed circulation type
	Coolant capacity (main unit of engine)		1.8 L [0.48 U.S. gal]
	Water pump	Type	Centrifugal volute type
		Discharge rate	30 L [7.93 U.S. gal]/min (at engine speed 2000 min ⁻¹)
	Thermostat	Type	Wax pellet
Valve opening pressure		82 ± 1.5 °C [179.6 ± 2.7°F]	
Inlet exhaust system	Air cleaner	Type	Dry Air Cleaner

GENERAL

3. Specifications

Engine model		S3L2	
Electrical system	Glow plug	Type	Sheathed
		Rated voltage-current	12 V
			24 V
	Stop solenoid	Working voltage	Run off type (ETS:Energized to stop)
			Run off type (ETR:Energized to rum)
		Insulation resistance	100 M Ω or more at DC 500 V megger (normal temperature, normal relative humidity)
Stroke	13.5 \pm 0.5 mm [0.532 \pm 0.020 in.]		

4. Tips on disassembling and reassembling

This service manual specifies the recommended procedures to be followed when servicing Mitsubishi engines. The manual also specifies the special tools that are required for the work, and the basic safety precautions to follow when working.

Note that this manual does not exhaustively cover potential hazards that could occur during maintenance, inspection and service work of engine.

When working on an engine, follow the relevant directions given in this manual and observe the following instructions:

5.1 Disassembling

- (1) Use correct tools and instruments. Serious injury or damage to the engine will result from using the wrong tools and instruments.
- (2) Use an overhaul stand or work bench if necessary, and follow the disassembling procedures described in this manual.
- (3) Keep the engine parts in order of removal to prevent losing them.
- (4) Pay attention to assembling marks. Put your marks on the parts, if necessary, to ensure correct reassembling.
- (5) Carefully check each part for defects during disassembling or cleaning. Do not miss symptoms which can not be detected after disassembling or cleaning.
- (6) When lifting or carrying heavy parts, exercise utmost caution to ensure safety. Pay attention to balance of heavy parts when handling. (Get help, and use jacks, chain blocks and guide bolts as necessary.)

5.2 Reassembling

- (1) Wash all engine parts, except such parts as oil seals, O-rings and rubber sheets, in cleaning oil and dry them with compressed air.
- (2) Use correct tools and instruments.
- (3) Use only high-quality lubricating oils and greases of appropriate types. Be sure to apply oil, grease or adhesive to the part wherever specified.
- (4) Use a torque wrench to tighten parts correctly when their tightening torques are specified.
Refer to "List of Tightening Torque."
- (5) Replace all gaskets and packings with new ones unless specified otherwise. Apply adhesive if necessary. Use

only the proper amount of adhesive.

SERVICE DATA

1. Maintenance service data	2-2
1.1 General	2-2
1.2 Basic engine	2-2
1.3 Fuel system	2-5
1.4 Lubrication system	2-5
1.5 Cooling system	2-5
1.6 Inlet and Exhaust system	2-5
2. Tightening torque table	2-7
2.1 Major bolt tightening torque	2-7
2.1.1 Basic Engines	2-7
2.1.2 Fuel System	2-8
2.1.3 Lubrication System	2-8
2.1.4 Cooling system	2-8
2.1.5 Inlet and exhaust systems	2-8
2.1.6 Electrical system	2-8
2.2 Standard bolt and nut tightening torque	2-9
2.3 Standard eyebolt tightening torque	2-10
2.4 Standard union nut tightening torque	2-10

SERVICE DATA

1. Maintenance service data

1.1 General

Table 2-1 Maintenance service data table - General

Unit: mm [in.]

Inspection point		Nominal	Standard	Limit	Remark
Maximum rotation speed (rated rotation speed used as reference)		(Varies depending on specification of destination)			
Minimum rotation speed					
Compression pressure (at 290 min ⁻¹)			2.9 MPa {30 kgf/cm ² } [421 psi] or above	2.6 MPa {27 kgf/cm ² } [377 psi] or less	When oil and water temperatures at 20 to 30°C [68 to 86°F]
Lubricating oil pressure	Rotated speed		0.29 to 0.39 MPa {3.0 to 4.0 kgf/cm ² } [42 to 57 psi]		Oil temperature at 60 to 70°C [140 to 158°F]
	Low idling speed		0.098 MPa {1.0 kgf/cm ² } [14 psi]		
Valve timing	Inlet	open		BTDC 15°	With 2 mm [0.079 in.] clearance on valve side, when cold. Values are only for checking valve timing and are different from the actual ones.
		closes		ABDC 41°	
	Exhaust	open		BBDC 54°	
		closes		ATDC 10°	
Valve clearance	Inlet		0.25 [0.0098]		When engine is cold
	Exhaust		0.25 [0.0098]		
Fuel injection timing (before TDC)			17°		

1.2 Basic engine

Table 2-2 Maintenance service data table - Basic engine (1 / 3)

Unit: mm [in.]

Inspection point		Nominal	Standard	Limit	Remark	
Rocker arm	Rocker arm inside diameter	ø 18.9 [0.744]	18.910 to 18.930 [0.7445 to 0.7453]			
	Rocker shaft outside diameter	ø 18.9 [0.744]	18.880 to 18.898 [0.7433 to 0.7440]			
	Clearance between rocker arm and rocker shaft (oil clearance)		0.012 to 0.050 [0.0005 to 0.0020]	0.200 [0.0079]	Replace rocker arm	
Valve	Valve stem outside diameter	Inlet	ø 6.6 [0.260]	6.565 to 6.580 [0.2585 to 0.2591]	6.500 [0.2559]	
		Exhaust	ø 6.6 [0.260]	6.530 to 6.550 [0.2571 to 0.2579]	6.500 [0.2559]	
	Valve guide inside diameter	Inlet	ø 6.6 [0.260]	6.600 to 6.615 [0.2600 to 0.2604]		
		Exhaust	ø 6.6 [0.260]	6.600 to 6.615 [0.2600 to 0.2604]		
	Clearance between valve stem and valve guide	Inlet		0.020 to 0.050 [0.0008 to 0.0020]	0.100 [0.0039]	Replace valve and valve guide
		Exhaust		0.050 to 0.085 [0.0020 to 0.0033]	0.150 [0.0059]	

SERVICE DATA

Table 2-2 Maintenance service data table - Basic engine (2 / 3)

Unit: mm [in.]

Inspection point		Nominal	Standard	Limit	Remark	
Valve seat and valve	Valve seat angle	45°				
	Valve sinkage	0 [0.00]	0.25 to 0.75 [0.0098 to 0.0295]	1.50 [0.0591]		
	Valve head width	1.6 [0.063]	1.30 to 1.80 [0.0512 to 0.0709]	2.50 [0.0984]		
	Valve margin	1.5 [0.059]	1.35 to 1.65 [0.0531 to 0.0650]	0.50 [0.0197]		
	Valve guide mounting length	10 [0.39]	9.5 to 10.5 [0.374 to 0.413]			
Valve spring	Free length		47 [1.85]	46 [1.81]		
	Squareness		$\theta = 2.0^\circ$ $\Delta = 0.2$ [0.0079] or less $L_f = 47$ [1.85]	$\Delta = 0.5$ [0.020] over entire length		
	Rest length / load		39.0 [1.535]/ 131 to 145 N {13.3 to 14.7 kgf} {29 to 32 lbf}	30.1 [1.185]/ 279 to 309 N {28.5 to 31.5 kgf} [63 to 69 lbf]		-15%
Pushrod	Runout		0.3 [0.012] or less		Replace	
Cylinder head	Distortion of cylinder head bottom surface		0.05 [0.0020] or less	0.10 [0.0039]	Repair	
Cylinder	Distortion of block top surface		0.05 [0.0020] or less	0.10 [0.0039]	Repair	
	Inside diameter	$\varnothing 78$ [3.073]	$\varnothing 78^{+0.060}_{-0.030}$ [3.07 ^{+0.0024} _{+0.0012}]	78.2 [3.079]	Repair to oversize or replace	
	Cylindricity		±0.01 [0.0004] or less			
Piston	Outside diameter	STD	78.00 [3.0709]	77.93 to 77.95 [3.0681 to 3.0689]	77.80 [3.0630]	
		0.25 OS	78.25 [3.0807]	78.18 to 78.20 [3.0779 to 3.0787]	78.05 [3.0728]	
		0.50 OS	78.50 [3.0905]	78.43 to 78.45 [3.0878 to 3.0886]	78.30 [3.0827]	
	Weight difference in one engine		±5 g [0.18 oz.] or less			
	Piston pin outside diameter	$\varnothing 23$ [0.91]	22.994 to 23.000 [0.9053 to 0.9055]			
	Clearance between piston pin bore and piston pin		0.006 to 0.018 [0.0002 to 0.0007]	0.050 [0.0020]		
Clearance between piston and cylinder (clearance)		0.035 to 0.086 [0.0014 to 0.0034]	0.300 [0.0120]	Repair to oversize or replace		

SERVICE DATA

Table 2-2 Maintenance service data table - Basic engine (3 / 3)

Unit: mm [in.]

Inspection point		Nominal	Standard	Limit	Remark	
Piston ring	Clearance between piston ring and ring groove	No.1 compression ring	0.09 to 0.11 [0.0035 to 0.0043]	0.30 [0.0118]	Use the piston with replacing the piston rings until reaching the limits. when reaching the limits, replace the piston.	
		No.2 compression ring	0.07 to 0.11 [0.0028 to 0.0043]	0.20 [0.0079]		
		Oil ring	0.03 to 0.07 [0.0012 to 0.0028]	0.20 [0.0079]		
	Piston ring end gap	No.1 compression ring	0.15 to 0.30 [0.0059 to 0.0118]	1.50 [0.0591]		Replace
		No.2 compression ring	0.15 to 0.35 [0.0059 to 0.0138]			
		Oil ring	0.20 to 0.40 [0.0079 to 0.0157]			
Connecting rod	Bend and torsion		0.05/100 [0.0020/3.94] or less	0.15/100 [0.0059/3.94]		
	End play		0.10 to 0.35 [0.0039 to 0.0138]	0.50 [0.0197]	Replace connecting rod	
Crankshaft	Crank journal outside diameter		∅ 52 [2.05]	51.985 to 52.000 [2.0466 to 2.0472]		
	Crank pin outside diameter		∅ 48 [1.89]	47.950 to 47.965 [1.8878 to 1.8883]		
	Crankshaft runout			0.025 [0.0010] or less	0.050 [0.0020]	Repair or replace
	Main bearing oil clearance			0.030 to 0.077 0.0012 to 0.0030	0.100 [0.0039]	Replace main bearing
	Connecting rod bearings oil clearance			0.025 to 0.072 [0.0010 to 0.0028]	0.150 [0.0059]	Replace connecting rod bearings
	End play			0.050 to 0.175 [0.0020 to 0.0069]	0.500 [0.0197]	Replace flanged No.3 main bearings
Timing gear backlash	Between crankshaft gear and idler gear		0.04 to 0.12 [0.0016 to 0.0047]	0.30 [0.0118]	Replace	
	Between idler gear and valve camshaft gear					
	Between idler gear and pump camshaft gear					
	Between valve camshaft gear and PTO gear		0.08 to 0.19 [0.0031 to 0.0075]			
	Between pump camshaft gear and oil pump gear		0.07 to 0.20 [0.0028 to 0.0079]			
Cam height of camshaft (major axis)			35.62 to 35.82 [1.4024 to 1.4102]	34.72 [1.3669]	Replace	
Cam height of fuel injection pump camshaft (major axis)			43.9 to 44.1 [1.728 to 1.736]	43 [1.69]	Replace	
Flywheel flatness			0.15 [0.0059] or less	0.50 [0.0197]	Repair	
Clearance between tappet and cylinder block bore				0.15 [0.0059]	Replace tappet	
Clearance between camshaft journal and bushing			0.05 to 0.125 [0.0020 to 0.0049]	0.15 [0.0059]	Replace	
Clearance between idler gear bushing and idler shaft			0.02 to 0.07 [0.0008 to 0.0028]	0.20 [0.0079]	Replace idler gear or idler shaft	

SERVICE DATA

1.3 Fuel system

Table 2-3 Maintenance service data table - Fuel system

Unit: mm [in.]

Inspection point		Nominal	Standard	Limit	Remark
Fuel injection nozzle	Valve opening pressure	13.73 MPa {140 kgf/cm ² } [1991 psi]	14.22 to 15.00 MPa {145 to 153 kgf/cm ² } [2062 to 2176 psi]		Adjust with washers Standard is new parts value.

1.4 Lubrication system

Table 2-4 Maintenance service data table - Lubrication system

Unit: mm [in.]

Inspection point		Nominal	Standard	Limit	Remark
Relief valve opening pressure			0.3 to 0.4 MPa {3 to 4 kgf/cm ² } [43 to 57 psi]		Replace
Oil pressure at which oil pressure switch illuminates			0.04 to 0.06 MPa {0.4 to 0.6 kgf/cm ² } [5.6 to 8.4 psi]		Replace

1.5 Cooling system

Table 2-5 Maintenance service data table - Cooling system

Unit: mm [in.]

Inspection point		Nominal	Standard	Limit	Remark
Thermostat	Temperature at which valve starts opening		82 ± 1.5°C [179.6 ± 2.7°F]		Replace
	Temperature at which valve lift becomes 8 [0.32] or more		95°C [203°F]		
Thermoswitch	At 111 ± 3.5°C [231.8 ± 6.3°F]		30 mΩ (in oil of 105°C [221°F])		Replace
Deflection amount of belt (when it is pushed between crankshaft pulley and alternator pulley with a force of approx. 98 N {10 kgf} [22.03 lbf])			10 to 12 [0.39 to 0.47]		

1.6 Inlet and Exhaust system

Table 2-6 Maintenance service data table - Inlet and Exhaust system

Unit: mm [in.]

Inspection point		Nominal	Standard	Limit	Remark
Distortion on mounting surfaces of intake cover and exhaust manifold				0.15 [0.0059] or less	Repair by grinding or replace

SERVICE DATA

2. Tightening torque table

2.1 Major bolt tightening torque

2.1.1 Basic engines

Table 2-8 Tightening torque list - Basic engines

Description	Threads Dia × Pitch (mm)	Torque			Remark	
		N·m	kgf·m	lbf·ft		
Cylinder head bolt	M10 × 1.75	83.4 to 93.2	8.5 to 9.5	61.5 to 68.7		
Rocker cover bolt	M8 × 1.25	9.81 to 12.7	1.0 to 1.3	7.2 to 9.4		
Rocker shaft bracket bolt	M8 × 1.25	9.81 to 19.6	1.0 to 2.0	7.2 to 14.5		
Rocker arm adjusting nut	M8 × 1.25	18.0 to 22.0	1.8 to 2.2	13.0 to 15.9		
Tachometer L joint union nut	M22 × 1.5	16.7 to 22.6	1.7 to 2.3	12.3 to 16.6		
Band type hose cramp	-	2.9 to 3.4	0.3 to 0.35	2.2 to 2.5		
Thrust plate	M8 × 1.25	9.8 to 11.8	1.0 to 1.2	7.2 to 8.7		
Main bearing cap bolt	M10 × 1.25	49.0 to 53.9	5.0 to 5.5	36.2 to 39.8		
Connecting rod cap nut	M9 × 1.0	32.4 to 37.3	3.3 to 3.8	23.9 to 27.5		
Flywheel bolt	M12 × 1.25	127 to 137	13.0 to 14.0	94.0 to 101.3		
Crankshaft pulley nut	M18 × 1.5	147 to 196	15.0 to 20.0	108.5 to 144.6		
Rear plate mounting bolt	For gen- eral use	M12 × 1.25	53.9 to 73.5	5.5 to 7.5	39.8 to 54.2	Equivalent to 7T
	For tractor	M12 × 1.25	83.4 to 103	8.5 to 10.5	61.5 to 75.9	

2.1.2 Fuel system

Table 2-9 Tightening torque list - Fuel system

Description	Threads Dia × Pitch (mm)	Torque			Remark
		N·m	kgf·m	lbf·ft	
Hollow screw (fuel injection pump)	M12 × 1.25	14.7 to 19.6	1.5 to 2.0	10.8 to 14.5	
	M14 × 1.5	19.6 to 24.5	2.0 to 2.5	14.5 to 18.1	
Delivery valve holder (fuel injection pump)	-	39.2 to 49.0	4.0 to 5.0	28.9 to 36.1	
Air-bleeding plug (fuel injection pump)	M8 × 1.25	9.81 to 13.7	1.0 to 1.4	7.2 to 10.1	
Nozzle retaining nut	M16 × 0.75	34.3 to 39.2	3.5 to 4.0	25.3 to 28.9	
Nozzle holder	M20 × 1.5	49.0 to 58.8	5.0 to 6.0	36.2 to 43.4	
Fuel injection pipe nut	M12 × 1.5	24.5 to 34.3	2.5 to 3.5	18.1 to 25.3	
Fuel leak-off pipe nut	M12 × 1.5	20.6 to 24.5	2.1 to 2.5	15.2 to 18.1	
Sliding sleeve shaft	M10 × 1.25	29.4 to 41.2	3.0 to 4.2	21.7 to 30.4	
Torque spring set special nut	M12 × 1.0	14.7 to 24.5	1.5 to 2.5	10.8 to 18.1	

SERVICE DATA

2.1.3 Lubrication system

Table 2-10 Tightening torque list - Lubrication system

Description	Threads Dia × Pitch (mm)	Torque			Remark	
		N·m	kgf·m	lbf·ft		
Oil relief valve	M22 × 1.5	44.1 to 53.9	4.5 to 5.5	32.5 to 39.8		
Oil pan drain plug	M14 × 1.5	34.3 to 44.1	3.5 to 4.5	25.3 to 32.5		
Oil filter	M20 × 1.5	10.8 to 12.7	1.1 to 1.3	8.0 to 9.4		
Oil cooler connector	M20 × 1.5	58.8 to 78.5	6.0 to 8.0	43.4 to 57.9		
Turbocharger lubricating oil pipe mounting bolt	M10 × 1.25	13.7 to 18.6	1.4 to 1.9	10.1 to 13.7		
Oil pressure switch	PT 1/8	7.85 to 11.8	0.8 to 1.2	5.8 to 8.7		
Oil pan mounting bolt	Press oil pan	M8 × 1.25	9.80 to 12.7	1.0 to 1.3	7.2 to 9.4	Equivalent to 4T
	Cast oil pan	M8 × 1.25	24.5 to 30.4	2.5 to 3.1	18.1 to 22.4	
Oil strainer nut	M16 × 1.5	24.5 to 29.4	2.5 to 3.0	18.1 to 21.7		

2.1.4 Cooling system

Table 2-11 Tightening torque list - Cooling system

Description	Threads Dia × Pitch (mm)	Torque			Remark
		N·m	kgf·m	lbf·ft	
Thermoswitch	M16 × 1.5	18.6 to 26.5	1.9 to 2.7	13.7 to 19.6	
Thermostat cover bolt	M8 × 1.25	16 to 20	1.6 to 2.0	11.8 to 14.8	
Thermo case bolt	M16 × 1.5	39.2 to 49.0	4.0 to 5.0	28.9 to 36.1	

2.1.5 Inlet and exhaust systems

Table 2-12 Tightening torque list - Inlet and exhaust systems

Description	Threads Dia × Pitch (mm)	Torque			Remark
		N·m	kgf·m	lbf·ft	
Inlet cover bolt	M8 × 1.25	14.7 to 21.6	1.5 to 2.2	10.8 to 15.9	
Exhaust manifold bolt	M8 × 1.25	14.7 to 21.6	1.5 to 2.2	10.8 to 15.9	
Turbocharger mounting bolt, nut	M8 × 1.25	24.5 to 29.4	2.5 to 3.0	18.1 to 21.7	

2.1.6 Electrical system

Table 2-13 Tightening torque list - Electrical system

Description	Threads Dia × Pitch (mm)	Torque			Remark
		N·m	kgf·m	lbf·ft	
Starter terminal B	M8 × 1.25	9.81 to 11.8	1.0 to 1.2	7.2 to 8.7	
Stop solenoid fixing nut	M30 × 1.5	39.2 to 49.0	4.0 to 5.0	28.9 to 36.2	
Stop solenoid blind plug	M30 × 1.5	39.2 to 49.0	4.0 to 5.0	28.9 to 36.2	
Glow plug	M10 × 1.25	14.7 to 19.6	1.5 to 2.0	10.8 to 14.5	
Glow plug connection plate fixing nut	M4 × 0.7	0.98 to 1.47	0.1 to 0.15	0.7 to 1.1	
Alternator terminal B	M5 × 0.8	2.9 to 4.9	0.3 to 0.5	2.2 to 3.6	
	M6 × 1.0	3.9 to 5.9	0.4 to 0.6	2.9 to 4.3	
	M8 × 1.25	6.9 to 12.7	0.7 to 1.3	5.1 to 9.4	

SERVICE DATA

2.2 Standard bolt and nut tightening torque

Table 2-14 Standard bolt and nut tightening torque

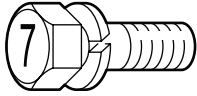
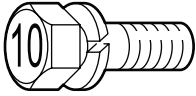
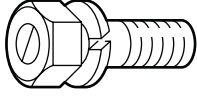
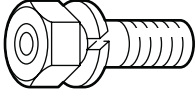
Description	Threads Dia Pitch (mm)	Width across flats (mm) [in.]	Strength classification							
			7T			10.9				
Metric automobile screw thread										
			N·m	kgf·m	lbf·ft	N·m	kgf·m	lbf·ft		
			M8 × 1.25	12 [0.47]	17	1.7	13	30	3.1	22
			M10 × 1.25	14 [0.55]	33	3.4	24	60	6.1	44
			M12 × 1.25	17 [0.67]	60	6.1	44	108	11.0	80
			M14 × 1.5	22 [0.87]	97	9.9	72	176	17.9	130
			M16 × 1.5	24 [0.94]	145	14.8	107	262	26.7	193
			M18 × 1.5	27 [1.06]	210	21.4	155	378	38.5	279
			M20 × 1.5	30 [1.18]	291	29.7	215	524	53.4	386
			M22 × 1.5	32 [1.26]	385	39.3	284	694	70.8	512
M24 × 1.5	36 [1.42]	487	49.7	359	878	89.5	648			
M27 × 1.5	41 [1.61]	738	75.3	544	1328	135.5	979			
Metric course screw thread										
			N·m	kgf·m	lbf·ft	N·m	kgf·m	lbf·ft		
			M10 × 1.5	14 [0.55]	32	3.3	24	58	5.9	43
			M12 × 1.75	17 [0.67]	57	5.8	42	102	10.4	75
			M14 × 2	22 [0.87]	93	9.5	69	167	17.0	123
			M16 × 2	24 [0.94]	139	14.2	103	251	25.6	185
			M18 × 2.5	27 [1.06]	194	19.8	143	350	35.7	258
			M20 × 2.5	30 [1.18]	272	27.7	201	489	49.9	361
			M22 × 2.5	32 [1.26]	363	37.0	268	653	66.6	482
			M24 × 3	36 [1.42]	468	47.7	345	843	86.0	622
M27 × 3	41 [1.61]	686	70.0	506	1236	126.0	912			

- Note: (a) This table lists the tightening torque for standard bolts and nuts.
 (b) The numerical values in the table are for fasteners with spring washers.
 (c) The table shows the standard values with a maximum tolerance value of $\pm 10\%$.
 (d) Use the tightening torque in this table unless otherwise specified.
 (e) Do not apply oil to threaded portions. (Dry)

SERVICE DATA

2.3 Standard eyebolt tightening torque

Table 2-15 Standard eyebolt tightening torque

Threads Dia × Pitch (mm)	Width across flats (mm) [in.]	Strength classification		
		4T		
		N·m	kgf·m	lbf·ft
M8 × 1.25	12 [0.47]	8 ± 1	0.8 ± 0.1	6 ± 0.7
M10 × 1.25	14 [0.55]	15 ± 2	1.5 ± 0.2	11 ± 1.5
M12 × 1.25	17 [0.67]	25 ± 3	2.5 ± 0.3	18 ± 2.2
M14 × 1.5	19 [0.75]	34 ± 4	3.5 ± 0.4	25 ± 3.0
M16 × 1.5	22 [0.87]	44 ± 5	4.5 ± 0.5	32 ± 3.7
M18 × 1.5	24 [0.94]	74 ± 5	7.5 ± 0.5	55 ± 3.7
M20 × 1.5	27 [1.06]	98 ± 10	10.0 ± 1.0	72 ± 7.4
M24 × 1.5	32 [1.26]	147 ± 15	15.0 ± 1.5	108 ± 11.1
M27 × 1.5	41 [1.61]	226 ± 20	23.0 ± 2.0	167 ± 14.8

(Dry)

2.4 Standard union nut tightening torque

Table 2-16 Standard union nut tightening torque

Nominal diameter	Cap nut size M (mm)	Width across flats (mm) [in.]	N·m	kgf·m	lbf·ft
63	M14 × 1.5	19 [0.75]	39	4	29
80	M16 × 1.5	22 [0.87]	49	5	36
100	M20 × 1.5	27 [1.06]	78	8	58
120	M22 × 1.5	30 [1.18]	98	10	72
150	M27 × 1.5	32 [1.26]	157	16	116
180	M30 × 1.5	36 [1.42]	196	20	145
200	M30 × 1.5	36 [1.42]	196	20	145
220	M33 × 1.5	41 [1.61]	245	25	181
254	M36 × 1.5	41 [1.61]	294	30	217

(Maximum tolerance value: ±10%, dry condition)

SERVICE TOOLS

1. Basic Tools	3-2
2. Special Tools	3-3

SERVICE TOOLS

1. Basic tools

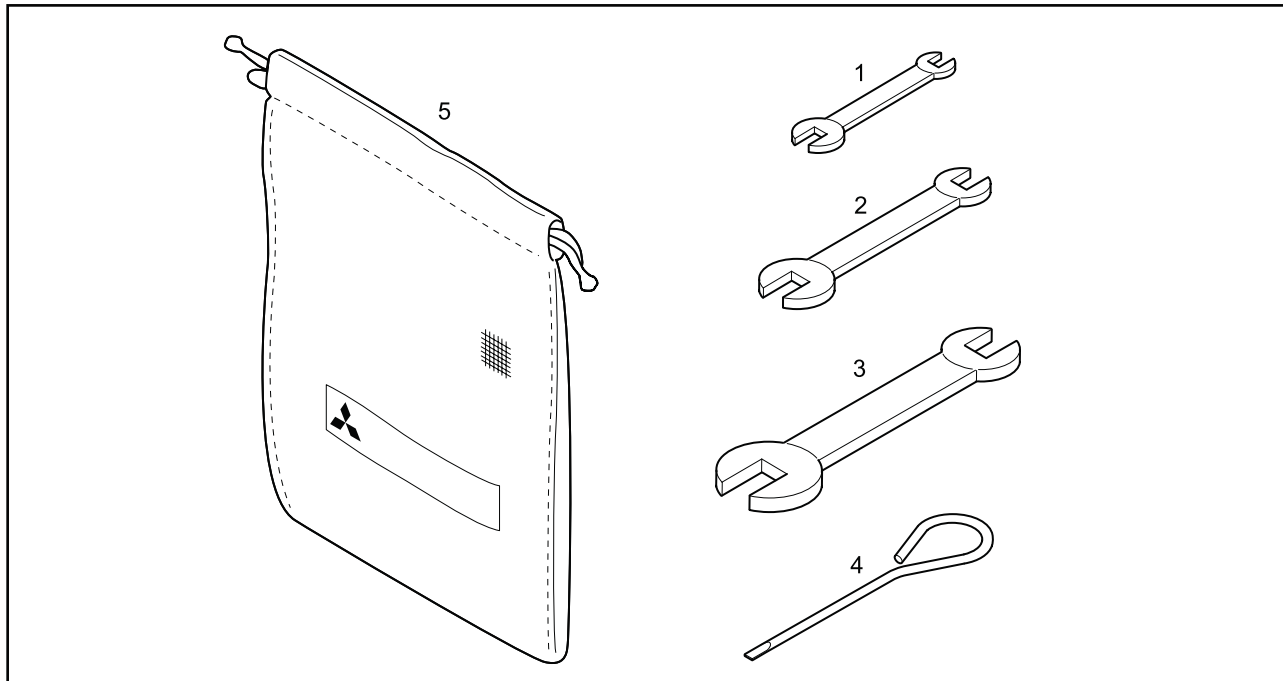
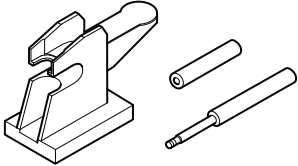
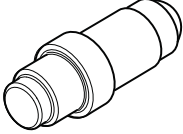
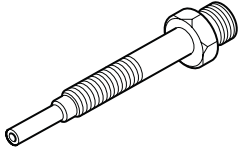
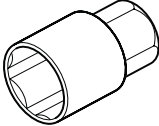
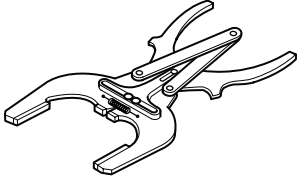

Table 3-1 Basic tools list

No.	Tool name	Use
-	Tool set	Includes 1 to 5
1	Spanner	Width across flats (8 mm × 10 mm) [0.32 × 0.39 in.]
2	Spanner	Width across flats (12 mm × 14 mm) [0.47 × 0.55 in.]
3	Spanner	Width across flats (17 mm × 19 mm) [0.69 × 0.75 in.]
4	Screwdriver	(-)
5	Tool bag	

SERVICE TOOLS

2. Special tools

Tool name	Illustration	Use
Piston pin setting tool		Piston pin removal/installation
Camshaft bushing installer		Punching/press-fitting of front camshaft bushing
Compression gauge adapter		Compression measuring
Oil pressure switch socket wrench (26)		Oil pressure switch removal/installation
Piston ring plier		Piston ring removal/installation

DETERMINATION OF OVERHAUL

- 1. Determining overhaul timing 4-2
- 2. Testing compression pressure 4-3

DETERMINATION OF OVERHAUL

1. Determining overhaul timing

In most cases, the engine should be overhauled when the compression pressure of the engine becomes low. An increase in engine oil consumption and blow-by gas are also considered to evaluate the engine condition. Besides, such symptoms as a decrease in output, increase in fuel consumption, decrease in oil pressure, difficulty of engine starting and increase in noise are also considered for judging the overhaul timing, although those symptoms are often affected by other causes, and are not always effective to judge the overhaul timing. Decreased compression pressure shows a variety of symptoms and engine conditions, thus making it difficult to accurately determine when the engine needs an overhaul. The following shows typical problems caused by reduced compression pressure.

- (1) Decreased output power
- (2) Increased fuel consumption
- (3) Increased engine oil consumption
- (4) Increased blow-by gas through the breather due to worn cylinder liners and piston rings (Visually check the blow-by amount)
- (5) Increased gas leakage due to poor seating of inlet and exhaust valves
- (6) Difficulty in starting
- (7) Increased noise from engine parts
- (8) Abnormal exhaust color after warm-up operation

The engine can exhibit these conditions in various combinations. Some of these problems are directly caused by worn engine parts, while others are not. Phenomena described in items (2) and (6) will result from improper fuel injection volume, fuel injection timing, worn plunger, faulty nozzles and also faulty conditions of electrical devices such as battery and starter. The most valid reason to overhaul an engine is a decrease in compression pressure due to worn cylinder liners and pistons, as described in item (4). In addition to this item, it is reasonable to take other problems into consideration for making the total judgement.

DETERMINATION OF OVERHAUL

2. Testing compression pressure

CAUTION

- (a) Be sure to measure the compression pressure for all the cylinders. It is not a good practice to measure the compression pressure for only one cylinder, and presume the compression for the remaining cylinder.
- (b) Also be sure to check engine speed when measuring the compression pressure, as compression pressure varies with engine speed.
- (c) Measuring the compression pressure at regular intervals is important to obtain correct data.
- (d) When measuring the compression pressure for cylinders one by one, do not remove other fuel injection nozzles from their positions, except for the one being measured.

- (1) Remove the injection nozzle from the cylinder head where the compression pressure is to be measured.
- (2) Remove the glow plugs from all cylinders.
- (3) Attach the compression gauge adapter to the injection nozzle mount, and connect compression gauge.
- (4) Stop the fuel supply.
- (5) Crank the engine with the starter, then read the compression gauge indication while the engine is running at the specified speed.
- (6) If the compression pressure is lower than the limit, overhaul the engine.

Item	Standard	Limit
Engine speed	290 min ⁻¹	-
Compression pressure	2.9 MPa {30 kgf/cm ² } [421 psi]	2.6 MPa {27 kgf/cm ² } [377 psi]
Tolerable difference between cylinders	0.29 MPa {3.0 kgf/cm ² } [42 psi] or less	-

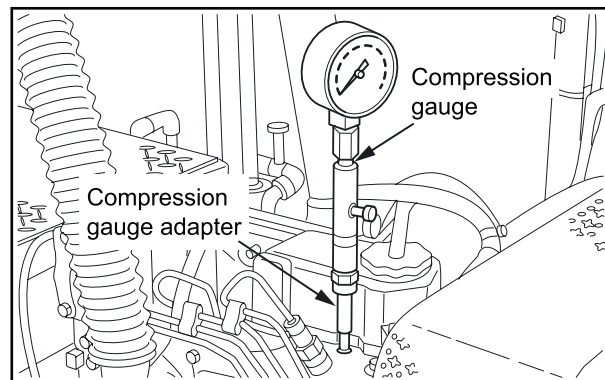

Testing compression pressure

DISASSEMBLY OF BASIC ENGINE

1. Disassembling and inspecting cylinder head and valve mechanism	5-2
1.1 Removing rocker shaft assembly	5-3
1.2 Disassembling rocker shaft assembly	5-3
1.3 Removing cylinder head bolt	5-3
1.4 Removing cylinder head assembly	5-4
1.5 Removing valves and valve spring	5-4
1.6 Removing valve stem seal	5-4
2. Disassembling and inspecting flywheel	5-5
2.1 Removing flywheel	5-6
2.2 Removing flywheel housing	5-6
2.3 Removing rear plate	5-6
2.4 Removing oil seal case	5-7
3. Disassembling and inspecting gear case, timing gear and camshaft	5-8
3.1 Removing tappet	5-9
3.2 Removing crankshaft pulley	5-9
3.3 Removing timing gear case	5-9
3.4 Measuring timing gear backlash	5-10
3.5 Removing idler gear	5-10
3.6 Removing camshaft	5-10
3.7 Removing fuel injection pump camshaft	5-11
3.8 Removing oil pump	5-11
3.9 Removing front plate	5-11
4. Disassembling and inspecting cylinder block, crankshaft, piston and oil pan	5-12
4.1 Removing oil pan	5-13
4.2 Removing oil strainer	5-13
4.3 Removing connecting rod cap	5-13
4.4 Pulling out piston	5-13
4.5 Measuring crankshaft end play	5-14
4.6 Removing main bearing cap	5-14
4.7 Removing crankshaft	5-14
4.8 Removing piston pin	5-15

DISASSEMBLY OF BASIC ENGINE

1. Disassembling and inspecting cylinder head and valve mechanism

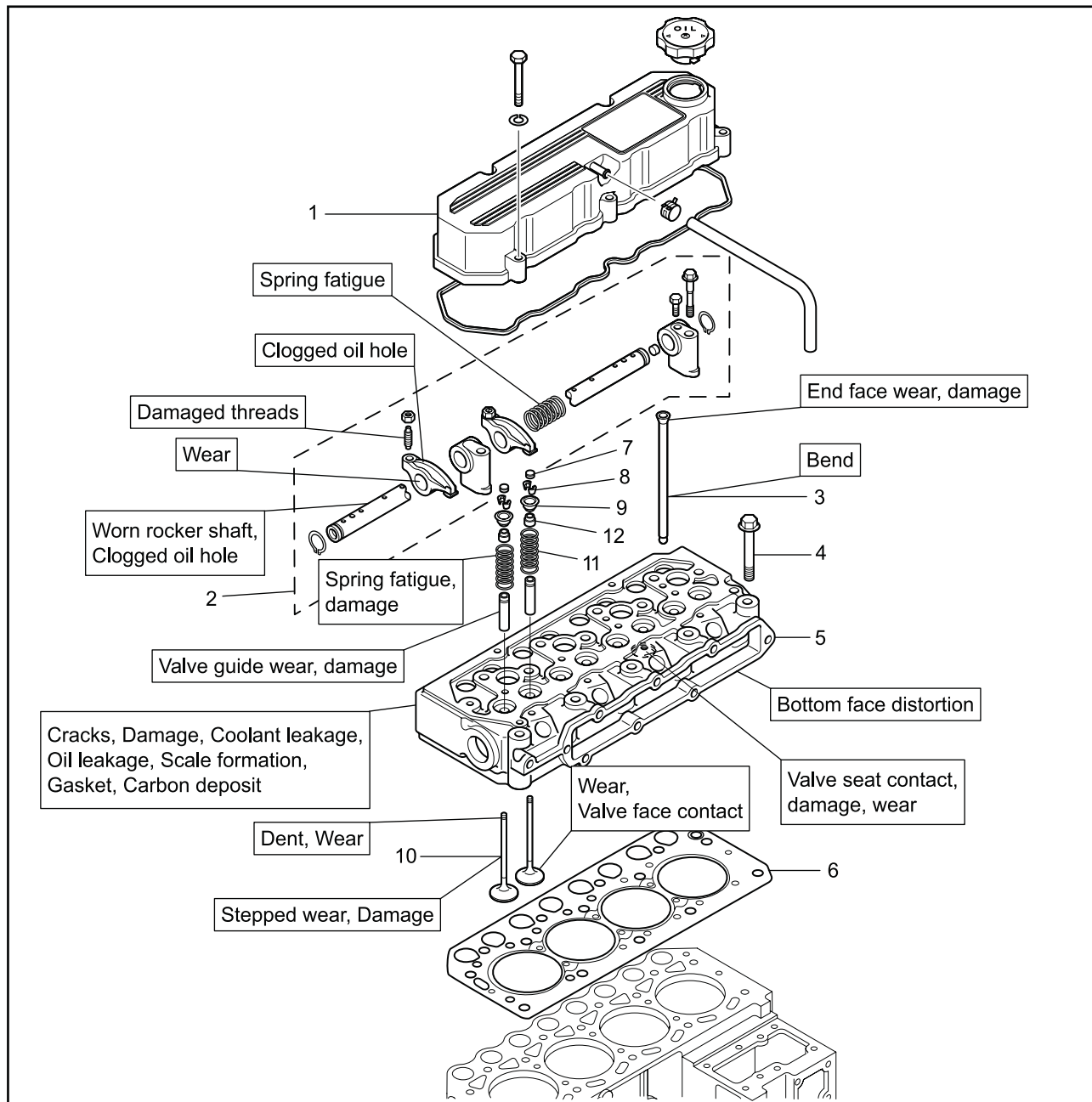

Disassembling and inspecting cylinder head and valve mechanism

Disassembling sequence

- | | | |
|-------------------------|------------------------|--------------------|
| 1 Rocker cover | 5 Cylinder head | 9 Retainer |
| 2 Rocker shaft assembly | 6 Cylinder head gasket | 10 Valve |
| 3 Push rod | 7 Valve cap | 11 Valve spring |
| 4 Cylinder head bolt | 8 Valve lock | 12 Valve stem seal |

DISASSEMBLY OF BASIC ENGINE

1.1 Removing rocker shaft assembly

- (1) Loosen the rocker arm adjusting screw by about one turn.
- (2) Loosen the rocker stay bolts and remove the rocker shaft assembly.

Note: When removing the rocker shaft assembly, remove it together with the rocker stay bolts, and keep them together for reassembling.

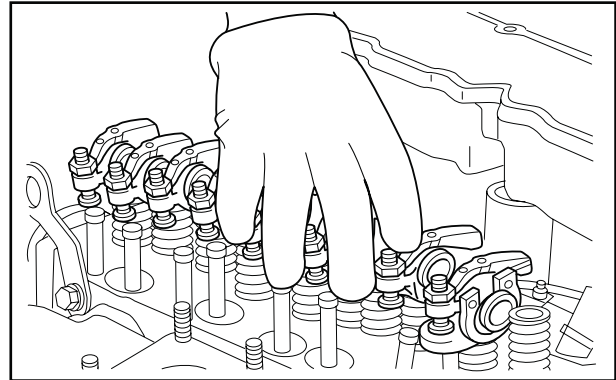

Removing rocker shaft assembly

1.2 Disassembling rocker shaft assembly

Disassemble the rocker shaft assembly.

Note: Be sure to arrange the parts in order during disassembly. Keep the original combination of rocker arm and shaft assembly, and when reassembling, make sure to install them in their original positions to restore the same clearance between the rocker shaft and arms.

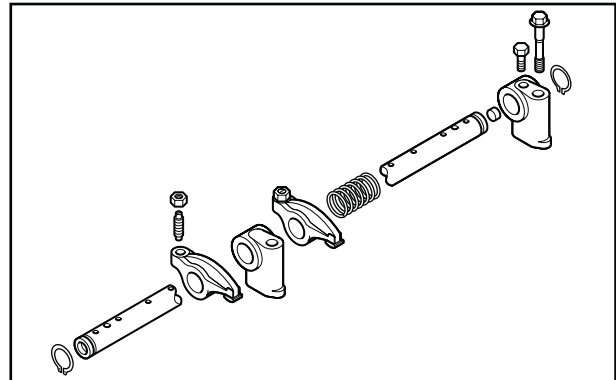

Disassembling rocker shaft assembly

1.3 Removing cylinder head bolt

Loosen cylinder head bolts in the numerical order as shown in the illustration.

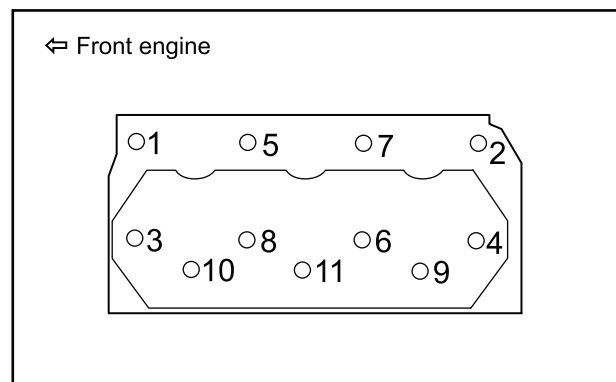

Tightening order for cylinder head bolt

DISASSEMBLY OF BASIC ENGINE

1.4 Removing cylinder head assembly

CAUTION

When removing the cylinder head gasket, be careful not to damage the cylinder head or crankcase surface by tools such as a screwdriver.

- (1) Remove the cylinder head bolt.
- (2) Remove the cylinder head assembly by lifting it up.

Note: If the cylinder head assembly cannot be removed due to crimping of the cylinder head gasket, tap the thick area on the side of the cylinder head using a plastic hammer to give a shock.

- (3) Remove the gasket from the cylinder head.

Note: If there is a cylinder head problem, check the bolts for tightness with a torque wrench before removing the cylinder head bolts.

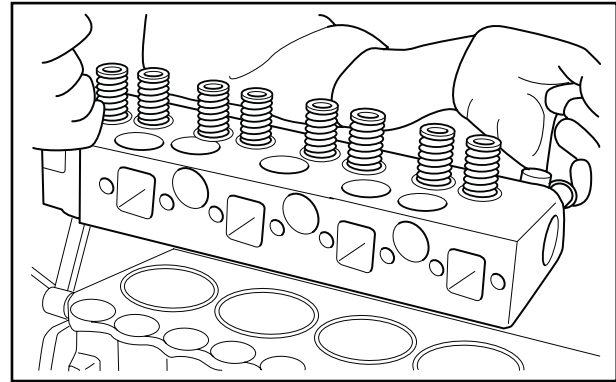

Removing cylinder head assembly

1.5 Removing valves and valve spring

- (1) Use a valve lifter to compress the valve spring and remove the valve lock.
- (2) Remove the retainer, valve spring and valve.

Note: Put match marks for easy identification of the installing position if the valve is to be reused. When reassembling, do not change the combination of the valve and valve seat.

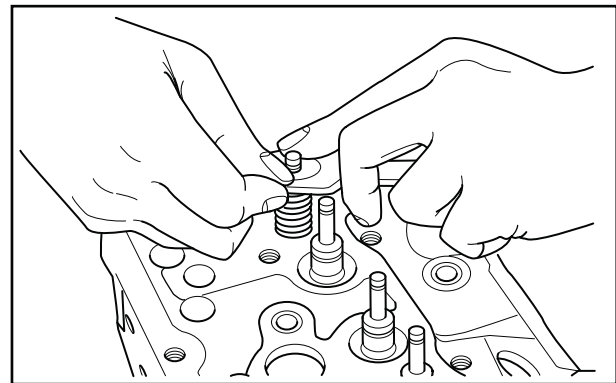

Removing valve and valve spring

1.6 Removing valve stem seal

Grab the stem seal with pliers and remove.

Note: Be sure to replace the stem seal with the new one when reassembling the valve and valve spring.

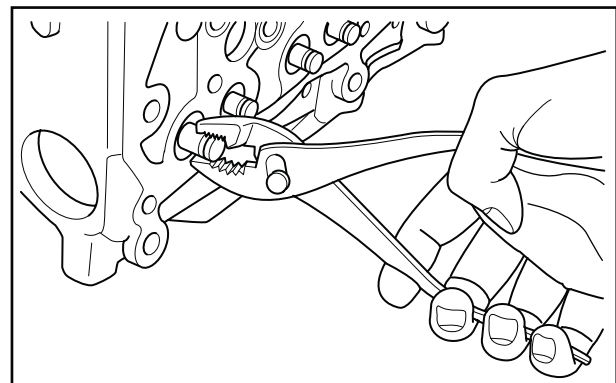

Removing valve stem seal

DISASSEMBLY OF BASIC ENGINE

2. Disassembling and inspecting flywheel

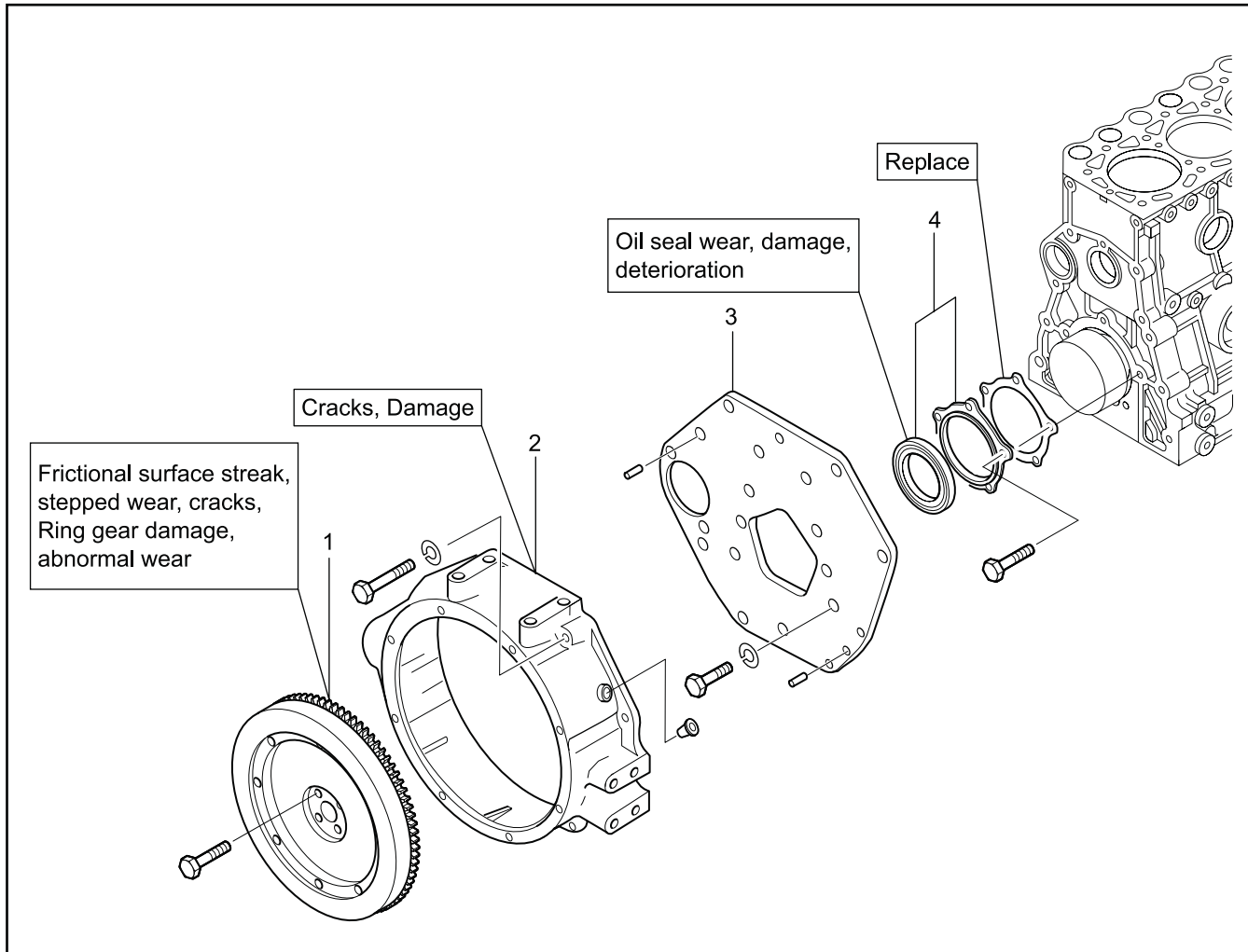

Disassembling and inspecting flywheel

Disassembling sequence

- | | |
|--------------------|---------------------------|
| 1 Flywheel | 3 Rear plate |
| 2 Flywheel housing | 4 Oil seal case, oil seal |

DISASSEMBLY OF BASIC ENGINE

2.1 Removing flywheel

CAUTION

- (a) Be careful not to cut yourself with the ring gear when pulling out the flywheel.
Be careful not to drop or hit the flywheel when removing.
- (b) The personnel who holds the pulley must pay due attention to safety.
Also, personnel must stay in close contact with each other during work.

- (1) One personnel must firmly hold the pulley with a wrench to prevent the flywheel from turning.
- (2) Remove one bolt from the flywheel.
- (3) Screw a guide bolt into the threaded hole of the bolt that has been removed.
- (4) Remove remaining bolts from the flywheel.
- (5) Hold the flywheel firmly with both hands, and by moving it back and forth, pull it out straight.

Note: The ring gear is shrink fitted to the flywheel. Do not remove the ring gear unless it is defective.

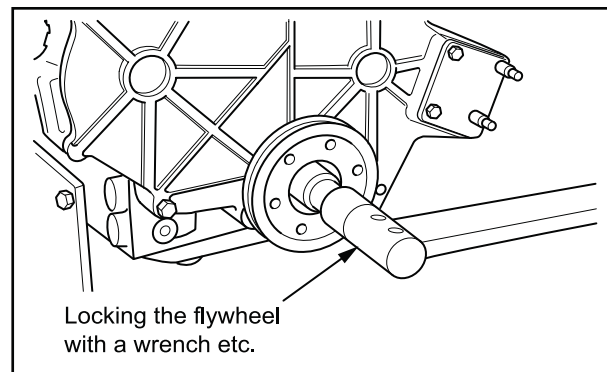

Locking the flywheel

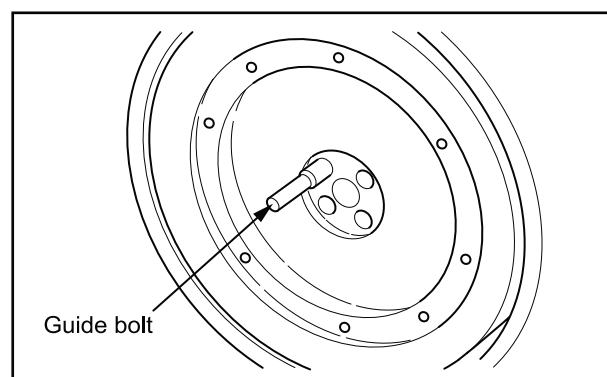

Removing flywheel

2.2 Removing flywheel housing

CAUTION

Be careful not to damage the oil seal.

- (1) Remove bolts from the flywheel housing.
- (2) Remove the flywheel housing.

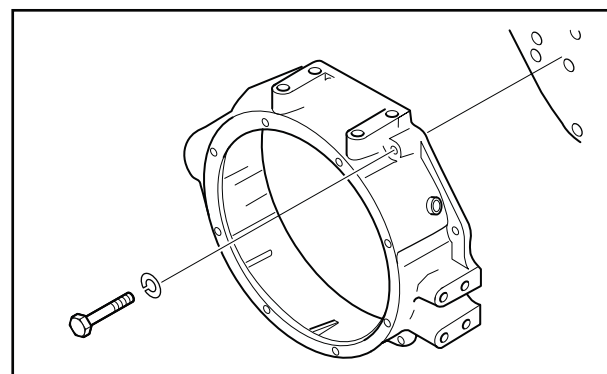

Removing flywheel housing

2.3 Removing rear plate

Remove the rear plate mounting bolt, and remove the rear plate.

Note: When removing the rear plate, firmly hold the rear plate with both hands and pull the rear plate straight out by moving it back and forth, as the rear plate is positioned by knock bushing.

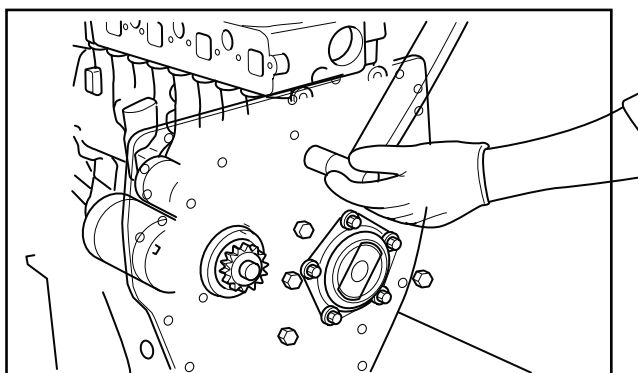

Removing rear plate

DISASSEMBLY OF BASIC ENGINE

2.4 Removing oil seal case

CAUTION

Be very careful not to damage the oil seal.

- (1) Remove bolts from the oil seal case.
- (2) Pry out the oil seal case from the cylinder block using a screwdriver.

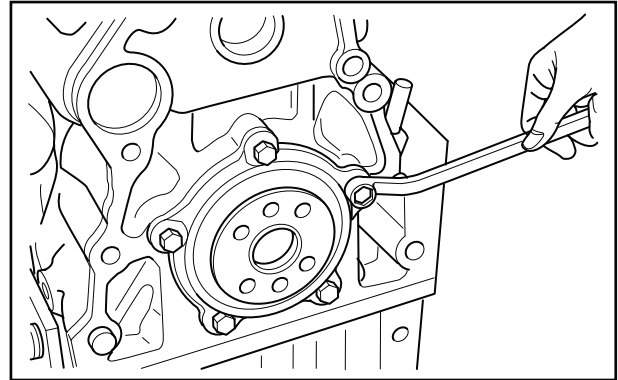

Removing oil seal case

DISASSEMBLY OF BASIC ENGINE

3. Disassembling and inspecting gear case, timing gear and camshaft

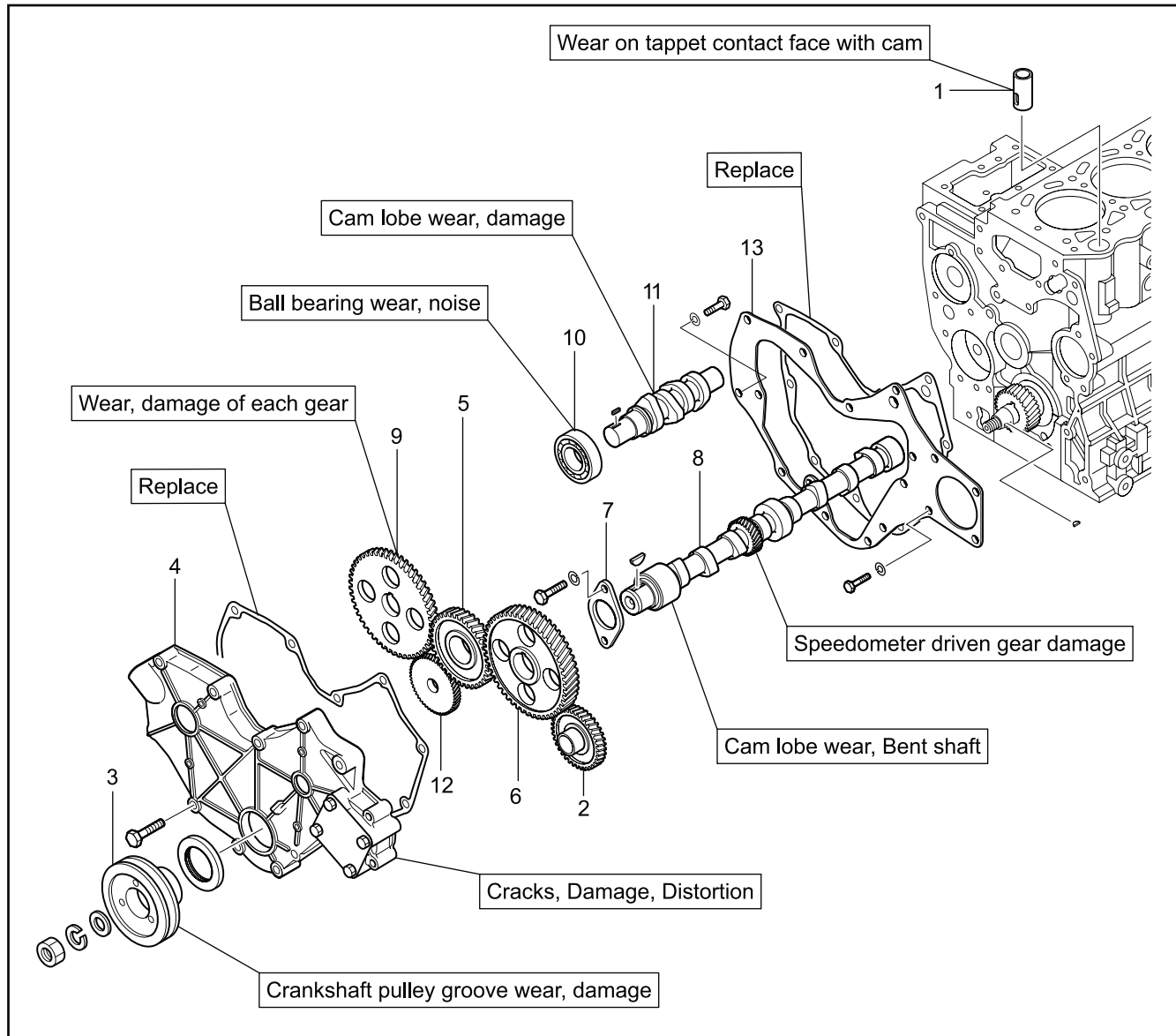

Disassembling and inspecting gear case, timing gear and camshaft

Disassembling sequence

- | | | |
|---------------------|---|---|
| 1 Tappet | 7 Thrust plate | 11 Fuel injection pump camshaft
(Remove parts 9 to 11 as a unit) |
| 2 PTO gear | 8 Camshaft
(Remove parts 6 to 8 as a unit) | 12 Oil pump |
| 3 Crankshaft pulley | 9 Fuel injection
pump camshaft gear | 13 Front plate |
| 4 Timing gear case | 10 Ball bearing | |
| 5 Idler gear | | |
| 6 Camshaft gear | | |

DISASSEMBLY OF BASIC ENGINE

3.1 Removing tappet

Remove the tappet from the cylinder block using the push rods.

Note: If the camshaft is removed before the tappet, the tappet will fall in the oil pan.

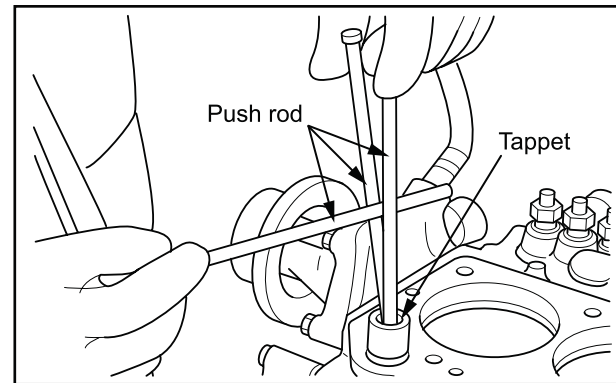

Removing tappet

3.2 Removing crankshaft pulley

CAUTION

The bar that stops the the crankshaft from turning may come off. Pay due attention to safety.

- (1) Screw two guide bolts into the threaded holes at the rear end of the crankshaft. Stick a bar across the guide bolts to prevent the crankshaft from turning.
- (2) Remove the crankshaft pulley.
- (3) Take out the woodruff key of the crankshaft.

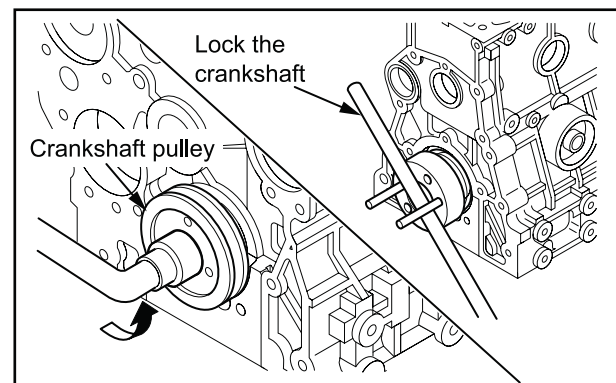

Removing crankshaft pulley

3.3 Removing timing gear case

CAUTION

The front plate is bolted to the crankcase from inside the gear case. Do not attempt to remove the front plate together with the gear case by tapping.

- (1) Remove bolts from the timing gear case.
- (2) Remove the timing gear case.

Note: Bolts have different lengths. Pay attention to the positions of bolts to ensure correct reassembling.

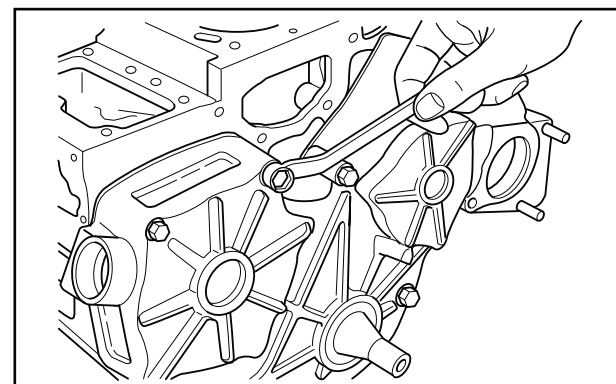

Removing timing gear case

DISASSEMBLY OF BASIC ENGINE

3.4 Measuring timing gear backlash

Measure the backlash of the timing gears by using one of the following two methods; measure the gear play with the dial gauge plunger applied to a tooth flank on the pitch circle at a right angle to the tooth axis, or measure the clearance between gears by inserting a feeler gauge between the gears at the tooth-to-tooth contacting area. Replace the faulty gear pair if the limit is exceeded.

	Item	Standard	Limit
Timing gear backlash	Between crankshaft gear and idler gear	0.04 to 0.12 mm [0.0016 to 0.0047 in.]	0.30 mm [0.0118 in.]
	Between idler gear and valve camshaft gear		
	Between idler gear and pump camshaft gear		
	Between valve camshaft gear and PTO gear	0.08 to 0.19 mm [0.0031 to 0.0075 in.]	
	Between pump camshaft gear and oil pump gear	0.07 to 0.20 mm [0.0028 to 0.0079 in.]	

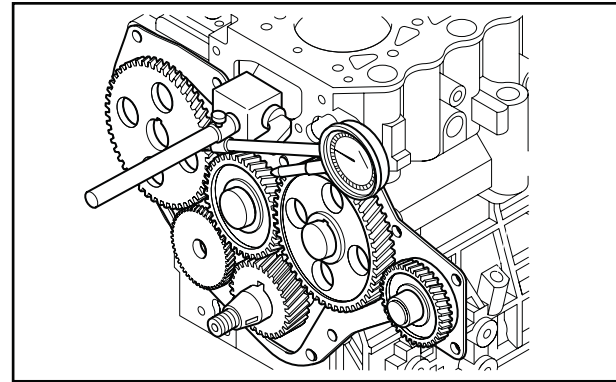

Measuring backlash timing gear

3.5 Removing idler gear

Remove the idler gear while turning the gear.

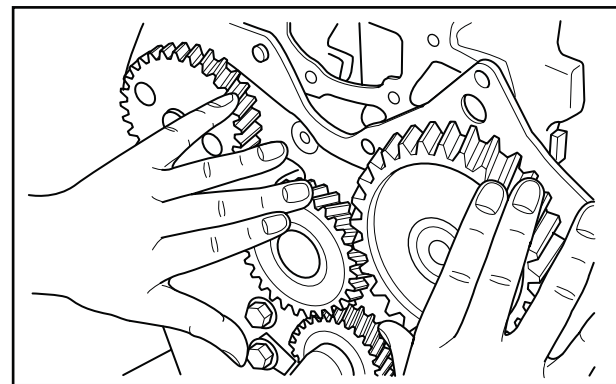

Removing idler gear

3.6 Removing camshaft

CAUTION

Be careful not to damage the camshaft cam, the camshaft journal, and the cam hole of the cylinder block.

- (1) Rotate the camshaft to see the thrust plate bolt through the camshaft gear hole.
- (2) By using the socket, remove the thrust plate bolt.
- (3) Remove the camshaft from the cylinder block

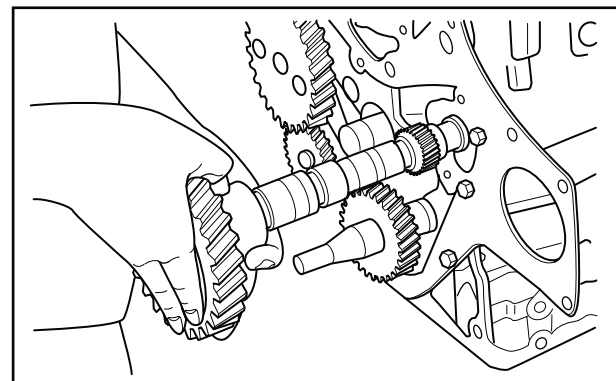

Removing camshaft

DISASSEMBLY OF BASIC ENGINE

3.7 Removing fuel injection pump camshaft

CAUTION

When pulling out the fuel injection pump camshaft, be careful not to cause damage to the cam portion of the fuel injection pump camshaft and the cam hole of the cylinder block.

- (1) Remove the stopper bolt.
- (2) Hit the rear part of the fuel injection pump camshaft with a copper rod. Pull out the fuel injection pump camshaft to the front side.

Note: Use hydraulic press to separate the camshaft gear and fuel injection pump camshaft gear from the shaft. Perform separating the gears as necessary.

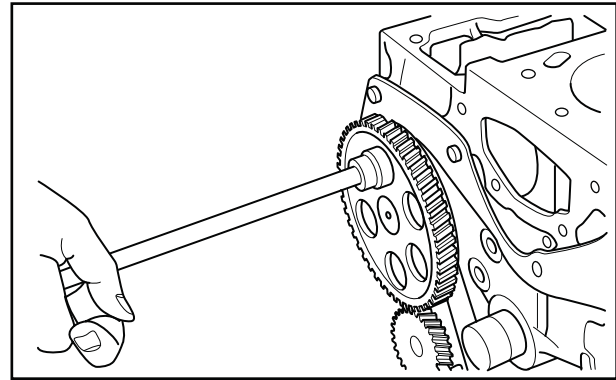

Removing pump camshaft stopper bolt

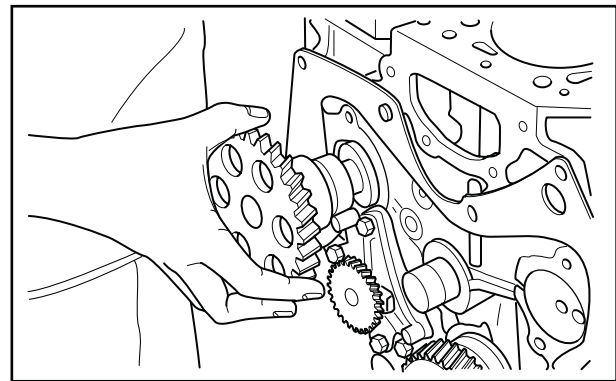

Removing pump shaft

3.8 Removing oil pump

Remove the oil pump mounting bolt, and remove the oil pump from the cylinder block.

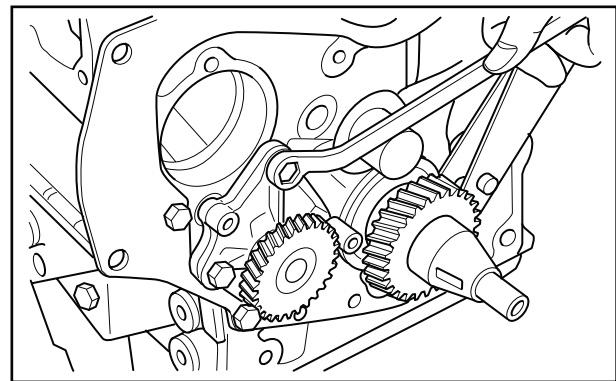

Removing oil pump

3.9 Removing front plate

- (1) Remove the front plate bolts.
- (2) Remove the front plate from the crankcase.

Note: If it is difficult to remove the front plate, lightly tap it with a plastic hammer.

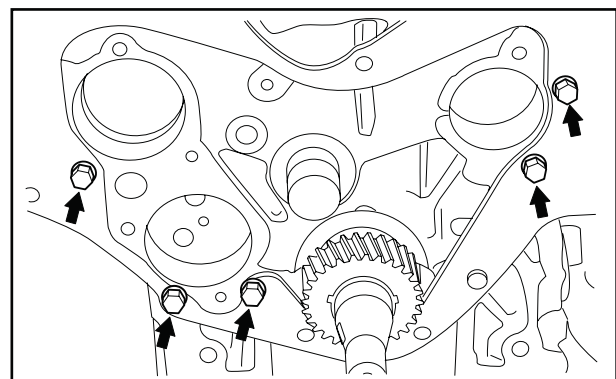

Front plate mounting bolt

DISASSEMBLY OF BASIC ENGINE

4. Disassembling and inspecting cylinder block, crankshaft, piston and oil pan

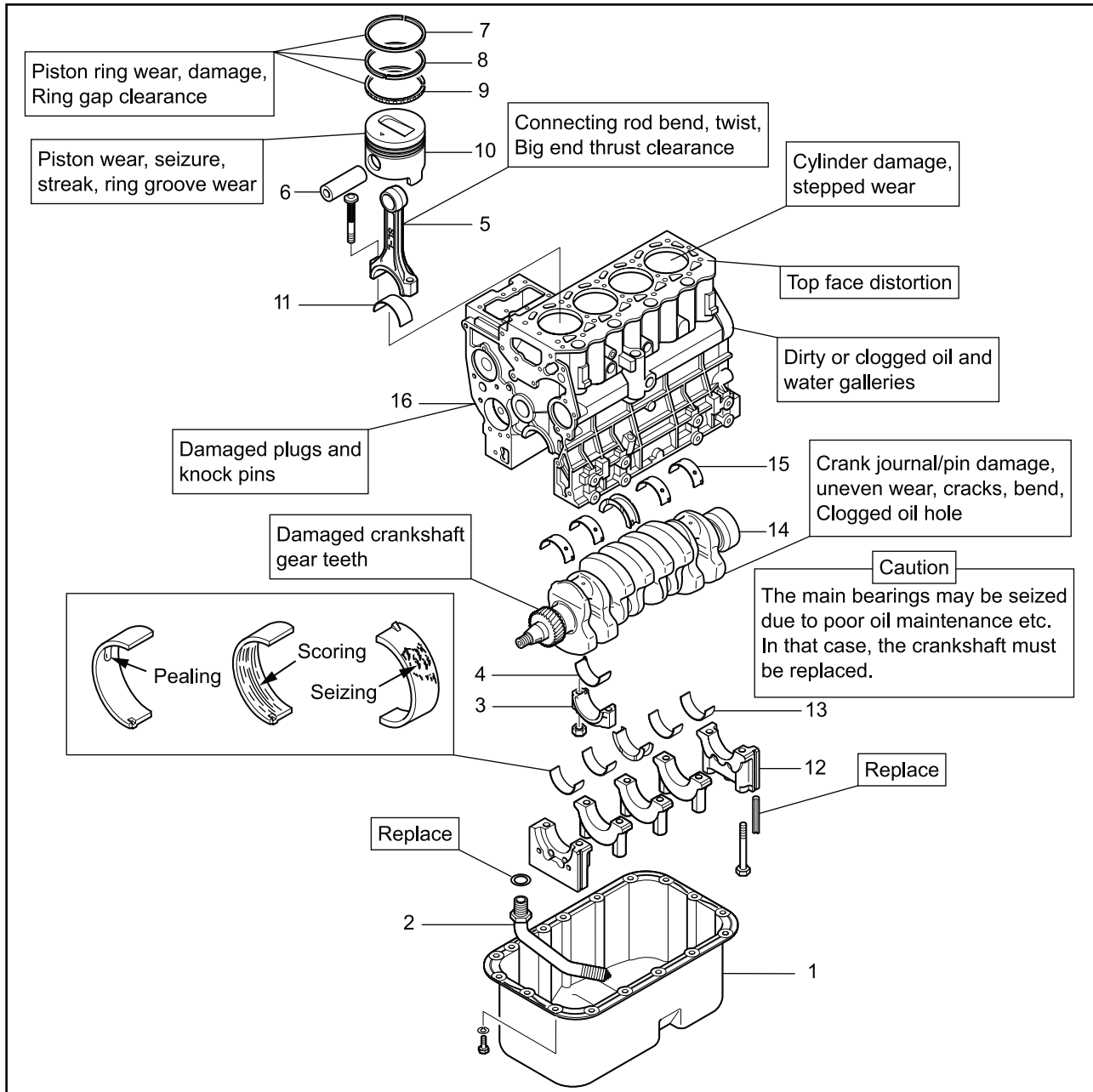

Disassembling and inspecting cylinder block, crankshaft, piston and oil pan

Disassembling sequence

- | | | |
|--------------------------------|---|-----------------------|
| 1 Oil pan | 7 No.1 compression | 12 Main bearing cap |
| 2 Oil screen | 8 No.2 compression | 13 Lower main bearing |
| 3 Connecting rod cap | 9 Oil ring | 14 Crankshaft |
| 4 Lower connecting rod bearing | 10 Piston
(Remove parts 5 to 10 as a unit) | 15 Upper main bearing |
| 5 Connecting rod | 11 Upper connecting rod bearing | 16 Cylinder block |
| 6 Piston pin | | |

Note: When replacing the cylinder block, carefully remove parts (relief valve, etc.) mounted on the non-reusable cylinder block so that they can be reused.

DISASSEMBLY OF BASIC ENGINE

4.1 Removing oil pan

CAUTION

Do not insert a chisel or screwdriver between the oil pan and crankcase to remove the oil pan, as it could deform the oil pan flange.

- (1) Turn the engine around.
- (2) Remove bolts from the oil pan.
- (3) To remove oil pan, tap bottom corners of the oil pan with a plastic hammer.

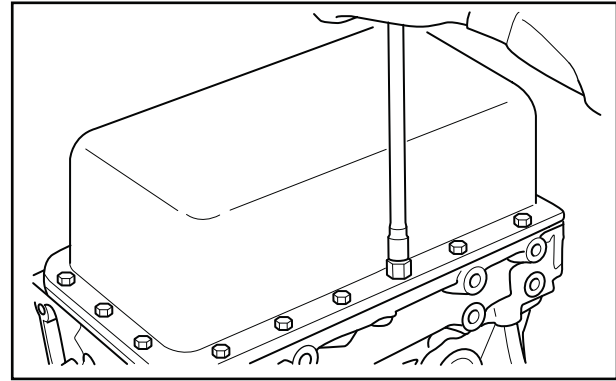

Removing oil pan

4.2 Removing oil strainer

Loosen the nut, and remove the oil strainer.

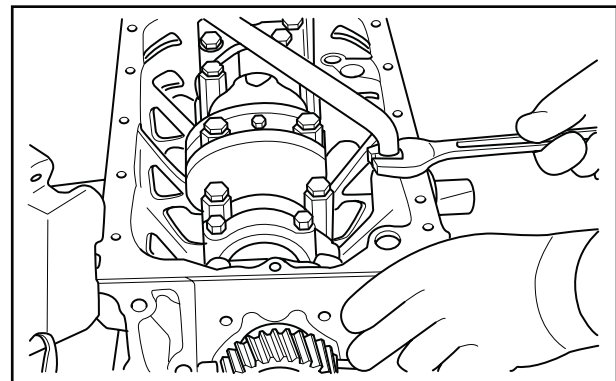

Removing oil strainer

4.3 Removing connecting rod cap

- (1) Lay the engine by its side.
- (2) Mark the cylinder number on the connecting rod and connecting rod cap so that their combination is not changed when reassembling.
- (3) Remove the connecting rod caps.

Note: Mark the cylinder No. and upper/lower on connecting rod bearings to ensure correct reassembling.

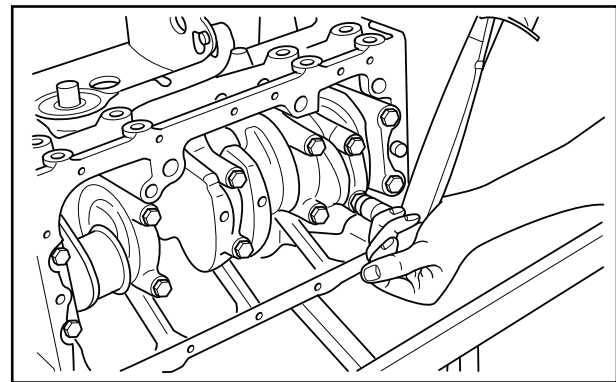

Removing connecting rod cap

4.4 Pulling out piston

- (1) Turn the crankshaft to bring the piston to the top dead center.
- (2) Using a piece of wood such a hammer handle, push the mating surface of the connecting rod cap, and pull the piston and connecting rod upward from the cylinder.

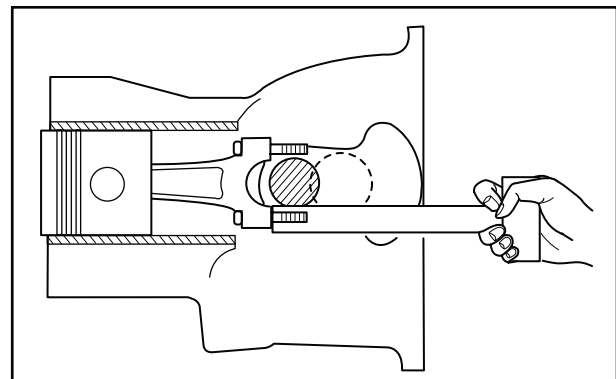

Removing piston

DISASSEMBLY OF BASIC ENGINE

4.5 Measuring crankshaft end play

- (1) With attach the dial gauge to top of the crankshaft, measure the end play.
- (2) If measured value exceeds the limit, replace the flange bearing with new one.

Item	Standard	Limit
Crankshaft end play	0.050 to 0.175 mm [0.0020 to 0.0069 in.]	0.500 mm [0.0197 in.]

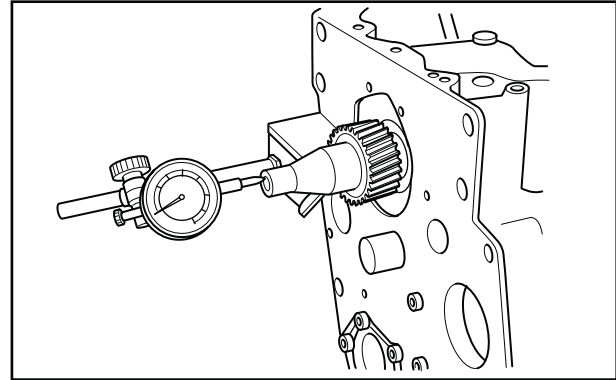

Measuring crankshaft end play

4.6 Removing main bearing cap

- (1) Reverse the engine.
- (2) Remove the main bearing cap bolt.
- (3) Remove the main bearing cap together with the lower main bearing.

Use a sliding hammer to remove main bearing caps on the front and rear ends.

Note: (a) Be careful not to damage main bearings.

(b) Mark each main bearing for its cylinder number.

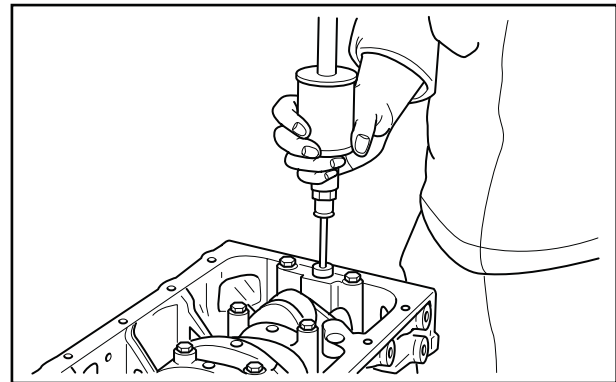

Removing main bearing cap

4.7 Removing crankshaft

CAUTION

Be careful not to damage bearings when removing the crankshaft.

- (1) Slowly lift the crankshaft straight up.
- (2) Arrange the bearings in the order of disassembly so that their original positions are restored when reassembling.

Note: (a) When raising the crankshaft, do not allow wire chain to come into contact with the crankshaft.

To avoid damage to the crankshaft when raising, use a cloth belt or pad.

(b) Mark the bearings for their cylinder numbers.

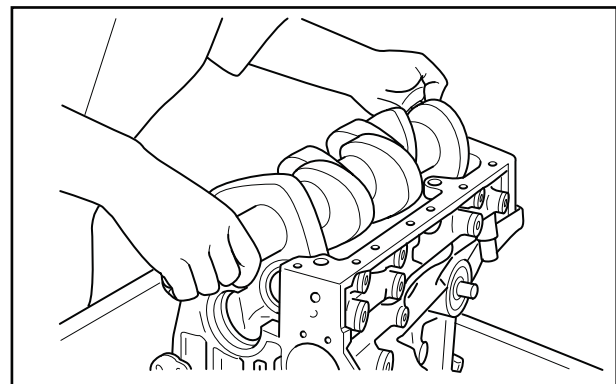

Removing crankshaft

DISASSEMBLY OF BASIC ENGINE

4.8 Removing piston pin

CAUTION

Do not try to remove the piston pin by tapping.

If the piston pin has been agglutinated and requires a great force to remove, replace piston pin and / or connecting rod with a new one after removing.

Removing the piston pin using a piston pin setting tool.

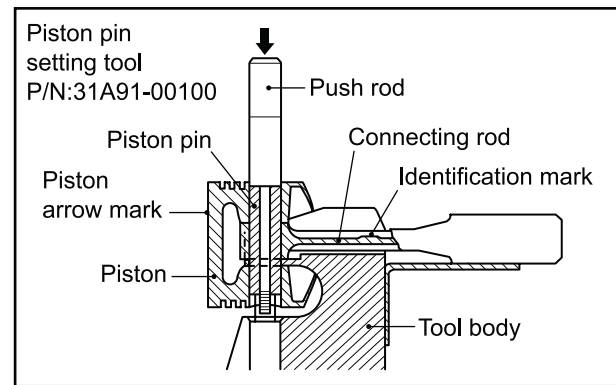

Removing piston pin(1)

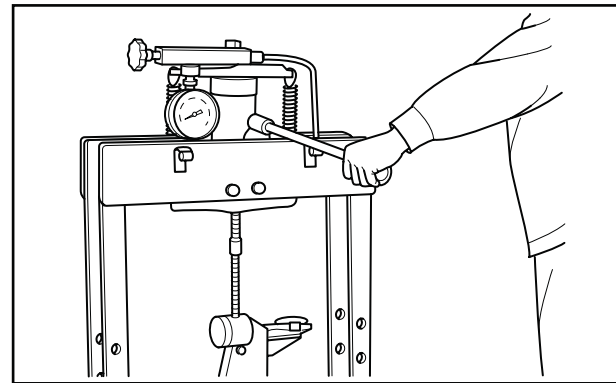

Removing piston pin(2)

INSPECTION AND REPAIR OF BASIC ENGINE

1. Inspecting and repairing cylinder head and valve mechanism	6-2
1.1 Measuring distortion of the bottom surface of the cylinder head	6-2
1.2 Measuring clearance between rocker arm and rocker shaft	6-2
1.3 Measuring perpendicularity and free length of valve spring	6-2
1.4 Measuring push rod runout	6-3
1.5 Measuring valve stem outside diameter and valve guide inside diameter	6-3
1.6 Replacing valve guide	6-3
1.7 Inspecting valve face	6-4
1.8 Refacing valve face	6-4
1.9 Refacing valve seat	6-5
1.10 Lapping valve and valve seat	6-5
1.11 Removing combustion jet	6-6
2. Inspecting and repairing flywheel	6-7
2.1 Measuring flatness of flywheel	6-7
2.2 Inspecting ring gear	6-7
2.3 Replacing ring gear	6-7
2.3.1 Removing ring gear	6-7
2.3.2 Installing ring gear	6-7
3. Inspecting and repairing gear case, timing gear and camshaft	6-8
3.1 Measuring timing gear backlash	6-8
3.2 Measuring clearance between idler gear and idler shaft	6-8
3.3 Replacing idler shaft	6-8
3.4 Measuring clearance between camshaft journal and bushing	6-9
3.5 Replacing camshaft bushing	6-9
3.5.1 Removing camshaft bushing	6-9
3.5.2 Driving in camshaft bushing	6-9
3.6 Measuring cam lift	6-10
3.7 Measuring cam height of fuel injection pump camshaft	6-10
3.8 Inspecting tappet	6-10
3.9 Measuring clearance between tappet and tappet guide hole	6-10
4. Inspecting and repairing cylinder block, crankshaft and piston	6-11
4.1 Measuring cylinder inside diameter	6-11
4.2 Measuring piston outside diameter	6-11
4.3 Measuring piston ring groove	6-12
4.4 Measuring piston ring end gap	6-12
4.5 Measuring piston pin bore diameter and piston pin outside diameter	6-13
4.6 Inspecting connecting rod bend and twist	6-13
4.7 Measuring connecting rod end play	6-14
4.8 Measuring clearance between connecting rod bearing and crankpin	6-15
4.9 Measuring clearance between main bearing and crankshaft journal	6-16
4.10 Measuring crankshaft runout	6-17
4.11 Replacing crankshaft gear	6-17
4.11.1 Removing crankshaft gear	6-17
4.11.2 Installing crankshaft gear	6-17
4.12 Measuring distortion cylinder block top surface	6-18

1. Inspecting and repairing cylinder head and valve mechanism

1.1 Measuring distortion of the bottom surface of the cylinder head

CAUTION

Refacing of cylinder head should be kept to an absolute minimum.

Excessive grinding of the cylinder head may result in defects such as defective combustion and stamping (contact between piston and valve).

With a straight edge placed on the bottom face of the cylinder head, measure the bottom face distortion using a feeler gauge. If the measurement exceeds the limit, grind the bottom face using a surface grinder.

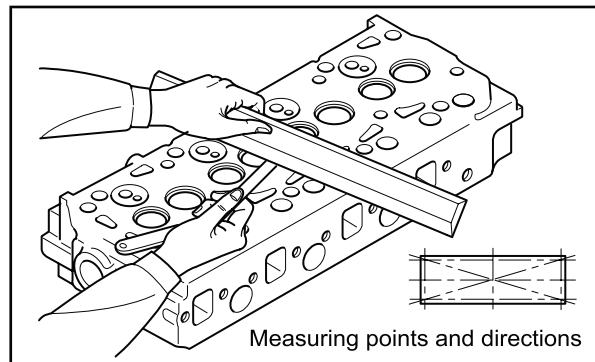

Measuring distortion cylinder head bottom face

Item	Standard	Limit
Bottom surface distortion	0.05 mm [0.0020 in.] or less	0.10 mm [0.0039 in.]

1.2 Measuring clearance between rocker arm and rocker shaft

Measure the inside diameter of the rocker arm and outside diameter of the rocker shaft.

Replace the rocker arm or rocker shaft if the clearance exceeds the limit.

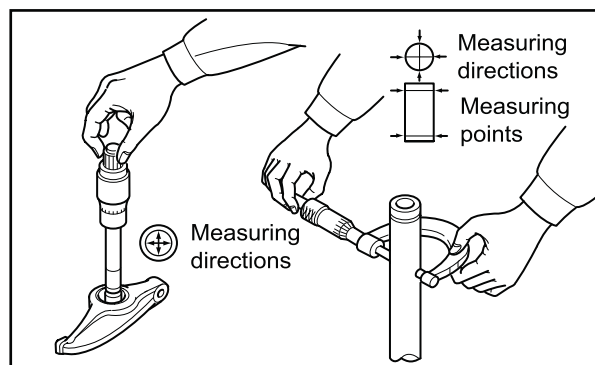

Measuring clearance between rocker arm and rocker shaft

Item	Nominal	Standard	Limit
Rocker arm inside diameter	ø 18.9 mm [0.744 in.]	18.910 to 18.930 mm [0.7445 to 0.7453 in.]	-
Rocker shaft diameter	ø 18.9 mm [0.744 in.]	18.880 to 18.898 mm [0.7433 to 0.7440 in.]	-
Clearance between rocker arm and shaft	-	0.012 to 0.050 mm [0.0005 to 0.0020 in.]	0.200 mm [0.0079 in.]

1.3 Measuring perpendicularity and free length of valve spring

Measure the perpendicularity and free length of the valve spring. If the limit is exceeded, replace the valve spring with a new one.

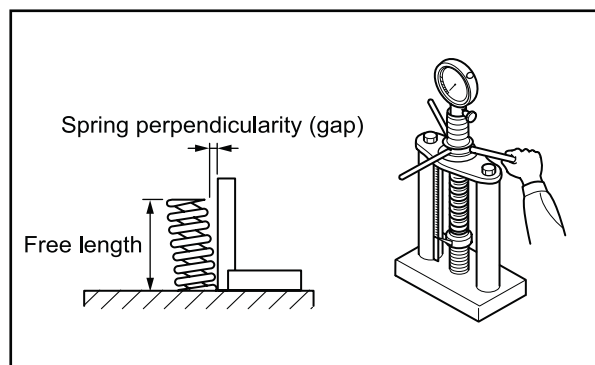

Measuring perpendicularity and free length of valve spring

Item	Standard		Limit
Free length	47 mm [1.85 in.]		46 mm [1.81 in.]
Squareness	 $\theta = 2.0^\circ$ or less $\Delta = 0.2$ [0.0079] or less $L_f = 47$ mm [1.85 in.]		$\Delta = 0.5$ mm [0.020 in.] over entire length
Rest length /load	39.0 mm [1.535 in.]/ 131 to 145 N {13.3 to 14.7 kgf} [29 to 32 lbf]	30.1 mm [1.185 in.]/ 279 to 309 N {28.5 to 31.5 kgf} [63 to 69 lbf]	-15%

INSPECTION AND REPAIR OF BASIC ENGINE

1.4 Measuring push rod runout

Measure the runout of push rod. If the standard value is exceeded, replace the push rod.

Item	Standard	Remark
Push rod runout	0.3 mm [0.012 in.] or less	Total indicated reading (TIR)

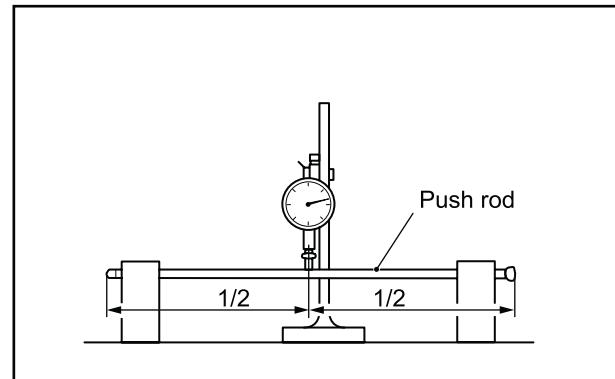

Measuring push rod runout

1.5 Measuring valve stem outside diameter and valve guide inside diameter

Measure the diameter at the top and bottom ends at right angles to the outer and inner surfaces, since valve stems and valve guides are more likely to wear at both ends. If the outside diameter is less than the limit, or the clearance exceeds the limit, replace either the valve or the valve guide with a new one.

Item	Nominal	Standard	Limit	
Valve stem outside diameter	Inlet	ø 6.6 mm [0.260 in.]	6.565 to 6.580 mm [0.2585 to 0.2591 in.]	6.500 mm [0.2559 in.]
	Exhaust	ø 6.6 mm [0.260 in.]	6.530 to 6.550 mm [0.2571 to 0.2579 in.]	6.500 mm [0.2559 in.]
Clearance between valve stem and valve guide	Inlet	-	0.020 to 0.050 mm [0.0008 to 0.0020 in.]	0.100 mm [0.0039 in.]
	Exhaust	-	0.050 to 0.085 mm [0.0020 to 0.0033 in.]	0.150 mm [0.0059 in.]
Valve guide mounting dimension	10 mm [0.39 in.]	9.5 to 10.5 mm [0.374 to 0.413 in.]	-	

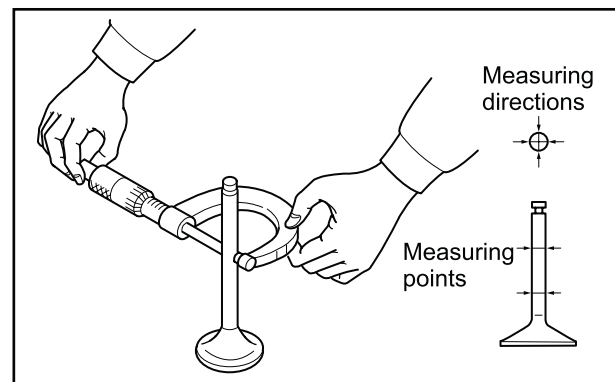

Measuring valve stem outside diameter

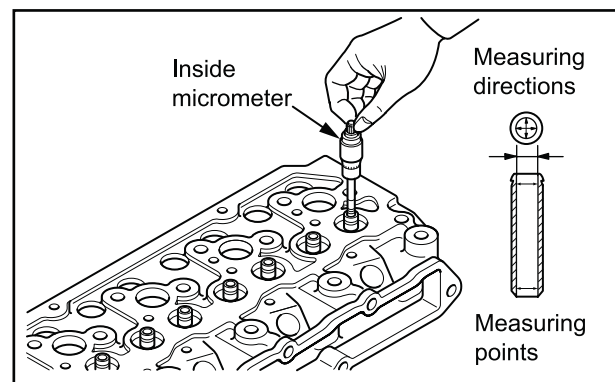

Measuring valve guide inside diameter

1.6 Replacing valve guide

- (1) Remove the valve guide with a punching tool pressing from the cylinder head bottom surface.
- (2) When press-fitting the new valve guide, press-fit the valve guide with a press from the cylinder head top surface.
- (3) After press-fitting the valve guide, insert the valve and check the movement.
- (4) When replacing the valve with new one, check the contact between the valve and the valve seat.

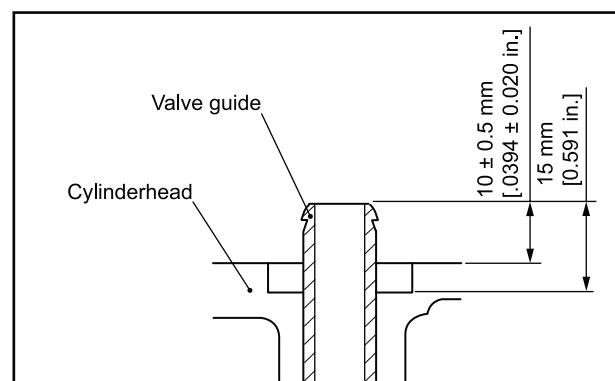

Replacing valve guide

INSPECTION AND REPAIR OF BASIC ENGINE

1.7 Inspecting valve face

Apply a thin coat of Shinmyoutan or equivalent lead-free coloring paste on the valve face, and strike the valve face against the valve seat using a valve lapper to check for contact condition. If the contact is not even, or any defects are found, or if the limit is exceeded, reface or replace the valve.

Note: (a) Inspect the valve face after the valve guide is repaired or replaced.

(b) Do not rotate the valve when pressing the valve face coated with Shinmyoutan or equivalent lead-free dye against the valve seat.

(c) Always lap the valve and valve seat after the valve has been refaced or replaced.

Item	Nominal	Standard	Limit	
Valve seat	Valve seat angle	45°	-	
	Valve sinkage	0 mm [0.00 in.]	0.25 to 0.75 mm [0.0098 to 0.0295 in.]	1.50 mm [0.0591 in.]
	Seat width	1.6 mm [0.063 in.]	1.30 to 1.80 mm [0.0512 to 0.0709 in.]	2.50 mm [0.0984 in.]
Valve margin	1.5 mm [0.059 in.]	1.35 to 1.65 mm [0.0531 to 0.0650 in.]	0.50 mm [0.0197 in.]	

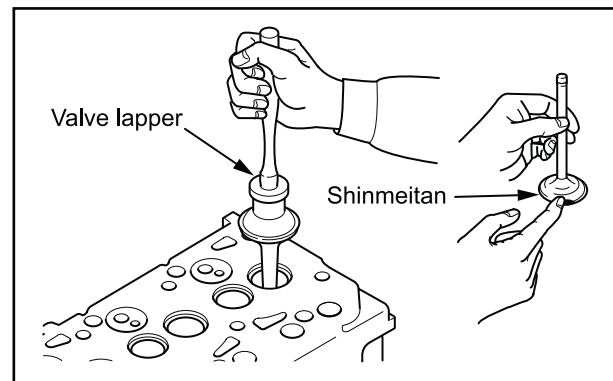

Refacing valve face

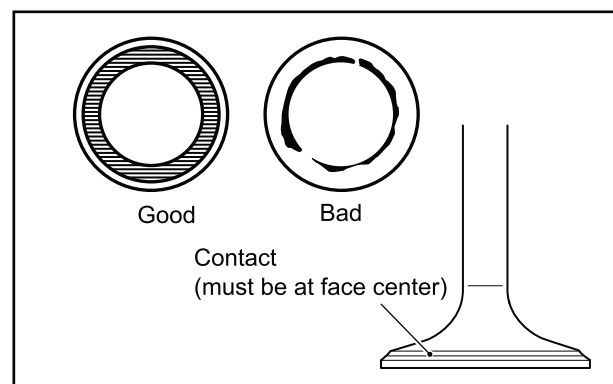

Contact between valve seat and valve

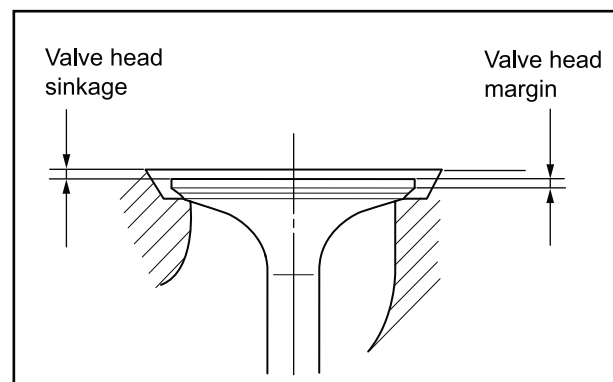

Valve sinkage

1.8 Refacing valve face

If the valve face is significantly worn out, reface the valve face using a valve refacer.

Note: (a) Grind the valve face using the valve refacer at the specified angle.

(b) Secure the valve margin width equal to or greater than the limit. If the dimensions after refacing does not meet the specified values, replace the valve with a new one.

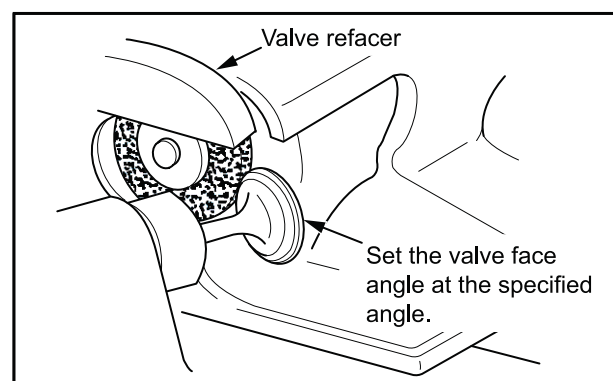

Refacing valve face

INSPECTION AND REPAIR OF BASIC ENGINE

1.9 Refacing valve seat

- (1) Use the valve seat cutter or valve seat grinder to reface the valve seat. After refacing, sand the valve seat lightly using 400 grit sandpaper, inserting it between the cutter and valve seat.
- (2) Lap the valve in the valve seat.

Note: (a) Valve seat refacing should be kept to an absolute minimum.

- (b) If the valve seat width exceeds the limit due to wear or refacing, replace the valve seat with a new one.
- (c) If the valve sinkage exceeds the limit after refacing, replace the valve seat with a new one.

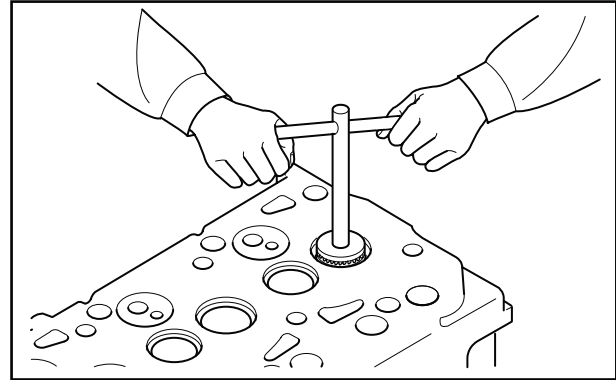

Refacing valve seat

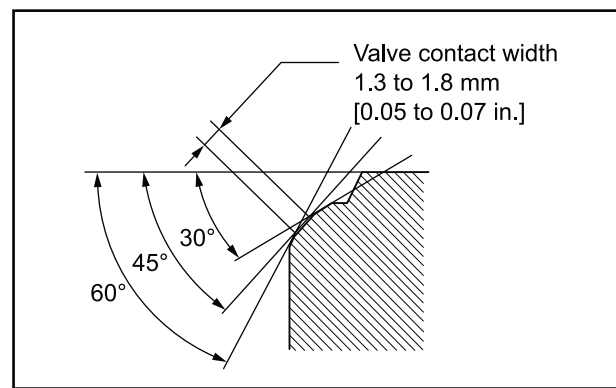

Valve seat face angle and valve seat width

1.10 Lapping valve and valve seat

Always lap the valve against the valve seat after refacing the valve seat or after replacing the valve.

- (1) Apply a thin coat of lapping compound evenly to the valve face.

Note: (a) Do not allow the compound to adhere on the valve stem.

- (b) Compound spreads more evenly if it is mixed with a small amount of engine oil.
 - (c) Use medium-grain compound (120 to 150 mesh) for initial lapping, then use fine-grain compound (200 mesh or finer) for finishing.
- (2) Use a valve lapper for lapping. Strike the valve against the valve seat while rotating the valve little by little.
 - (3) Wash off the compound using diesel fuel.
 - (4) Coat the contact surface of the valve with engine oil, then lap the valve again.
 - (5) Check valve-to-seat contact.

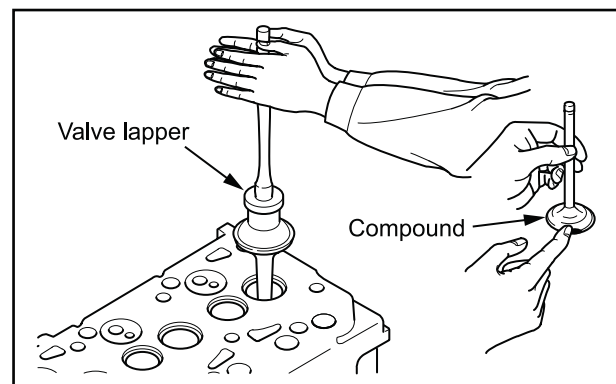

Lapping valve and valve seat

INSPECTION AND REPAIR OF BASIC ENGINE

1.11 Removing combustion jet

Replace the combustion jet only when it has defect as crack.

- (1) Insert a round bar (approx; $\phi 6$ mm [0.24 in.]) into glow plug hole, and tap the combustion jet inner face perimeter lightly to pull out the combustion jet.

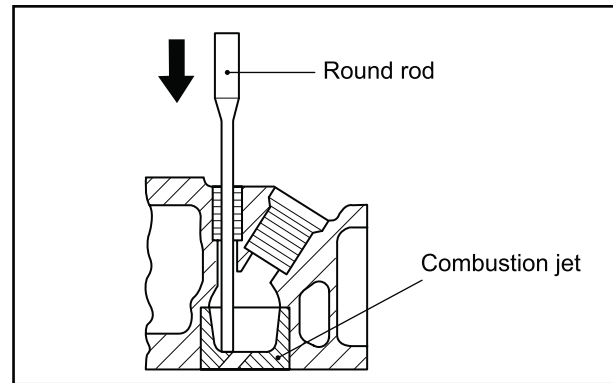

Removing combustion jet

- (2) When installing the combustion jet, align the positioning hole and jet nozzle with the center of cylinder, press fit with tapping by plastic hammer.

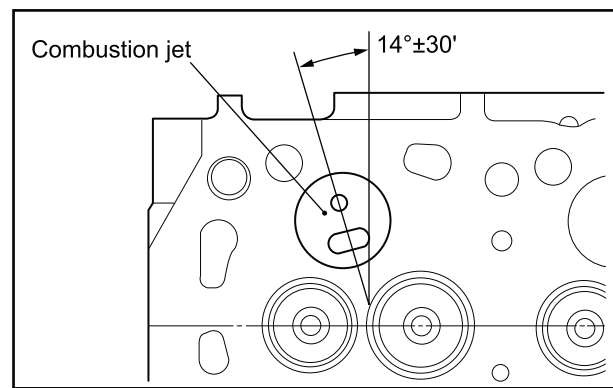

Press-fitting combustion jet

2. Inspecting and repairing flywheel

2.1 Measuring flatness of flywheel

Place the flywheel on a surface plate and move a dial gauge on the friction surface of the flywheel to measure the flatness.

Grind the friction surface of the flywheel if the limit is exceeded.

Item	Standard	Limit
Flywheel flatness	0.15 mm [0.0059 in.] or less	0.50 mm [0.0197 in.]

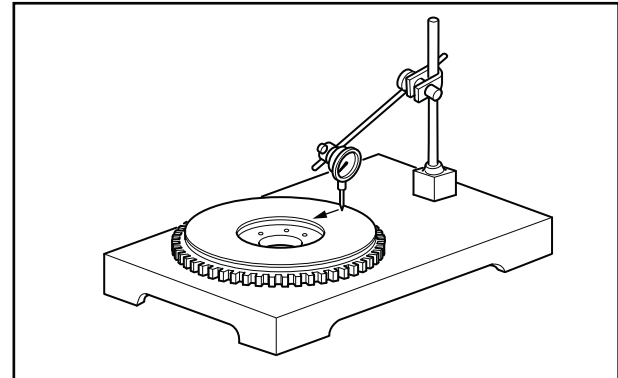

Measuring flatness of flywheel

2.2 Inspecting ring gear

Inspect the ring gear for a missing tooth or worn teeth, and if defects are found, replace the ring gear.

2.3 Replacing ring gear

2.3.1 Removing ring gear

- (1) Heat the ring gear evenly using an acetylene torch or other appropriate heat source.
- (2) With a rod placed on the periphery of ring gear, tap the rod with a hammer evenly around the ring gear, and remove the ring gear.

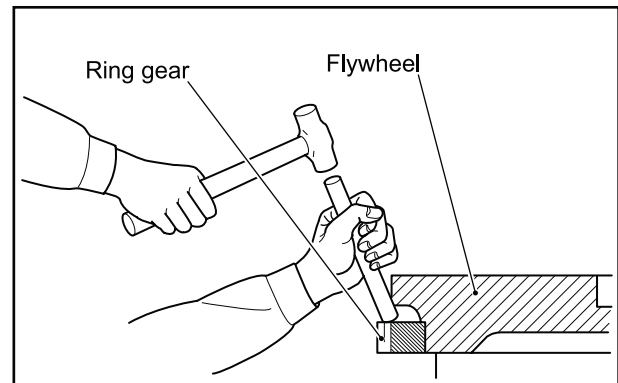

Removing ring gear

2.3.2 Installing ring gear

- (1) Heat the ring gear evenly up to approx. 150°C [176°F] with an appropriate heater.
- (2) Install the ring gear onto the flywheel with the no-gear-chamfering side faced to the flywheel.

Note: Do not heat the ring gear excessively.

INSPECTION AND REPAIR OF BASIC ENGINE

3. Inspecting and repairing gear case, timing gear and camshaft

3.1 Measuring timing gear backlash

Measure the backlash of the timing gears by using one of the following two methods; measure the gear play with the dial gauge plunger applied to a tooth flank on the pitch circle at a right angle to the tooth axis, or measure the clearance between gears by inserting a feeler gauge between the gears at the tooth-to-tooth contacting area. Replace the faulty gear pair if the limit is exceeded.

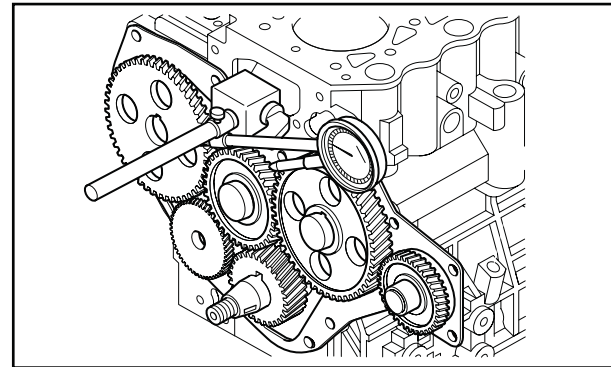

Measuring timing gear backlash

Item		Standard	Limit
Timing gear backlash	Between crankshaft gear and idler gear	0.04 to 0.12 mm [0.0016 to 0.0047 in.]	0.30 mm [0.0118 in.]
	Between idler gear and valve camshaft gear		
	Between idler gear and pump camshaft gear		
	Between valve camshaft gear and PTO gear	0.08 to 0.19 mm [0.0031 to 0.0075 in.]	
	Between pump camshaft gear and oil pump gear	0.07 to 0.20 mm [0.0028 to 0.0079 in.]	

3.2 Measuring clearance between idler gear and idler shaft

Measure the inside diameter of the idler gear and outside diameter of the idler shaft. Replace the idler gear or idler shaft if the clearance exceeds the limit.

Item	Standard	Limit
Clearance between idler gear and idler shaft	0.02 to 0.07 mm [0.0008 to 0.0028 in.]	0.20 mm [0.0079 in.]

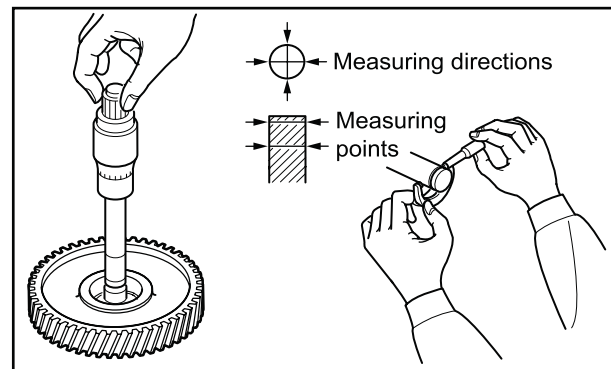

Measuring clearance between idler gear and idler shaft

3.3 Replacing idler shaft

Press-fit the idler shaft into the cylinder block to the dimension in the illustration.

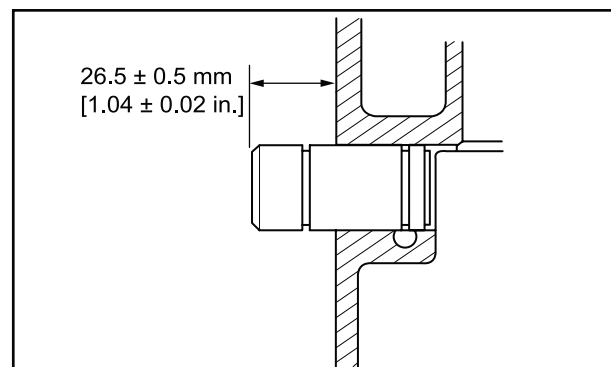

Replacing idler shaft

INSPECTION AND REPAIR OF BASIC ENGINE

3.4 Measuring clearance between camshaft journal and bushing

Calculate the clearance between the outside diameter of the camshaft journal and the inside diameter of the camshaft bushing. Replace the bushing with new one if the clearance exceeds the limit.

Item	Standard	Limit
Clearance between camshaft journal and camshaft bushing	0.050 to 0.125 mm [0.0020 to 0.0049 in.]	0.150 mm [0.0059 in.]

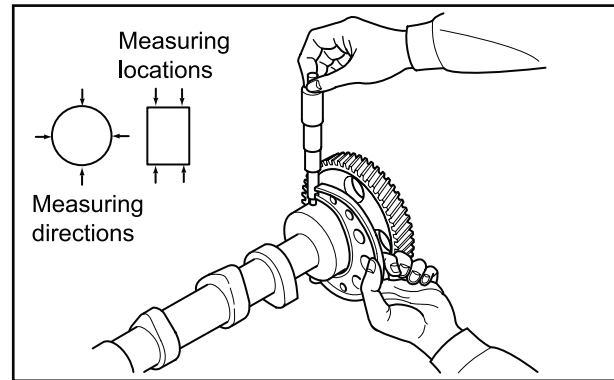

Measuring outside diameter of camshaft journal

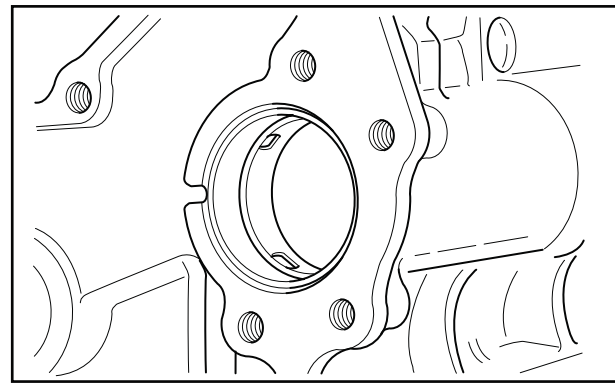

Measuring inside diameter of camshaft bushing

3.5 Replacing camshaft bushing

3.5.1 Removing camshaft bushing

Remove the camshaft bushing with a camshaft bushing installer.

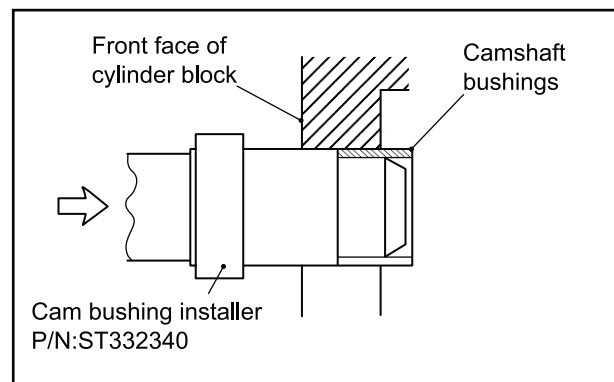

Removing camshaft bushing

3.5.2 Driving in camshaft bushing

When driving in a bushing, match the oil pressure of the oil gallery and the bushing.

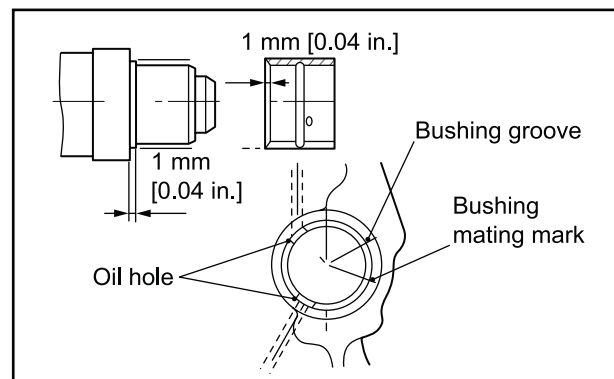

Driving in camshaft bushing

INSPECTION AND REPAIR OF BASIC ENGINE

3.6 Measuring cam lift

Measure the major axis of each cam. If it is less than the limit, replace the camshaft with a new one.

Item	Standard	Limit
Cam height of camshaft (major axis)	35.62 to 35.82 mm [1.4024 to 1.4102 in.]	34.72 mm [1.3669 in.]

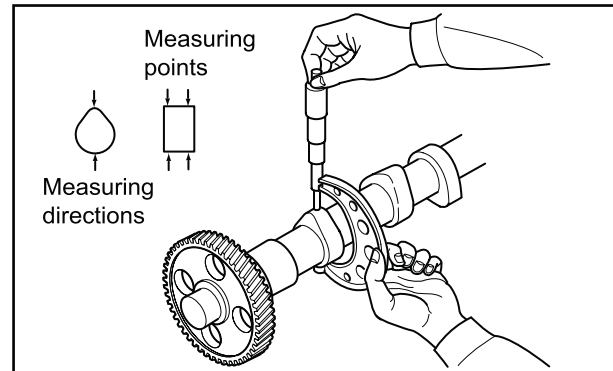

Measuring camshaft cam height

3.7 Measuring cam height of fuel injection pump camshaft

Measure the cam height. Replace the camshaft if the height is less than the limit.

Item	Standard	Limit
Cam height of fuel injection pump camshaft (longer diameter)	43.9 to 44.1 mm [1.728 to 1.736 in.]	43 mm [1.69 in.]

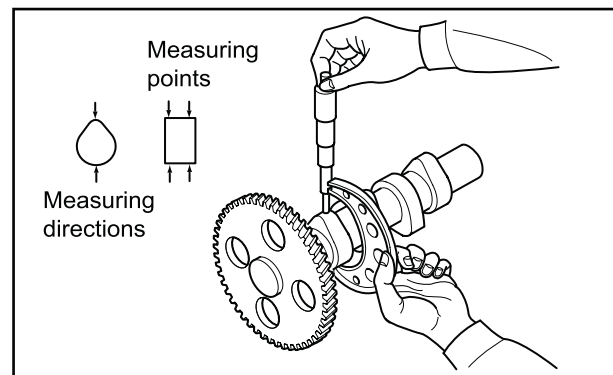

Measuring fuel injection pump camshaft cam height

3.8 Inspecting tappet

Inspect the cam contact surface of the tappets. Fit new tappets if the surface is excessively worn or damaged.

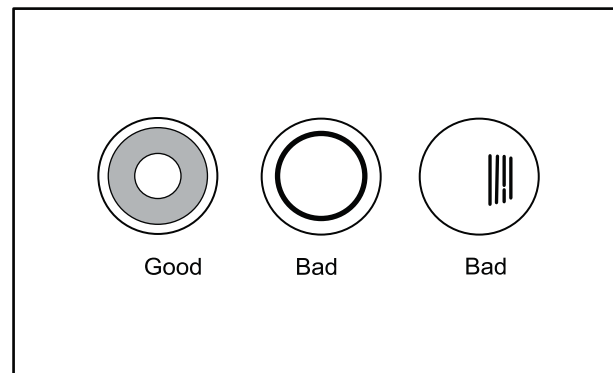

Contact surface of tappet and cam

3.9 Measuring clearance between tappet and tappet guide hole

Measure clearance between the tappet and tappet hole. Replace the tappet with a new one if the limit is exceeded.

Item	Limit
Clearance between tappet and tappet hole	0.15 mm [0.0059 in.]

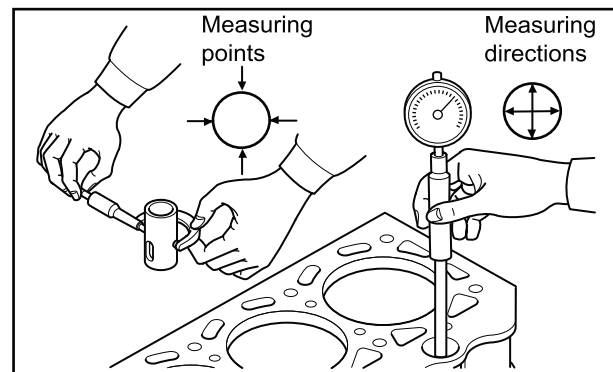

Measuring clearance between tappet and tappet guide hole

INSPECTION AND REPAIR OF BASIC ENGINE

4. Inspecting and repairing cylinder block, crankshaft and piston

4.1 Measuring cylinder inside diameter

Use a cylinder gauge to measure the inside diameter and cylindricity of the cylinder at three locations in the A and B directions as shown in the illustration.

If any one of the cylinders exceeds the repair limit, bore all the cylinders and replace the pistons and piston rings with oversize ones.

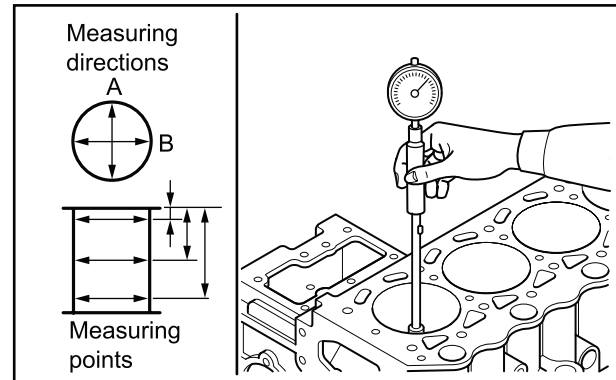

Measuring cylinder inside diameter

Piston and piston ring size		Cylinder inside diameter	
Size	Size mark	Standard	Limit
S.T.D	STD	$\varnothing 78^{+0.060}_{+0.030}$ mm [3.0709 ^{+0.024} _{+0.012} in.]	Standard +0.2 mm [0.008 in.]
0.25 mm O.S [0.0098 in.]	25	$\varnothing 78.25^{+0.060}_{+0.030}$ mm [3.0807 ^{+0.024} _{+0.012} in.]	
0.50 mm O.S [0.0197 in.]	50	$\varnothing 78.50^{+0.060}_{+0.030}$ mm [3.0905 ^{+0.024} _{+0.012} in.]	
Cylindricity of cylinder		± 0.01 mm [0.0004 in.] or less	-

4.2 Measuring piston outside diameter

Using a micrometer, measure the piston outside diameter at the skirt perpendicular to the piston pins as shown in the illustration.

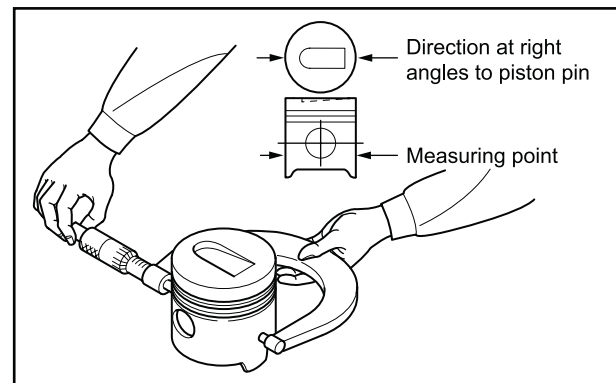

Measuring piston outside diameter

Item	Nominal	Standard	Limit	
Piston outside diameter	STD	78.00 mm [3.0709 in.]	77.93 to 77.95 mm [3.0681 to 3.0689 in.]	77.80 mm [3.0630 in.]
	0.25 OS	78.25 mm [3.0807 in.]	78.18 to 78.20 mm [3.0779 to 3.0787 in.]	78.05 mm [3.0728 in.]
	0.50 OS	78.50 mm [3.0905 in.]	78.43 to 78.45 mm [3.0878 to 3.0886 in.]	78.30 mm [3.0827 in.]
Weight difference per piston		± 5 g [0.18 oz.] or less	-	

INSPECTION AND REPAIR OF BASIC ENGINE

4.3 Measuring piston ring groove

CAUTION

Remove carbon deposits from pistons and check the entire circumference of the piston.

- (1) Remove deposits such as carbon from each ring groove.
- (2) Check each ring groove for wear or damage. If it is worn or damaged, replace the piston with a new one.
- (3) Insert the piston ring into the piston ring groove. Apply a straight edge and insert thickness gauges to measure the clearance between ring and ring groove.

If the limit is exceeded, replace the piston ring with a new one.

Item		Standard	Limit
Clearance between piston ring and ring groove	No.1 compression ring	0.09 to 0.11 mm [0.0035 to 0.0043 in.]	0.30 mm [0.0118 in.]
	No.2 compression ring	0.07 to 0.11 mm [0.0028 to 0.0043 in.]	0.20 mm [0.0079 in.]
	Oil ring	0.03 to 0.07 mm [0.0012 to 0.0028 in.]	0.20 mm [0.0079 in.]

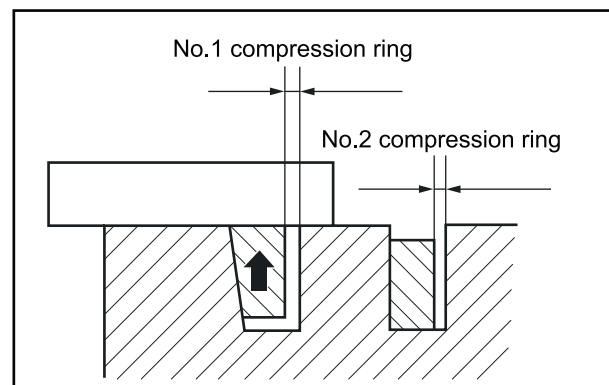

Measuring piston ring groove

4.4 Measuring piston ring end gap

CAUTION

- (a) When replacing rings without boring (honing), measure the end gap at the bottom of the cylinder where the wear is minimum.
- (b) When replacing the ring, use the ring of the same size as the piston.

Insert the piston ring into the cylinder bore and push it with the piston to achieve squareness. Then measure the end gap with feeler gauges. Replace the piston ring if the limit is exceeded.

Item		Standard	Limit
Piston ring end gap	No.1 compression ring	0.15 to 0.30 mm [0.0059 to 0.0118 in.]	1.50 mm [0.0591 in.]
	No.2 compression ring	0.15 to 0.35 mm [0.0059 to 0.0138 in.]	
	Oil ring	0.20 to 0.40 mm [0.0079 to 0.0157 in.]	

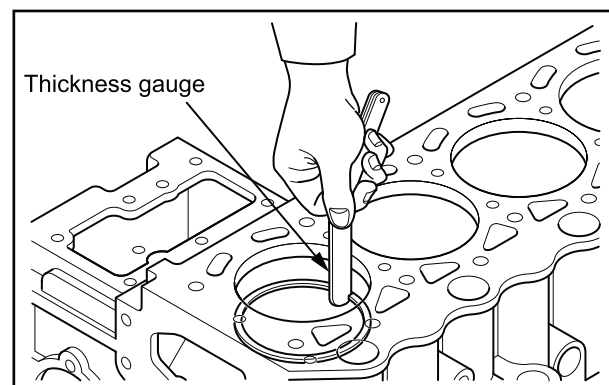

Measuring piston ring end gap

INSPECTION AND REPAIR OF BASIC ENGINE

4.5 Measuring piston pin bore diameter and piston pin outside diameter

Measure the piston pin bore diameter and piston pin outside diameter. Replace if the limit is exceeded.

Item	Nominal	Standard	Limit
Piston pin outside diameter	∅ 23 mm [0.91 in.]	22.944 to 23.000 mm [0.9033 to 0.9055 in.]	-
Clearance between piston pin bore and piston pin outside diameter	-	0.006 to 0.018 mm [0.0002 to 0.0007 in.]	0.050 mm [0.0020 in.]

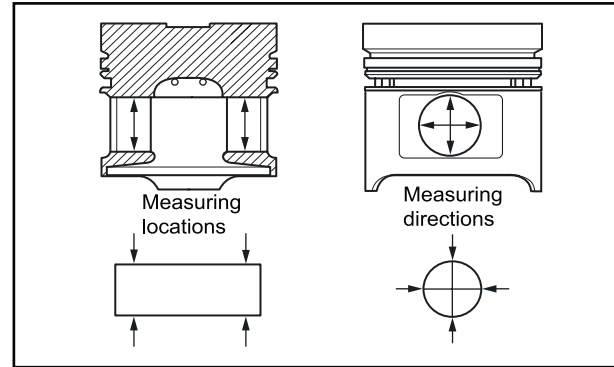

Measuring piston pin bore and piston pin

4.6 Inspecting connecting rod bend and twist

- (1) Measure the dimensions of C and L in the illustration to check bend and twist of the connecting rod. Straighten the connecting rod with a press to meet the standard. If the standard is exceeded after correction, replace the connecting rod with a new one.

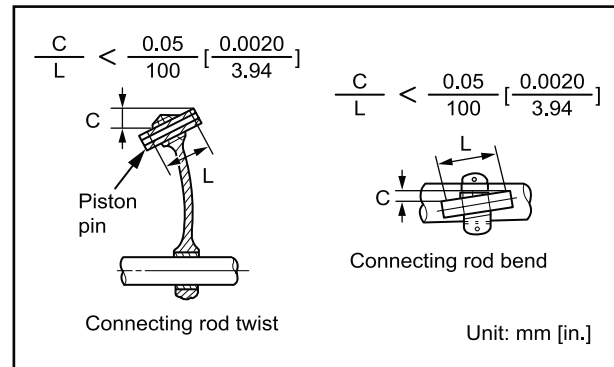

Inspecting connecting rod bend and twist

- (2) In general, a connecting rod aligner is used to check bend and twist.

Note: Before checking bend, tighten the connecting rod cap to the specified torque.

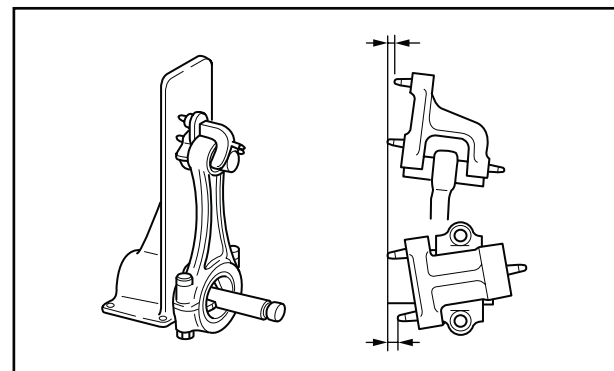

Measurement with connecting rod aligner

- (3) To inspect the connecting rod with the piston installed, turn the piston upside down and place it on a surface plate. Insert a round bar having the same diameter as the crankpin into the big-end bore, and measure the height of the bar using a dial gauge.

Item	Standard	Limit
Bend and twist of connecting rod	0.05/100 mm [0.0020/3.94 in.] or less	0.15/100 mm [0.0059/3.94 in.]

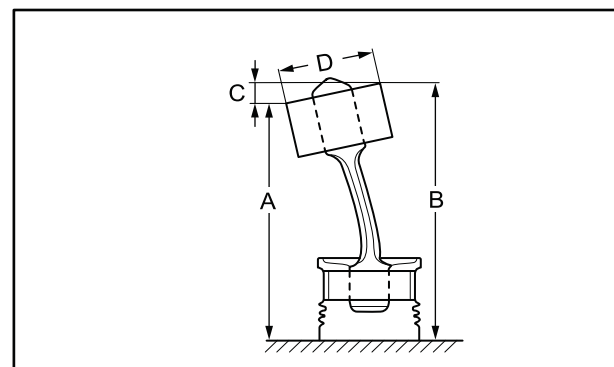

Measuring bend of connecting rod

INSPECTION AND REPAIR OF BASIC ENGINE

4.7 Measuring connecting rod end play

- (1) Install the connecting rods onto the respective crankpins and tighten the connecting rod cap bolts to the specified torque.
- (2) Measure the clearance to the crank arm (end play) at two positions (above and below the crankpin).
- (3) If the limit is exceeded, replace the connecting rod with a new one.

Item	Standard	Limit
Connecting rod end play	0.10 to 0.35 mm [0.0039 to 0.0138 in.]	0.50 mm [0.0197 in.]

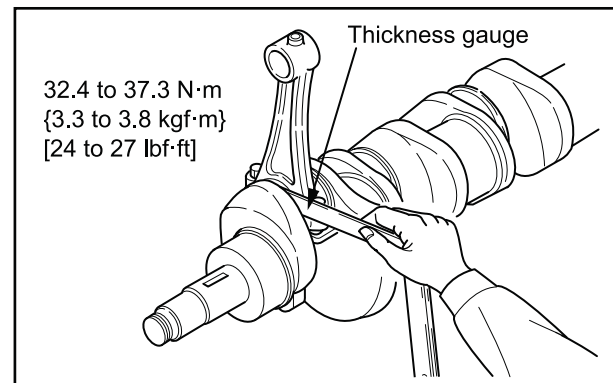

Measuring connecting rod end play

INSPECTION AND REPAIR OF BASIC ENGINE

4.8 Measuring clearance between connecting rod bearing and crankpin

CAUTION

When grinding crank pins, be sure to grind all the pins to the same size.

Finish the fillet radius to the specified dimension.

- (1) Reassemble the bearing into the big end of the connecting rod.
- (2) Tighten the connecting rod cap bolts to the specified torque.
- (3) Measure the inside diameter of the connecting rod bearing.
- (4) Measure the outside diameter of the crank pin.
- (5) Calculate the clearance from the difference between the inside diameter of the connecting rod bearing and outside diameter of the crank pin.
- (6) Replace the connecting rod bearing if the clearance exceeds the limit.
- (7) Measure the clearance between the connecting rod bearing and the crank pin again. Use the undersize bearing if the limit is exceeded.
- (8) If an undersize bearing is used, grind the crank pin to the specified undersize.

Item	Nominal	Standard	Limit
Pin outside diameter (STD)	ø 48 mm [1.89 in.]	47.950 to 47.965 mm [1.8878 to 1.8884 in.]	-
Oil clearance	-	0.025 to 0.072 mm [0.0010 to 0.0028 in.]	0.150 mm [0.0059 in.]

Item	Undersize	Finish dimension
Crankpin undersize	0.25 mm [0.0098 in.]	ø 47.75 ^{-0.035} _{-0.050} mm [1.8799 ^{-0.0014} _{-0.0020} in.]
	0.50 mm [0.0197 in.]	ø 47.50 ^{-0.035} _{-0.050} mm [1.8701 ^{-0.0014} _{-0.0020} in.]
	0.75 mm [0.0295 in.]	ø 47.25 ^{-0.035} _{-0.050} mm [1.8602 ^{-0.0014} _{-0.0020} in.]

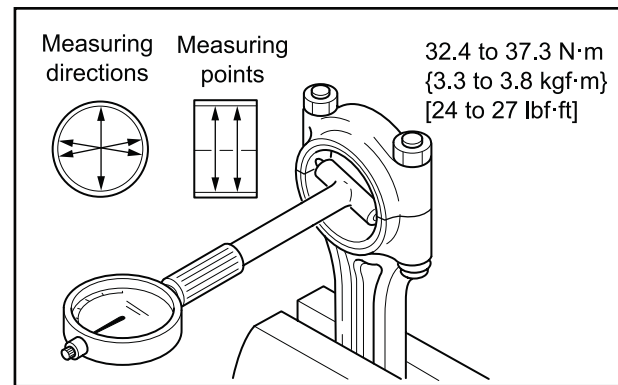

Measuring connecting rod bearing inside diameter

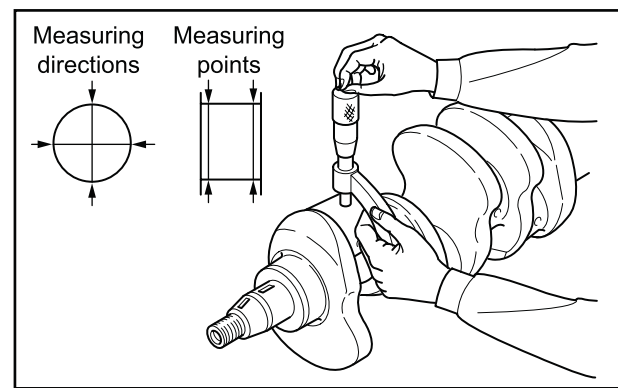

Measuring crankpin outside diameter

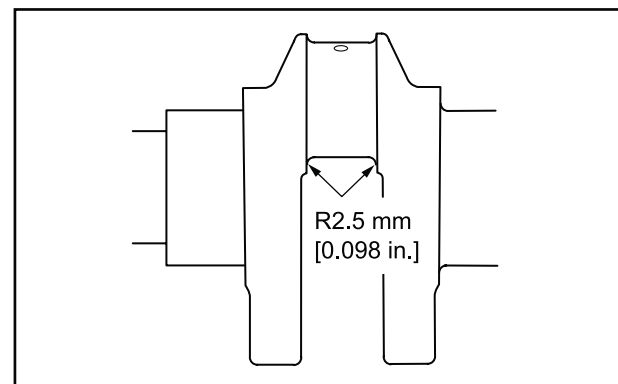

Finish dimension of fillet radius

INSPECTION AND REPAIR OF BASIC ENGINE

4.9 Measuring clearance between main bearing and crankshaft journal

CAUTION

- (a) When grinding crank journals, be sure to grind all the journals to the same size.
- (b) Finish the fillet radius to the specified dimension.
 - (1) Reassemble main bearings.
 - (2) Tighten the main bearing caps to the specified torque.
 - (3) Measure the inside diameter of the main bearings.
 - (4) Measure the outside diameter of the crank journal.
 - (5) Calculate the clearance between the inside diameter of the main bearing and outside diameter of the crank journal.
 - (6) Replace the main bearing if the clearance exceeds the limit.
 - (7) Measure the clearance between the main bearing cap and the crank journal again. Use the undersize bearing if the limit is exceeded.
 - (8) If an undersize bearing is used, grind the crank journal to the specified undersize.

Item	Nominal	Standard	Limit
Outside diameter of journal (S.T.D)	ø 52 mm [2.05 in.]	51.985 to 52.000 mm [2.0466 to 2.0472 in.]	-
Oil clearance	-	0.030 to 0.077 mm [0.0012 to 0.0030 in.]	0.100 mm [0.0039 in.]

Item	Undersize	Finish dimension
Crankpin undersize	0.25 mm [0.0098 in.]	ø 51.75 ⁰ _{-0.015} mm [2.0374 ⁰ _{-0.0006} in.]
	0.50 mm [0.0197 in.]	ø 51.50 ⁰ _{-0.015} mm [2.0276 ⁰ _{-0.0006} in.]
	0.75 mm [0.0295 in.]	ø 51.25 ⁰ _{-0.015} mm [2.0177 ⁰ _{-0.0006} in.]

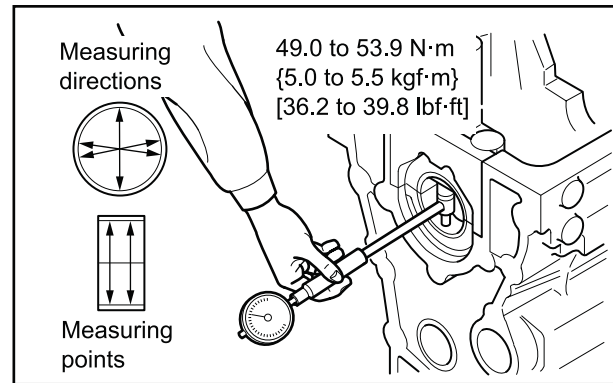

Measuring main bearing fitting bore

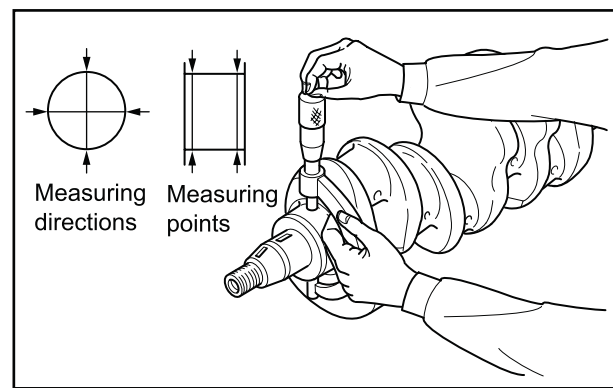

Measuring crank journal outside diameter

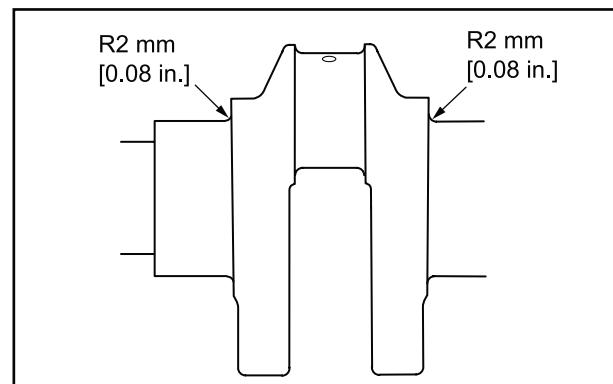

Width of crankshaft thrust bearing surface

INSPECTION AND REPAIR OF BASIC ENGINE

4.10 Measuring crankshaft runout

Support the crankshaft at the front and rear journals with V-blocks, and measure the crankshaft runout at the center journal using a dial gauge. If the runout deviates from the standard only slightly, grind the crankshaft to repair. If the runout exceeds the standard considerably, straighten the crankshaft using a press.

If the limit is exceeded, replace the crankshaft.

If the crankshaft has been repaired by grinding or pressing, inspect the crankshaft for cracks and other harmful damage using a magnetic particle method.

Item	Standard	Limit
Crankshaft runout (TIR)	0.025 mm [0.0010 in.] or less	0.050 mm [0.0020 in.]

4.11 Replacing crankshaft gear

4.11.1 Removing crankshaft gear

Using a gear puller, remove the gear from the crankshaft.

Note: Do not strike the gear with a hammer.

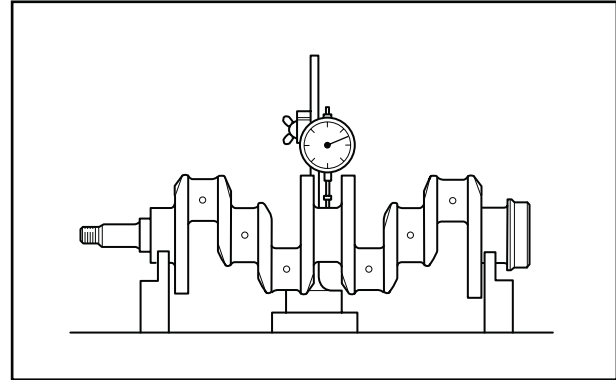

Measuring crankshaft runout

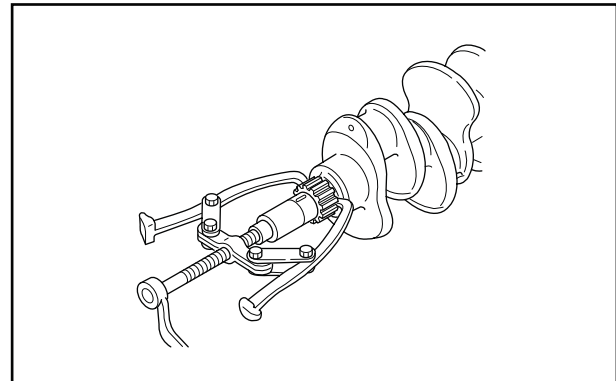

Removing crankshaft gear

4.11.2 Installing crankshaft gear

- (1) Install the key on the crankshaft.
- (2) Press-fit the gear fully in alignment with the key.

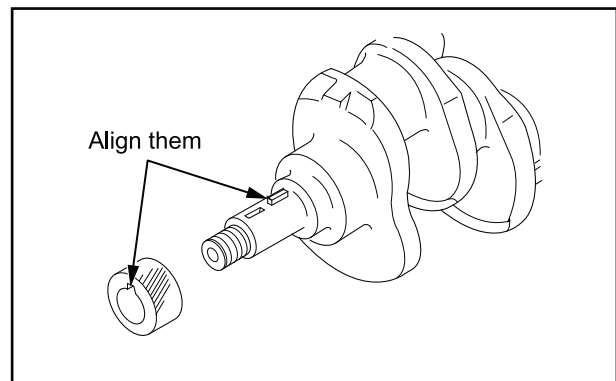

Removing crankshaft gear

INSPECTION AND REPAIR OF BASIC ENGINE

4.12 Measuring distortion cylinder block top surface

CAUTION

Refacing of cylinder block should be kept to an absolute minimum.

Excessive grinding of the crankcase may result in defects such as defective combustion and stamping (contact between piston and valve).

Measure the distortion of the crankcase top surface with a straight edge and feeler gauge. If the measurement exceeds the limit, grind the top surface with a surface grinder.

Item	Standard	Limit
Distortion of cylinder block top surface	0.05 mm [0.0020 in.] or less	0.10 mm [0.0039 in.]

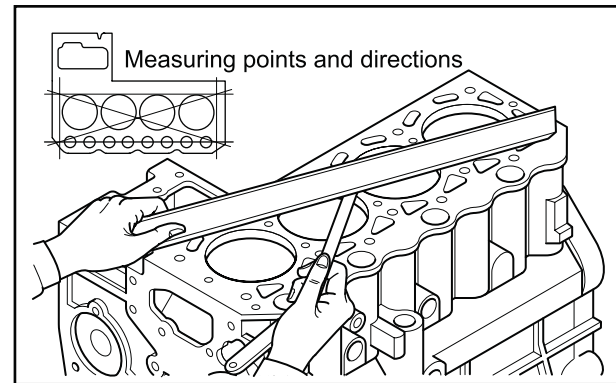

Measuring distortion cylinder block top surface

REASSEMBLY OF BASIC ENGINE

1. Reassembling cylinder block, crankshaft, piston and oil pan	D-58
1.1 Installing main bearing	D-58
1.2 Installing crankshaft	D-58
1.3 Installing main bearing cap	D-59
1.4 Inserting side seal	D-59
1.5 Installing main bearing cap bolt	D-60
1.6 Measuring crankshaft end play	D-60
1.7 Reassembling piston and connecting rod	D-61
1.8 Installing piston ring	D-62
1.9 Installing piston and connecting rod	D-62
1.10 Installing connecting rod cap	D-63
1.11 Installing oil strainer.	D-63
1.12 Installing oil pan	D-64
2. Reassembling flywheel, timing gear and camshaft.	D-65
2.1 Installing front plate	D-65
2.2 Installing oil pump	D-65
2.3 Rotating crankshaft	D-65
2.4 Installing fuel injection pump camshaft	D-65
2.5 Installing camshaft	D-66
2.6 Installing idler gear	D-66
2.7 Installing timing gear case	D-66
2.8 Installing crankshaft pulley	D-67
2.9 Installing PTO gear	D-67
2.10 Installing tappet.	D-67
2.11 Installing oil seal case	D-67
2.12 Installing rear plate	D-68
2.13 Installing flywheel housing	D-68
2.14 Installing flywheel	D-68
3. Reassembling cylinder head and valve mechanism	D-69
3.1 Cleaning cylinder head bottom surface.	D-69
3.2 Installing valve stem seal	D-69
3.3 Installing valve spring	D-69
3.4 Installing valve lock	D-69
3.5 Installing cylinder head gasket	D-70
3.6 Installing cylinder head assembly	D-70
3.7 Tightening cylinder head bolts	D-70
3.8 Inserting push rod	D-70
3.9 Reassembling rocker shaft assembly	D-71
3.10 Installing rocker shaft assembly	D-71
3.11 Adjusting valve clearance	D-71
3.12 Installing rocker cover	D-71

REASSEMBLY OF BASIC ENGINE

1. Reassembling cylinder block, crankshaft, piston and oil pan

Reassemble the cylinder head and valve mechanisms in the reverse order of the disassembly procedures.

1.1 Installing main bearing

- (1) Install the main bearings (upper and lower) with aligning lug groove of the crankcase and main bearing cap.

Note: Install the bearing (upper) with groove to the crankcase, and install the bearing (lower) without groove to the main bearing cap.

- (2) Install the flange main bearing to the rearmost crankcase mating surface.
- (3) Apply a small amount of engine oil to each bearing.

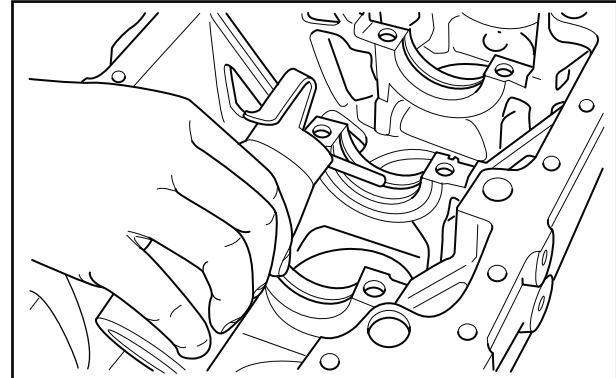

Installing main bearing

1.2 Installing crankshaft

- (1) Wash the crankshaft thoroughly with cleaning oil and dry it completely by compressed air.

Note: When washing the crankshaft, clean the inside of the oil holes completely and make sure that no foreign substances or dirt is present.

- (2) Hold the crankshaft horizontally and slowly install it to the cylinder block.
- (3) Apply a small quantity of engine oil to the crankshaft journals.

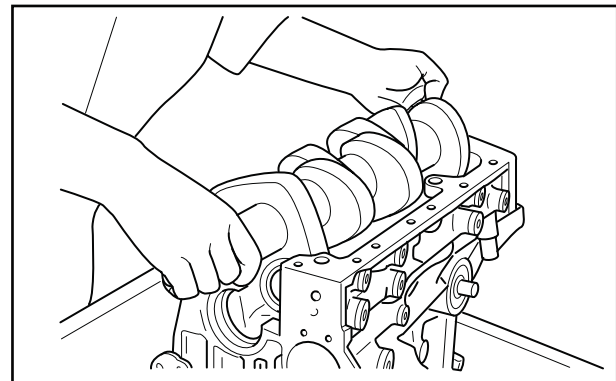

Installing crankshaft

REASSEMBLY OF BASIC ENGINE

1.3 Installing main bearing cap

CAUTION

The foremost and rearmost caps should be installed so that they are flush with the cylinder block surface.

- (1) Apply sealant to the mating surface of the foremost and rearmost caps and the cylinder block mating faces before installing the main bearing caps.

Sealant or lubricant	THREEBOND 1212 or 1211
----------------------	------------------------

- (2) Install the main bearing caps so that their front marks (arrow) and cap numbers are in numerical order from the front of the engine.
- (3) Temporarily tighten bolts.

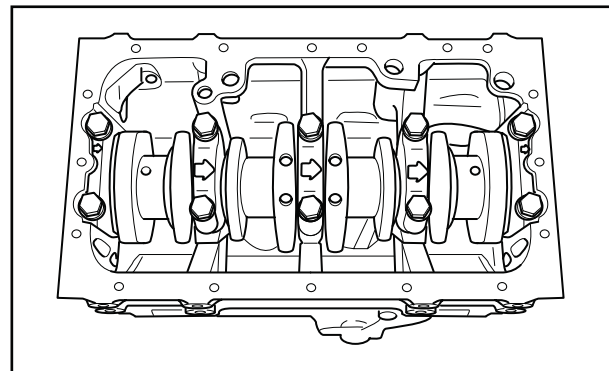

Reassembled position of main bearing cap

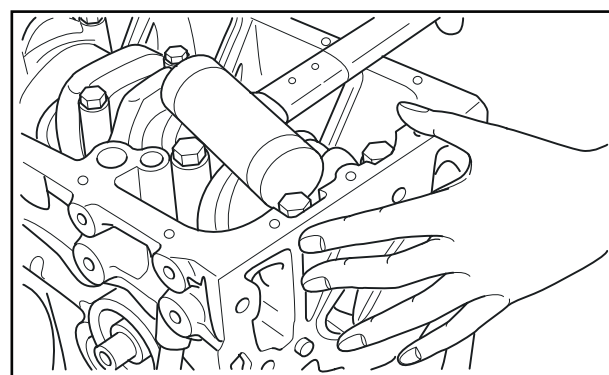

Installing main bearing cap

1.4 Inserting side seal

- (1) Apply a sealant to the outer periphery of new side seals.

Sealant	THREEBOND 1212 or 1211
---------	------------------------

- (2) With the round section of the side seals facing outward, press them partway into the front and rear caps using hands.
- (3) When the side seals are installed partway into caps, use a tool with flat surface such as flat-head screwdriver to install completely, taking care not to bend them.

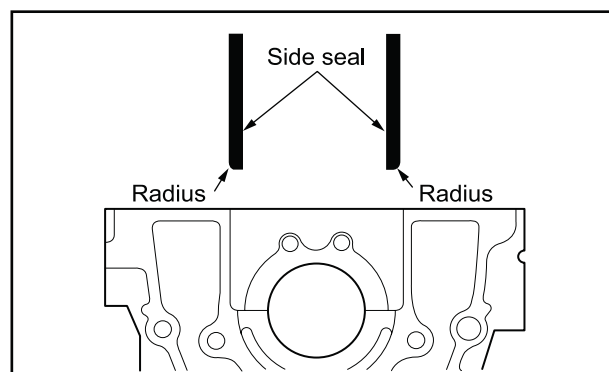

Installing direction of side seal

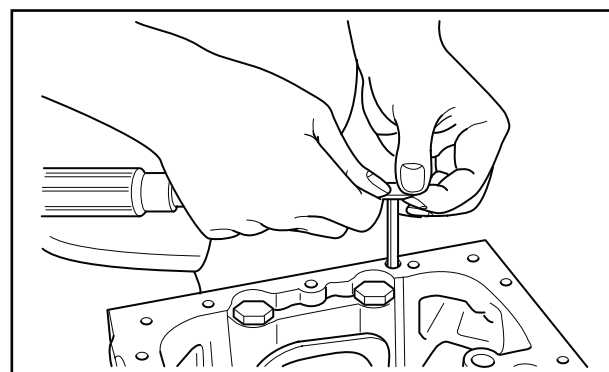

Inserting side seal

REASSEMBLY OF BASIC ENGINE

1.5 Installing main bearing cap bolt

- (1) Tighten the main bearing cap bolts alternately and progressively to the specified torque.
- (2) Make sure that the crankshaft rotates smoothly.

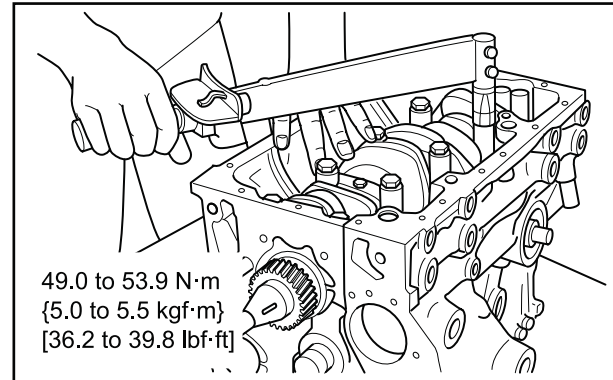

Tightening main bearing cap bolt

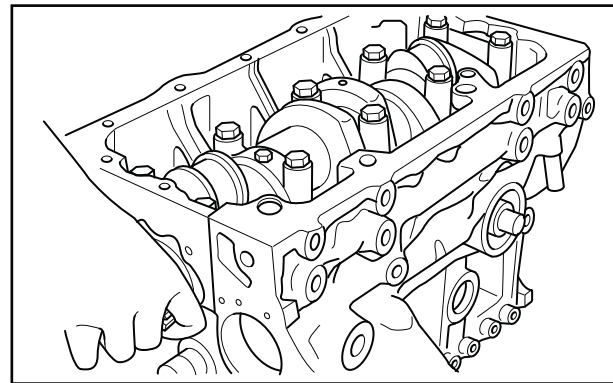

Checking crankshaft for rotation

1.6 Measuring crankshaft end play

Attach a dial gauge to the end of the crankshaft to measure the end play.

If the end play deviates from the standard value, loosen the main bearing cap bolts and retighten.

Make sure that the camshaft turns freely.

Item	Standard	Limit
Measuring crankshaft end play	0.050 to 0.175 mm [0.0020 to 0.0069 in.]	0.500 mm [0.0197 in.]

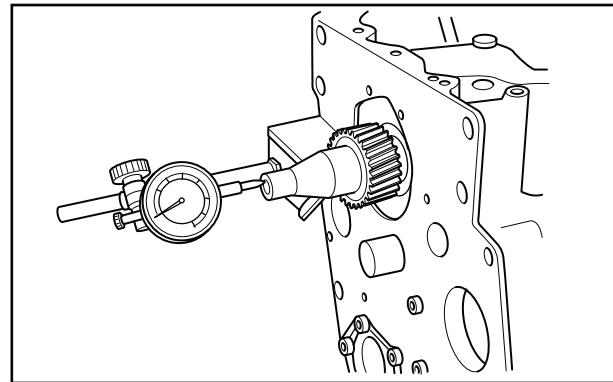

Measuring crankshaft end play

REASSEMBLY OF BASIC ENGINE

1.7 Reassembling piston and connecting rod

(1) With the identification mark of connecting rod facing upward, place the rod on the piston pin setting tool.

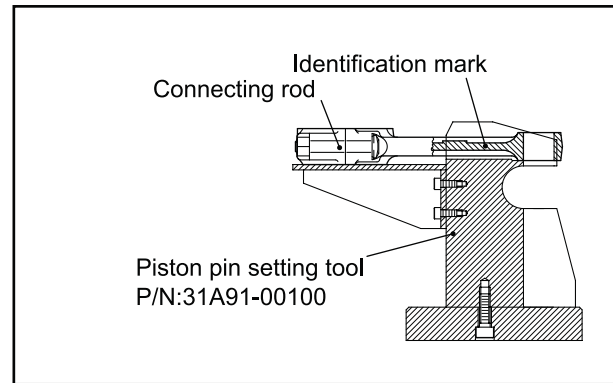

Reassembling piston and connecting rod (1)

(2) Set the piston pin push rod and guide to the piston pin.

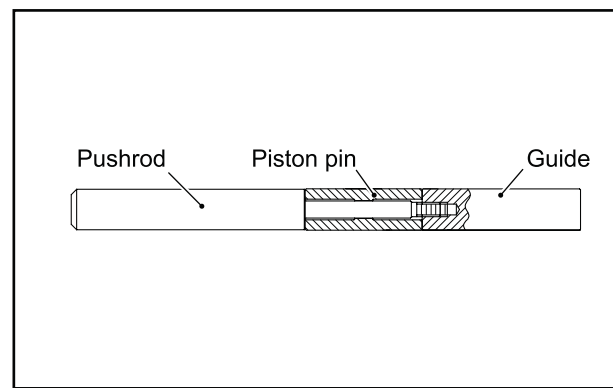

Reassembling piston and connecting rod (2)

(3) Reassemble the piston to the connecting rod with the front mark (Δ) on the piston top and the identification mark of the connecting rod facing upward. Install the piston pin from the piston pin guide.

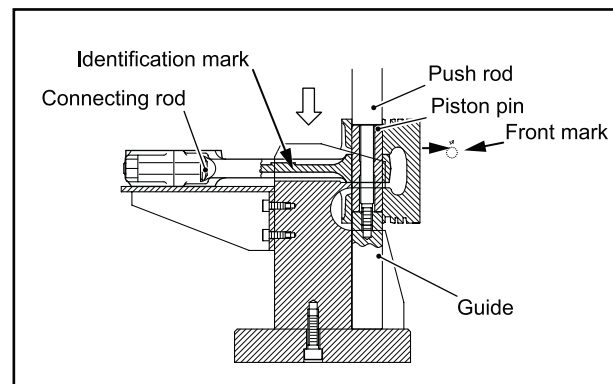

Reassembling piston and connecting rod (3)

(4) Press-in the piston pin with the push rod using hydraulic press (pin press-in load 9807 ± 4903 N { 1000 ± 500 kgf} [2205 ± 1102 lbf]) until the guide contacts the piston setting tool.

(5) After reassembling, make sure that the piston and the connecting rod move lightly on the piston pin.

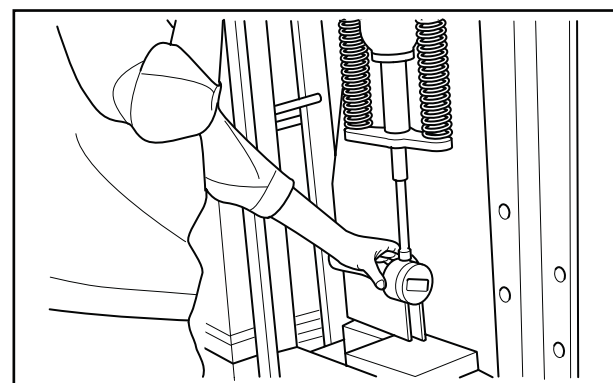

Reassembling piston and connecting rod (4)

REASSEMBLY OF BASIC ENGINE

1.8 Installing piston ring

CAUTION

Every piston ring has a top mark such as "R" near the end gap. Install all piston rings with this mark facing upward.

If the rings are installed upside down, it could cause malfunctions such as excessive oil consumption or an engine seizing.

- (1) Install the piston rings to the piston with a piston ring plier.
- (2) Install the oil ring with its end gap 180° away from the joint of the coil spring, as shown in the illustration.

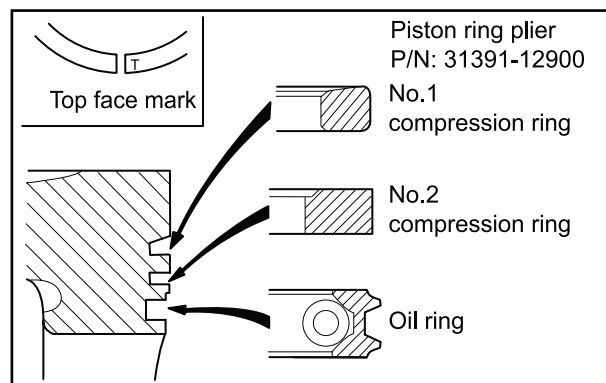

Piston/piston ring orientation

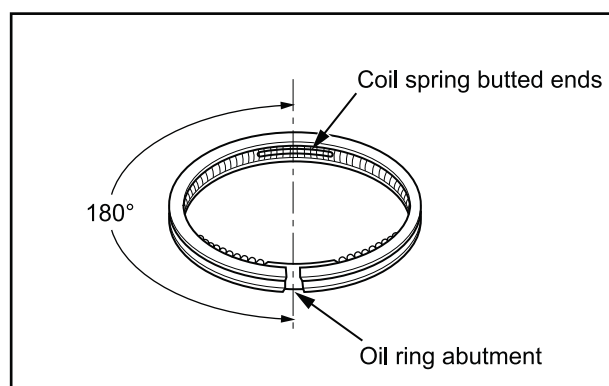

Reassembling oil ring

1.9 Installing piston and connecting rod

CAUTION

Do not forcefully insert the piston, as it may cause damage to the piston rings and crank pin.

- (1) Apply engine oil to the circumference of the piston and piston rings.
- (2) Place the ring end gaps in diagonal positions avoiding the piston pin direction and its right angle direction.
- (3) Fit the connecting rod bearing (upper) to the connecting rod aligning the lug and lug groove.
- (4) Turn the crankshaft to place the crank pin of the assembling cylinder to the top dead center.
- (5) Face the front mark (arrow) stamped on the piston top toward the timing gear case side (forward of the engine).
- (6) Insert the piston from the top face of cylinder block using a piston guide (commercially available).

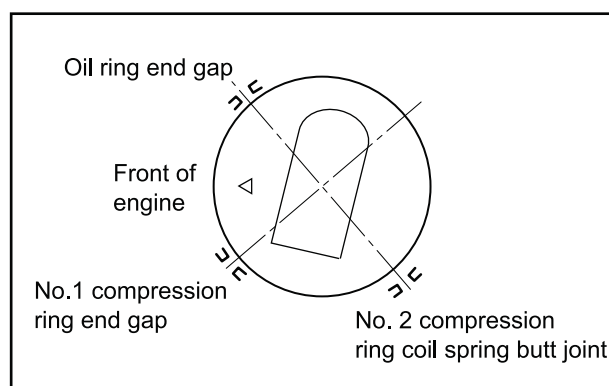

Orienting piston ring end gaps

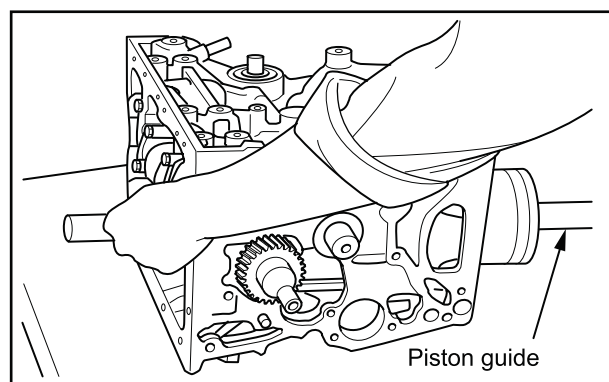

Installing pistons and connecting rods

REASSEMBLY OF BASIC ENGINE

1.10 Installing connecting rod cap

- (1) When the big end of the connecting rod comes into close contact with the crank pin, turn the crankshaft 180° while pressing the piston head.
- (2) Fit the connecting rod bearing (lower) to the rod cap with the lug aligned with the lug groove.
- (3) Install the cap to the connecting rod, aligning the mating marks made during disassembly.

Note: For new connecting rod on which there is no mating mark, orient the lugs of upper and lower bearings on the same side as shown in the illustration.

- (4) Tighten the connecting rod cap nuts evenly and progressively to the specified torque.

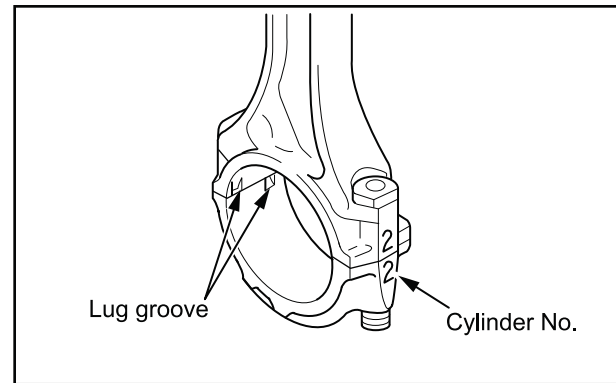

Installing connecting rod caps

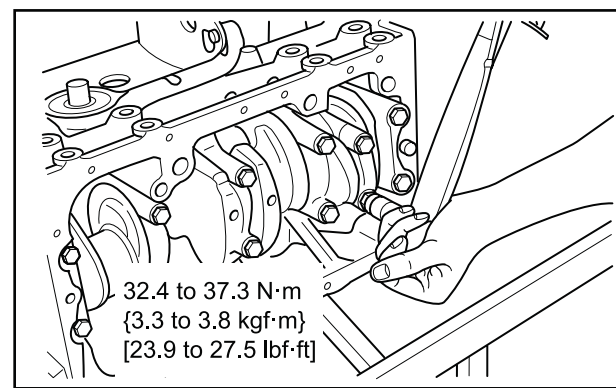

Tightening connecting rod cap nuts

- (5) Inspect end play of the connecting rod. If end play is small, loosen and retighten the cap nuts.

Item	Standard	Limit
End play of connecting rods	0.10 to 0.35 mm [0.0039 to 0.0138 in.]	0.50 mm [0.0197 in.]

1.11 Installing oil strainer

- (1) Invert the cylinder block to face up the oil pan mounting surface.
- (2) Make sure that the end of the strainer does not contact to oil pan, install the strainer and tighten the nut to the specified torque.

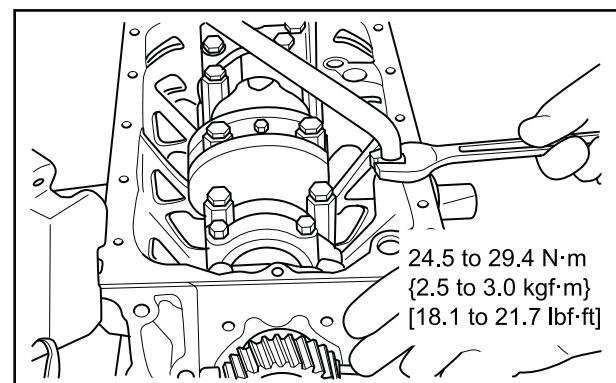

Installing oil strainer

REASSEMBLY OF BASIC ENGINE

1.12 Installing oil pan

- (1) Clean the cylinder block and oil pan mating surfaces.
- (2) Apply sealant (ThreeBond 1207C) to the all circumference of cylinder block mating surface.

Note: (a) Squeeze the sealant in a bead of 4mm, and apply to the specified part shown in the illustration.
(b) Cutting the top of the sealant tube at the point shown in the illustration will provide a 4mm bead.

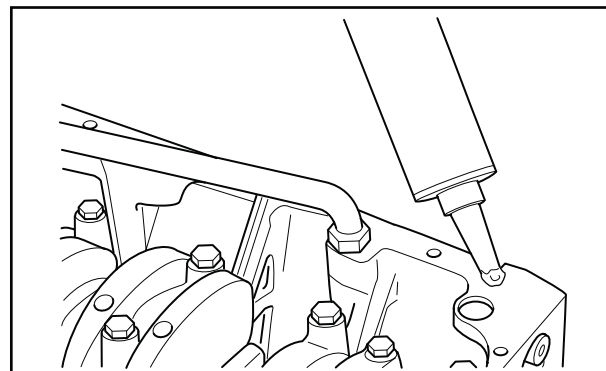

Applying sealant to oil pan mounting face of cylinder block

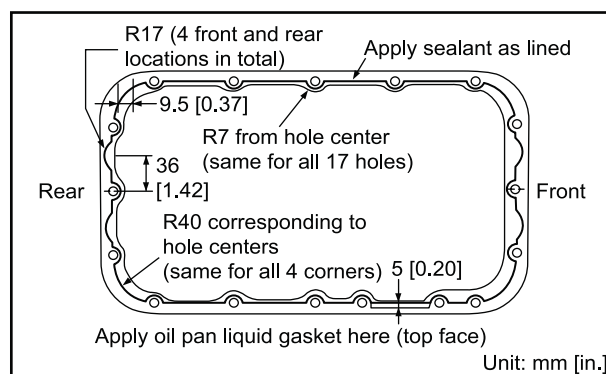

Sealant application pattern

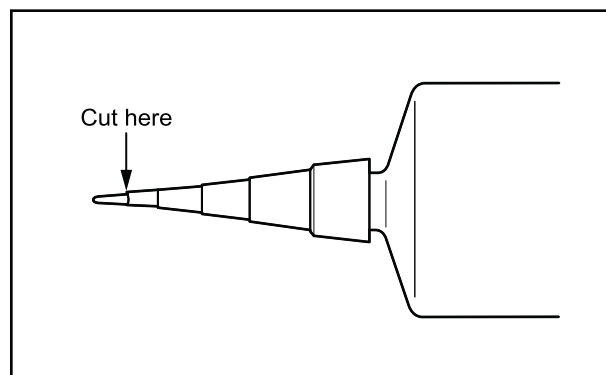

Cutting end of sealant tube

- (3) Install the oil pan.
- (4) Tighten the oil pan mounting bolts diagonally in several steps, and finally to the specified torque.

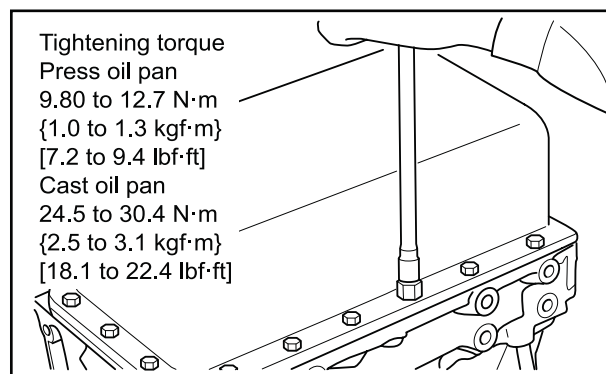

Installing oil pan

REASSEMBLY OF BASIC ENGINE

2. Reassembling flywheel, timing gear and camshaft

Reassemble the cylinder head and valve mechanisms in the reverse order of the disassembly procedures.

2.1 Installing front plate

- (1) Clean the mounting surface of the gasket.
- (2) Apply sealant to the gasket to prevent it from falling.
- (3) With aligning to the dowel pin, install the gasket and the front plate.
- (4) Secure the front plate with mounting bolts.

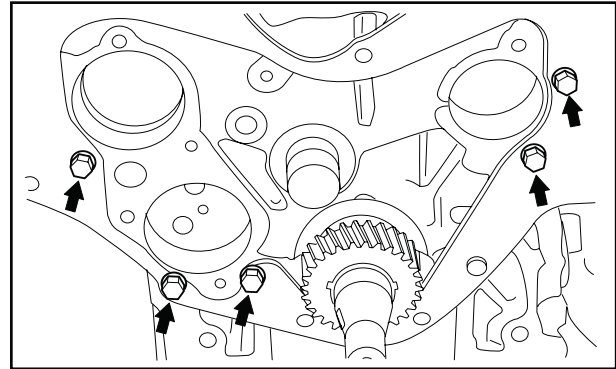

Installing front plate

2.2 Installing oil pump

- (1) Make sure that the packing is installed securely into the oil pump.
- (2) Install the oil pump to the crankcase, and secure it with the bolt.
- (3) Ensure that the oil pump gear rotates smoothly.

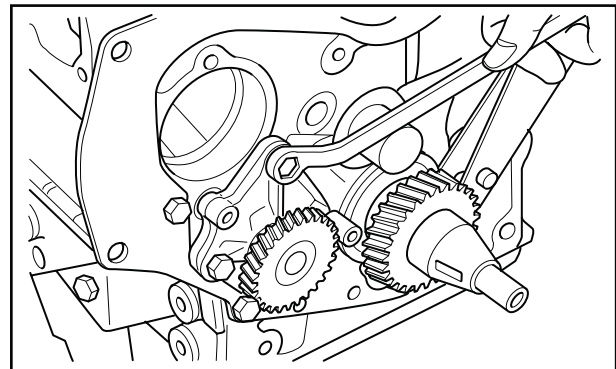

Installing oil pump

2.3 Rotating crankshaft

- (1) Install two bolts in the flywheel mounting holes of the crankshaft.
- (2) Rotate the crankshaft with a bar using the bolts to bring the No.1 cylinder at the top dead center.

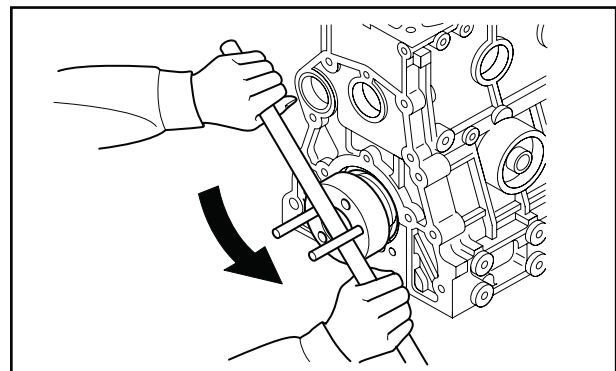

Rotating crankshaft

2.4 Installing fuel injection pump camshaft

- (1) Insert the fuel injection pump camshaft (with the bearing and gear installed) into the cylinder block hole.
- (2) Install the bearing into the cylinder block hole completely by tapping the gear with a plastic hammer.
- (3) Make sure that the fuel injection pump camshaft rotates lightly.
- (4) Tighten the camshaft stopper bolts.

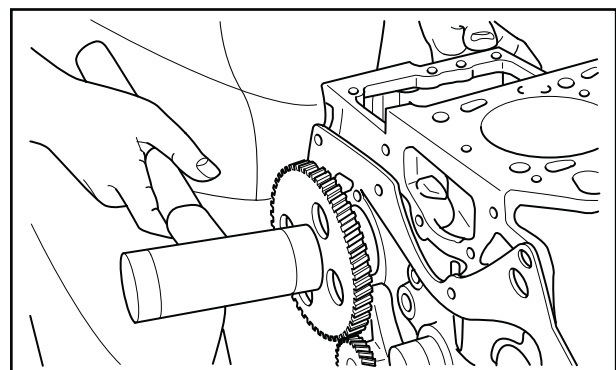

Driving in fuel injection pump shaft

REASSEMBLY OF BASIC ENGINE

2.5 Installing camshaft

CAUTION

Be careful not to damage camshaft journals, cams and camshaft holes during insertion.

- (1) Apply engine oil to the camshaft journals and cams.
- (2) Slowly insert the camshaft assembly.
- (3) Tighten the thrust plate bolt to the specified torque.
- (4) Make sure that the camshaft rotates lightly. Move the camshaft gear back and forth, and make sure there is end play.

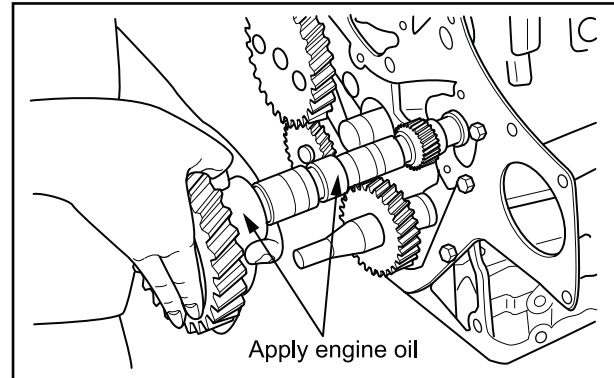

Installing camshaft

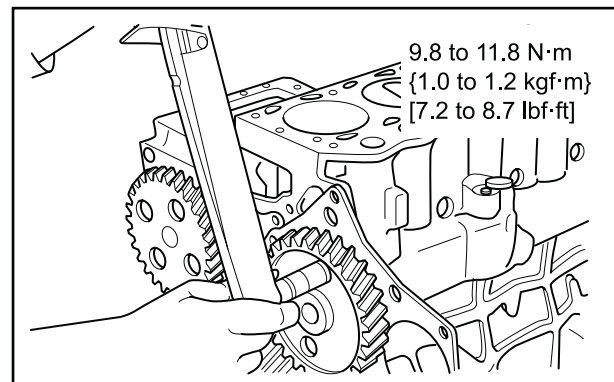

Installing thrust plate

2.6 Installing idler gear

- (1) Apply engine oil to the idler gear shaft.
- (2) With aligning the timing mark, install the idler gear.
- (3) Check the backlash between the gears.

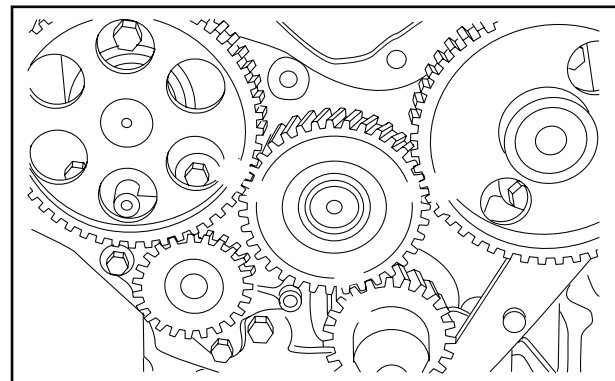

Align the timing marks.

2.7 Installing timing gear case

- (1) Apply sealant to the gasket to prevent it from displacing and install the gasket on the front plate.
- (2) Apply engine oil to the oil seal lip.
- (3) Install the timing gear case and tighten the bolts.

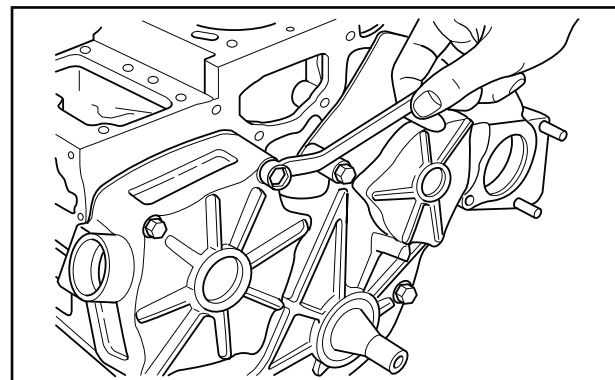

Installing timing gear case

REASSEMBLY OF BASIC ENGINE

2.8 Installing crankshaft pulley

CAUTION

The bar could come off. Be very careful.

- (1) Screw two guide bolts into the threaded holes at the rear end of the crankshaft. Place a bar across the two guide bolts so that the crankshaft does not turn.
- (2) Install the woodruff key on the crankshaft.
- (3) Install the crankshaft pulley and tighten the nuts to the specified torque.

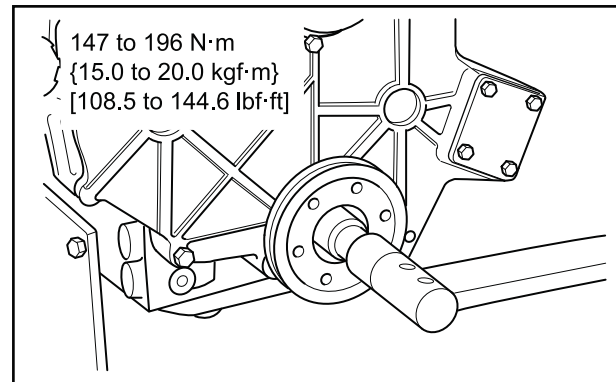

Installing crankshaft pulley

2.9 Installing PTO gear

Drive the PTO gear into the timing gear case. Ensure that the side of the gear with no oil hole face the rear of the engine.

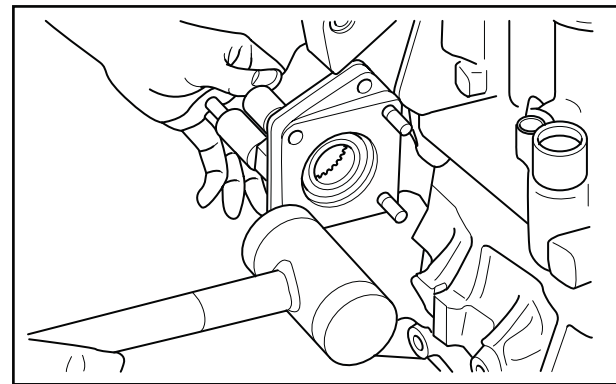

Installing PTO gear

2.10 Installing tappet

Coat the periphery of tappets with engine oil, insert them into the tappet holes and place them gently on the camshafts.

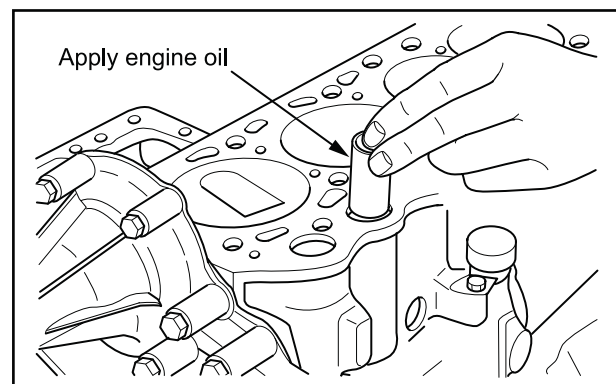

Inserting tappet

2.11 Installing oil seal case

CAUTION

Be careful not to damage the oil seal.

- (1) Install the new oil seal gasket.
- (2) After applying engine oil to the entire circumference of the oil seal lips, install the oil seal case on the cylinder block.

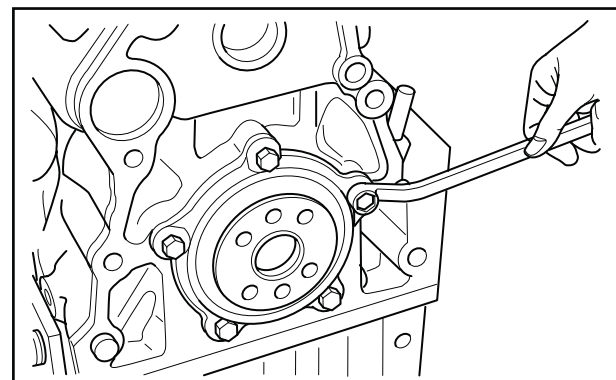

Installing oil seal case

REASSEMBLY OF BASIC ENGINE

2.12 Installing rear plate

- (1) Install a new rear plate gasket.
- (2) Install the rear plate aligning with the dowel pins.
Tighten the mounting bolt to the specified torque.

Note: Install the starter to the rear plate in advance to facilitate the subsequent reassembly.

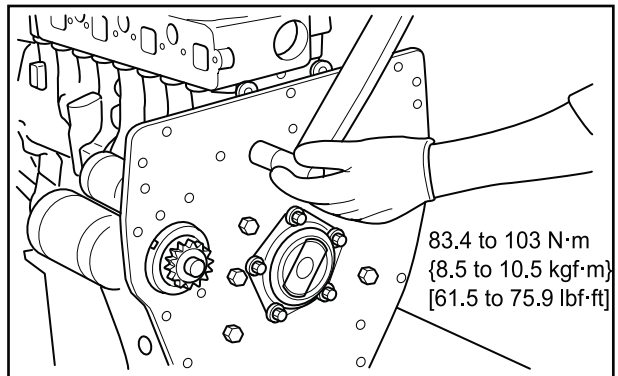

Installing rear plate

2.13 Installing flywheel housing

Install the flywheel housing aligning with the knock pins.
Tighten the mounting bolt evenly.

Note: Replace the knock pins with a new one if the knock pins are worn or if a new flywheel housing is replaced.

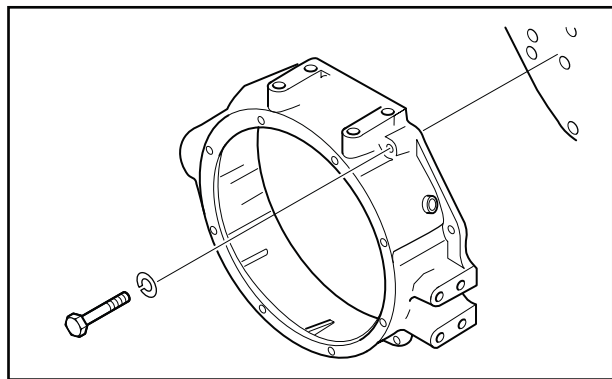

Installing flywheel housing

2.14 Installing flywheel

CAUTION

The person who holds the pulley must be very careful to assure safety by communicating with the person who is installing the flywheel.

- (1) One person must firmly hold the pulley with a wrench to prevent the crankshaft from turning.
- (2) Screw the guide bolt into the rear end of the crankshaft.
- (3) Align the bolt hole of flywheel with the guide bolt and install the flywheel to the crankshaft.
- (4) Temporarily tighten bolts.
- (5) Remove the guide bolt and temporarily tighten the last bolt.
- (6) Tighten the flywheel bolts to the specified torque.

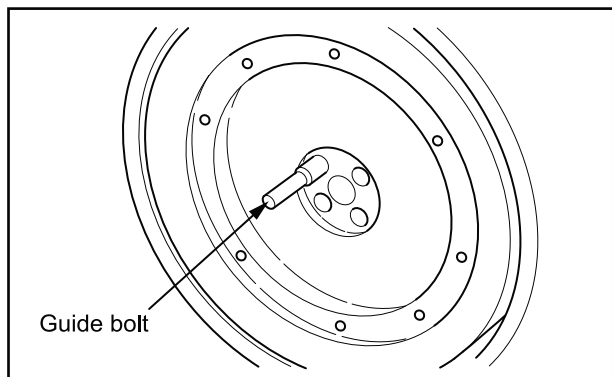

Installing flywheel

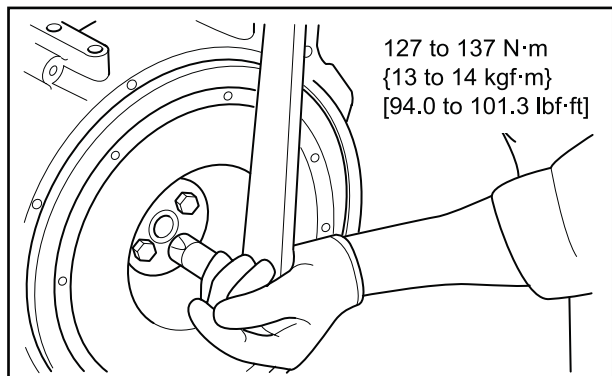

Tightening flywheel

REASSEMBLY OF BASIC ENGINE

3. Reassembling cylinder head and valve mechanism

Reassemble the cylinder head and valve mechanisms in the reverse order of the disassembly procedures.

3.1 Cleaning cylinder head bottom surface

Taking care not to damage the cylinder head bottom surface, remove residue of old gasket.

Note: First, roughly scrape off residue of old gasket using a scraper. Then, grind off the remaining residue using an engine-oil immersed oil stone.

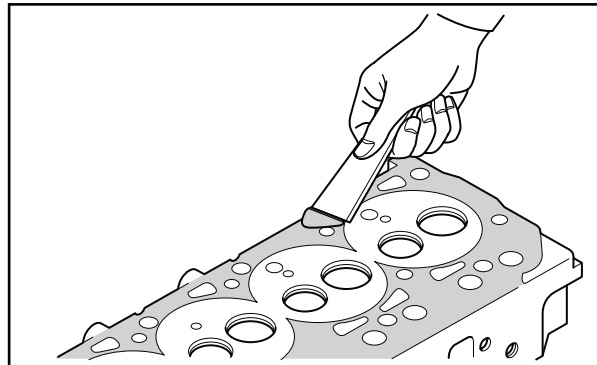

Scraping gasket

3.2 Installing valve stem seal

CAUTION

Do not apply oil or liquid gasket to the inner side of stem seal that comes in contact with the valve guide.

- (1) Apply engine oil to the lip of the valve stem seal.
- (2) Push the shoulder of the valve stem seal and fit the valve stem seal into the valve guide.
- (3) Make sure the valve stem seal is fully inserted into the valve guide.

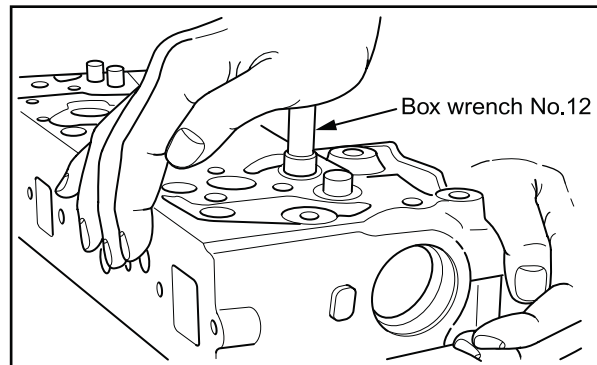

Installing valve stem seal

3.3 Installing valve spring

Install the valve spring with its white or yellow enamel painted side facing upward.

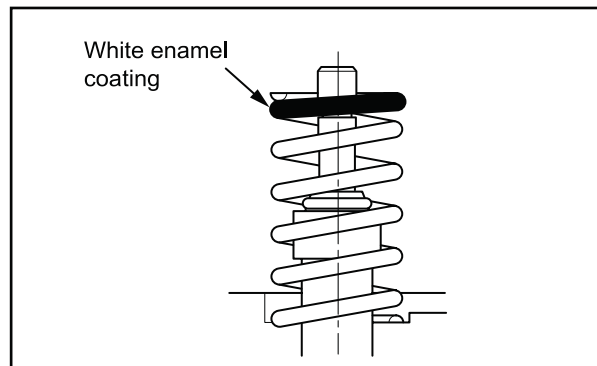

Installing valve spring

3.4 Installing valve lock

CAUTION

If valve spring is overcompressed, the lower end of the retainer comes into contact with the stem seal, and causes damage to the stem seal.

Install the retainer on the valve spring.

Compress the valve spring using a valve lifter, and install the valve locks.

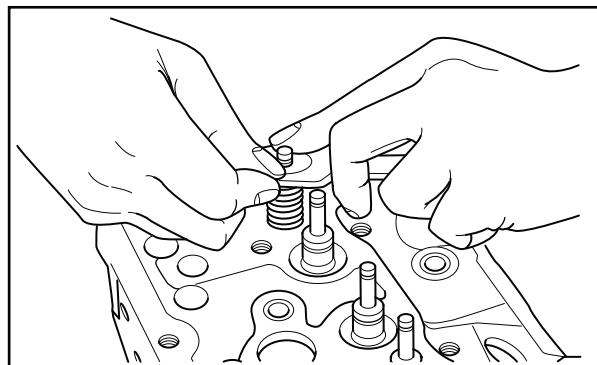

Installing valve lock

REASSEMBLY OF BASIC ENGINE

3.5 Installing cylinder head gasket

CAUTION

Do not use liquid gasket.

- (1) Make sure that there is no dirt or dents on the top surfaces of the cylinder block and pistons.
- (2) Screw in two guide bolts in the bolt holes of the cylinder block.
- (3) Place the new cylinder head gasket on the cylinder block aligning to the guide bolts.

Note: The model name is stamped on the front top face of the gasket so that it is not confused with one for other model.

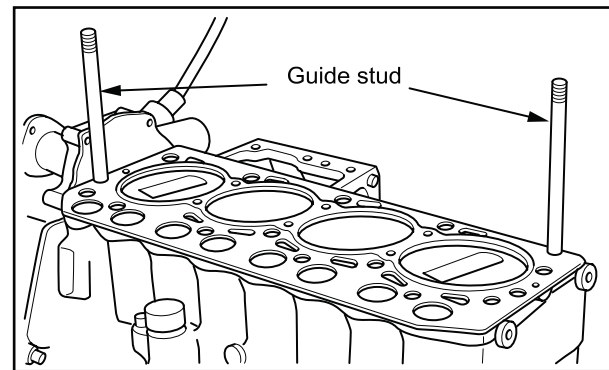

Installing cylinder head gasket

3.6 Installing cylinder head assembly

Align the cylinder head to the locating guide bolts, and install the cylinder head.

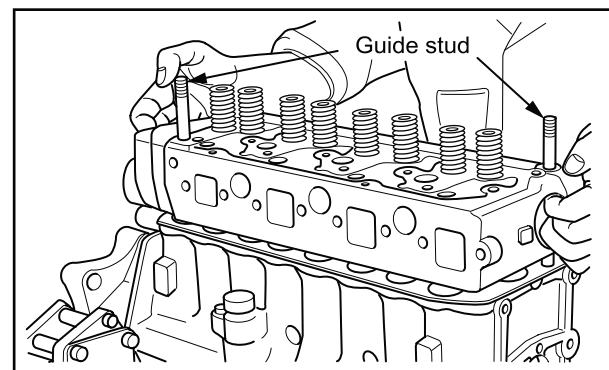

Installing cylinder head

3.7 Tightening cylinder head bolts

In the numerical order as shown in the illustration, tighten cylinder head bolts progressively to the specified torque.

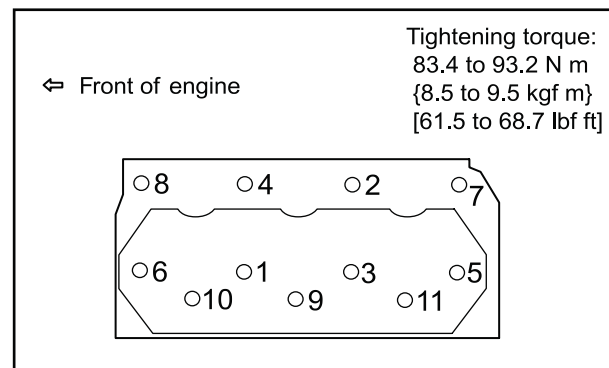

Tightening cylinder head bolts

3.8 Inserting push rod

- (1) Insert each push rod into its hole in the cylinder head.
- (2) Make sure that the ball end of each push rod is placed correctly on the tappet cup.

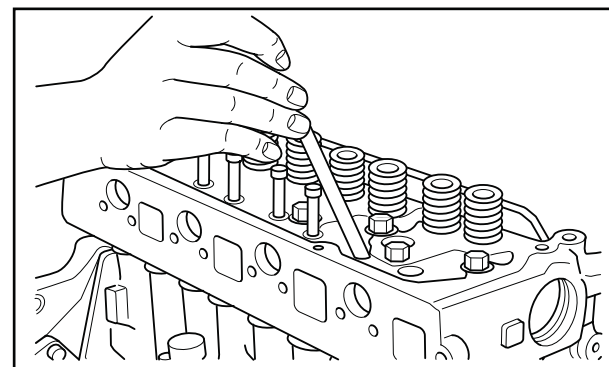

Inserting push rod

REASSEMBLY OF BASIC ENGINE

3.9 Reassembling rocker shaft assembly

- (1) Assemble the rocker shaft assembly in a correct order, and secure it with fixing bolt.
- (2) After reassembling, make sure that the rocker arms move lightly.

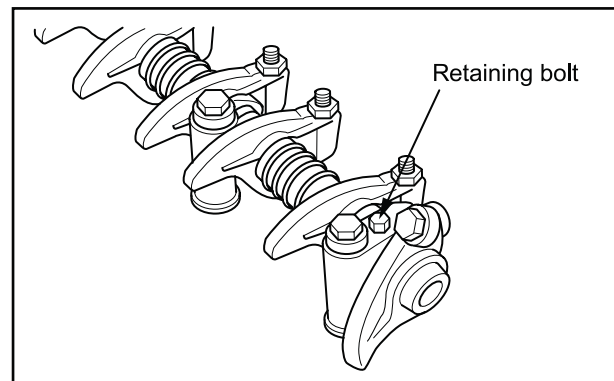

Reassembling rocker shaft assembly

3.10 Installing rocker shaft assembly

- (1) Install the valve caps to the valve heads.
- (2) Install the rocker shaft assembly to the cylinder head. Tighten the mounting bolts to the specified torque.

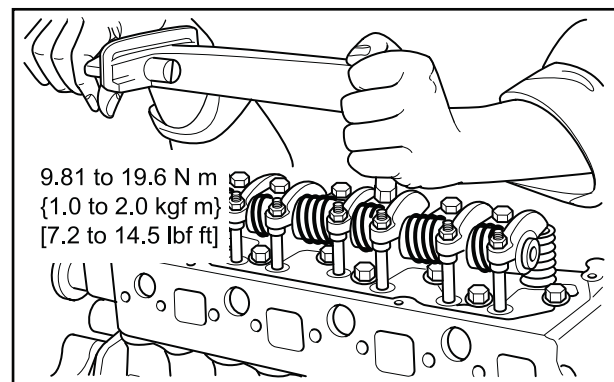

Installing rocker shaft assembly

3.11 Adjusting valve clearance

Adjust the valve clearance.

For adjusting procedures, refer to "Adjustment and Operation."

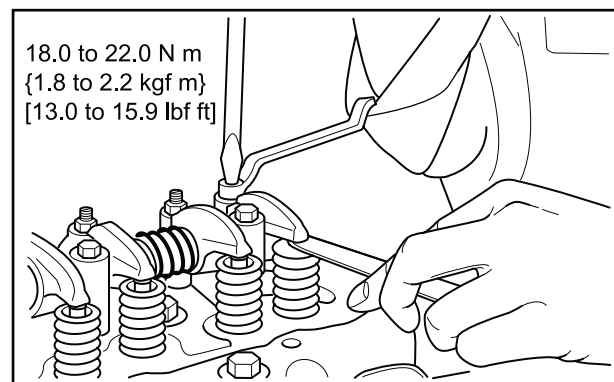

Adjusting valve clearance

3.12 Installing rocker cover

- (1) Make sure that the gasket is firmly installed into the rocker cover.
- (2) Tighten the rocker cover mounting nuts to the specified torque.

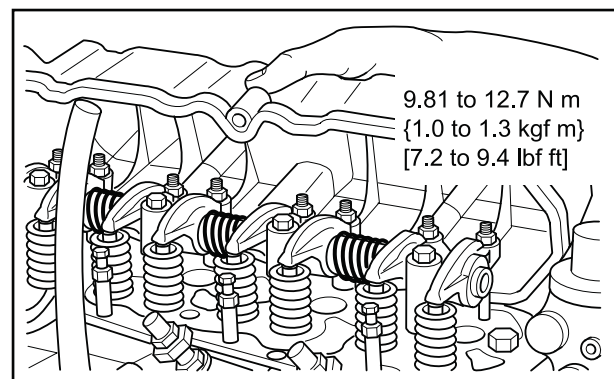

Installing rocker cover

FUEL SYSTEM

1. Removing fuel system	D-73
1.1 Removing fuel injection pipe	D-74
1.2 Removing fuel injection nozzle	D-74
1.3 Removing governor assembly	D-74
1.4 Removing governor weights	D-74
1.5 Removing fuel injection pump	D-75
2. Disassembling, inspecting and reassembling fuel system	D-76
2.1 Fuel injection nozzle	D-76
2.1.1 Disassembling and inspecting fuel injection nozzle	D-76
2.1.2 Inspecting and adjusting fuel injection valve opening pressure	D-77
2.1.3 Inspecting fuel spray pattern of fuel injection nozzle	D-77
2.1.4 Cleaning and replacing faulty nozzle	D-78
2.1.5 Reassembling fuel injection nozzle	D-78
2.2 Fuel injection pump	D-79
2.2.1 Inspecting fuel injection pump on engine	D-79
2.2.2 Disassembling and inspecting fuel injection pump	D-79
2.3 Governor	D-85
2.3.1 Disassembling and inspecting governor	D-85
2.4 Inspecting fuel pump	D-87
2.5 Fuel filter	D-88
2.5.1 Disassembling, inspecting and reassembling fuel filter	D-88
3. Installing fuel system	D-89
3.1 Installing fuel injection pump	D-90
3.2 Installing governor weights	D-90
3.3 Installing sliding sleeve	D-90
3.4 Installing governor assembly	D-91
3.5 Installing fuel injection nozzle	D-91
3.6 Installing fuel pipes	D-91

FUEL SYSTEM

1. Removing fuel system

CAUTION

Cover the openings on the injection pipe, nozzle inlet connector and injection pipe to prevent dust from entering the fuel system.

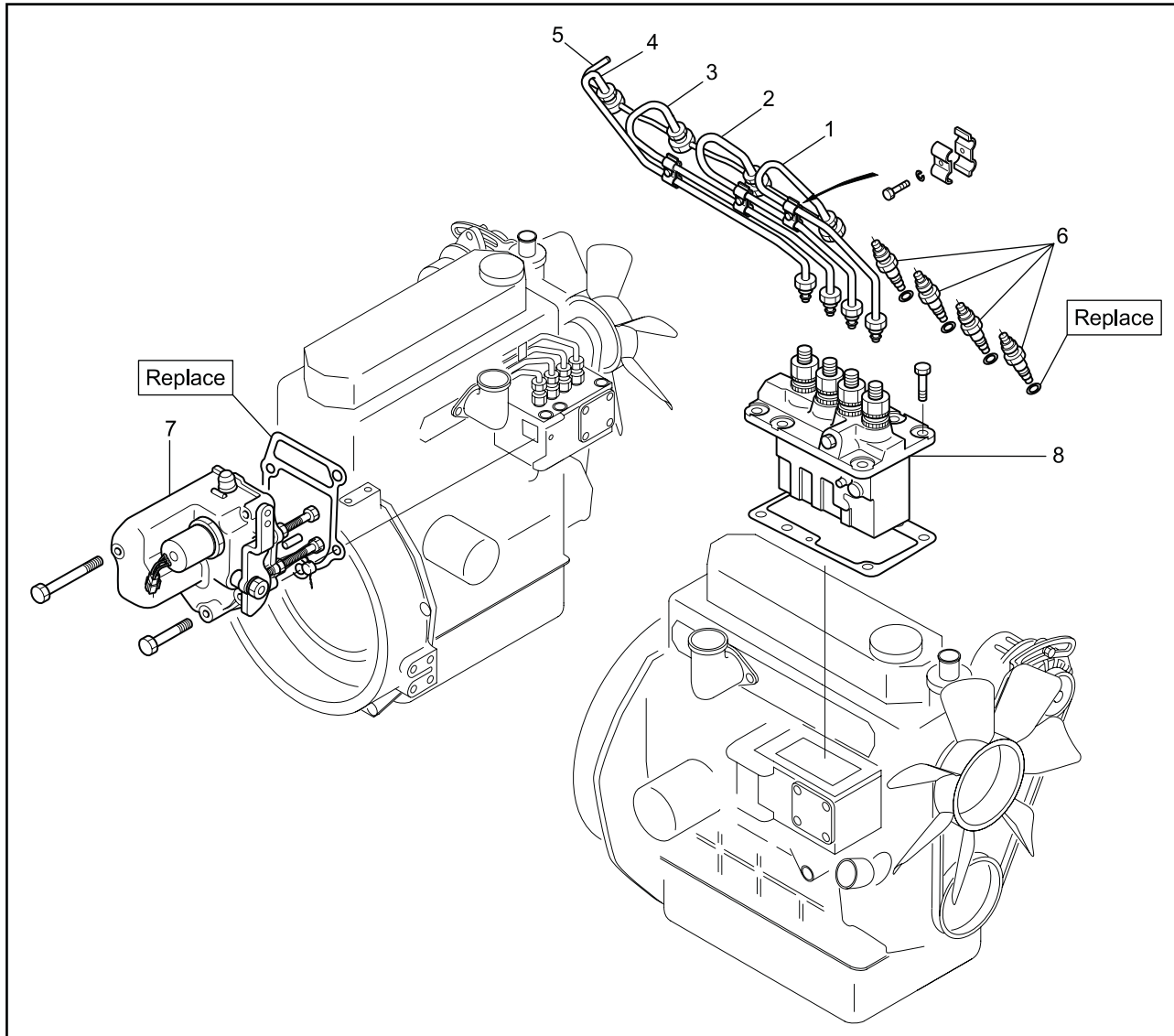

Removing fuel system

Removing sequence

- | | |
|-----------------------------|-------------------------|
| 1 No. 1 fuel injection pipe | 5 Fuel leak-off pipe |
| 2 No. 2 fuel injection pipe | 6 Fuel injection nozzle |
| 3 No. 3 fuel injection pipe | 7 Governor |
| | 8 Fuel injection pump |

Note: Some Illustrations are for reference purposes. Actual design may vary as per model.

FUEL SYSTEM

1.1 Removing fuel injection pipe

Remove the fuel injection pipe and fuel leak-off pipe.

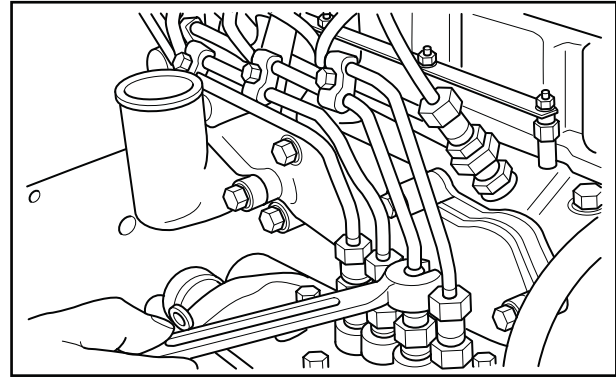

Removing fuel injection pipe

1.2 Removing fuel injection nozzle

Using a wrench, loosen the nozzle, and remove the fuel injection nozzle and holder gasket.

Note: Using a wire or screwdriver remove the holder gasket.

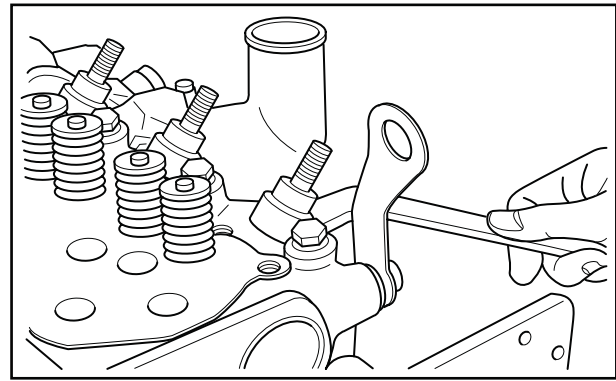

Removing fuel injection nozzle

1.3 Removing governor assembly

- (1) Remove the tie-rod cover.
- (2) Using a pair of cutting pliers, remove the tie-rod spring. Disconnect the tie-rod from the fuel injection pump.
- (3) Remove the governor assembly.

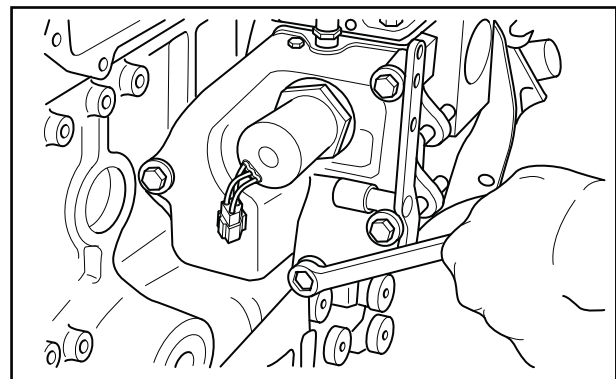

Removing governor assembly

1.4 Removing governor weights

- (1) Remove the sliding sleeve.
- (2) Remove the sliding sleeve shaft and then the governor weights.

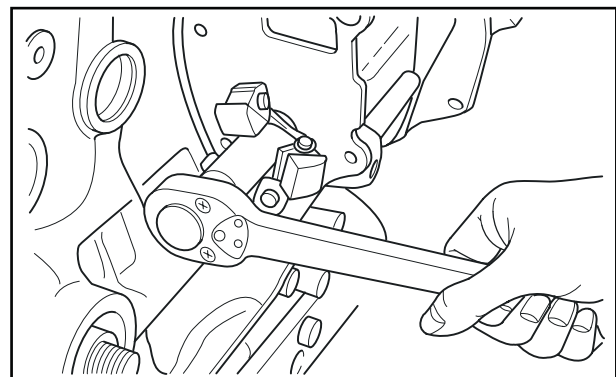

Removing governor weights

FUEL SYSTEM

1.5 Removing fuel injection pump

- (1) Remove the tie-rod cover.
- (2) Using a pair of cutting pliers, remove the tie-rod spring. Disconnect the tie-rod from the fuel injection pump.

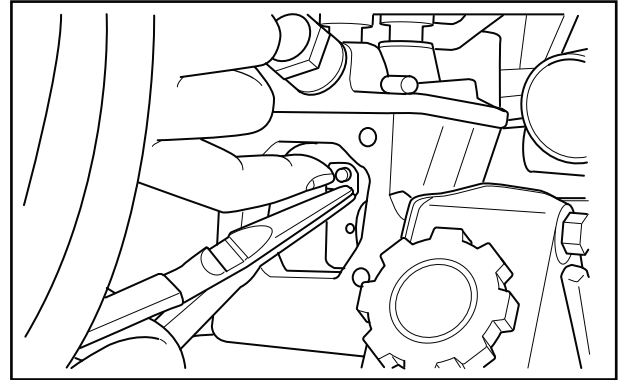

Removing tie rod

- (3) Remove the fuel injection pump.

Note: Note the thickness of shim pack for the adjustment of the fuel injection timing.

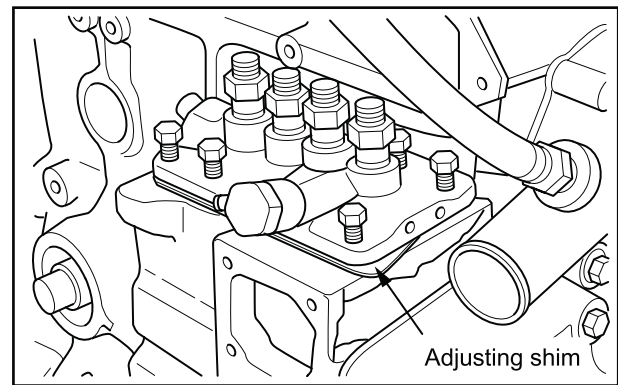

Removing fuel injection pump

FUEL SYSTEM

2. Disassembling, inspecting and reassembling fuel system

2.1 Fuel injection nozzle

2.1.1 Disassembling and inspecting fuel injection nozzle

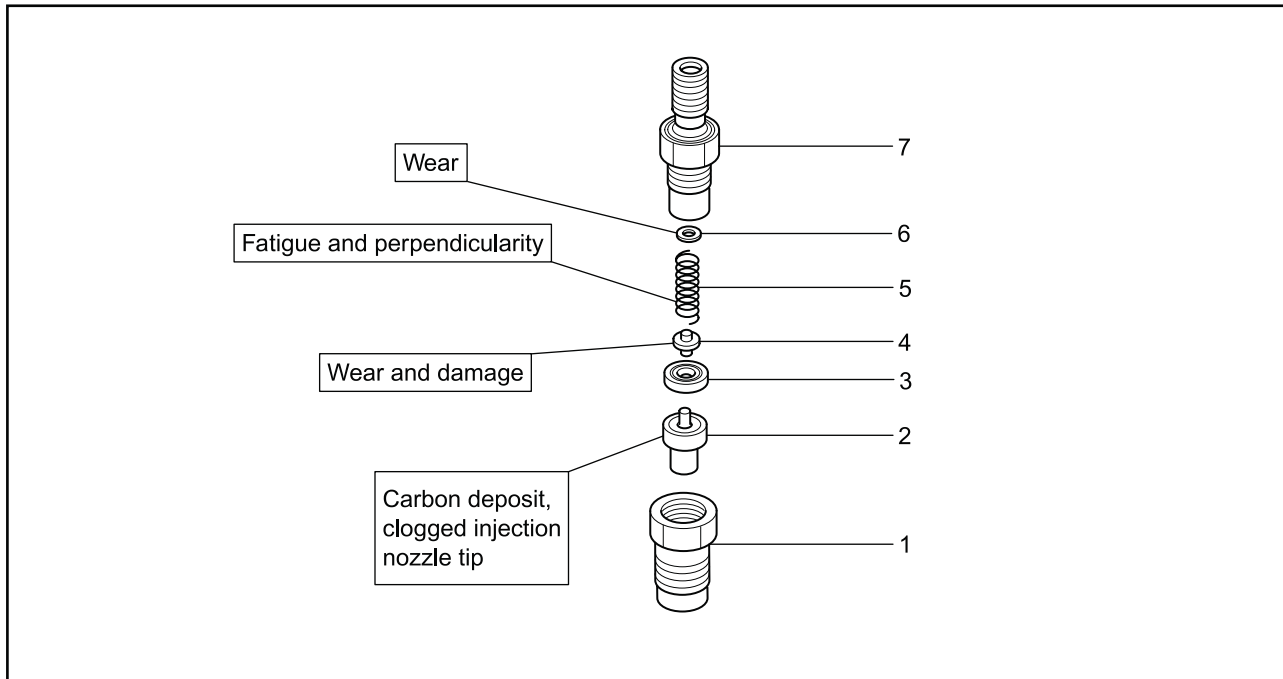

Disassembling and inspecting fuel injection nozzle

Disassembling sequence

- | | | |
|------------------------|----------|-----------------|
| 1 Nozzle retaining nut | 4 Pin | 7 Nozzle holder |
| 2 Nozzle tip assembly | 5 Spring | |
| 3 Piece | 6 Washer | |

FUEL SYSTEM

2.1.2 Inspecting and adjusting fuel injection valve opening pressure

CAUTION

Never touch the injection nozzle tip during nozzle injection test.

- (1) Mount the nozzle on the nozzle tester.
- (2) Push down the handle at a speed of once a second and read the pressure when injection starts. Make adjustment if it is outside the standard.
- (3) To adjust the injection start pressure, remove the set screw on the nozzle holder, loosen the cap nut and turn the adjusting screw with a driver.
- (4) After adjustment, tighten the cap nut and set screw with the specified torque.
- (5) After tightening the set screw, check if the injection start pressure is within the standard again.

Item	Nominal	Standard
Valve opening pressure	13.73 MPa {140 kgf/cm ² } [1991 psi]	14.22 to 15.00 MPa {145 to 153 kgf/cm ² } [2062 to 2176 psi] (New parts value)

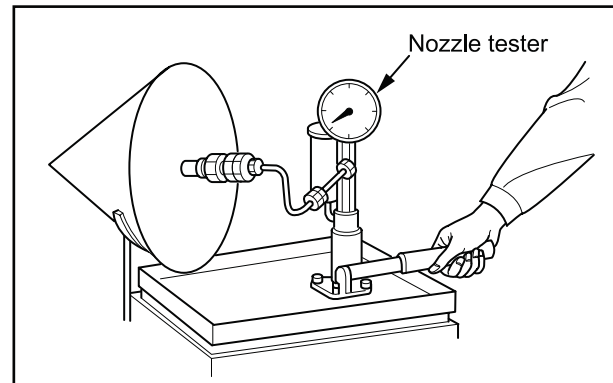

Inspecting fuel injection valve opening pressure

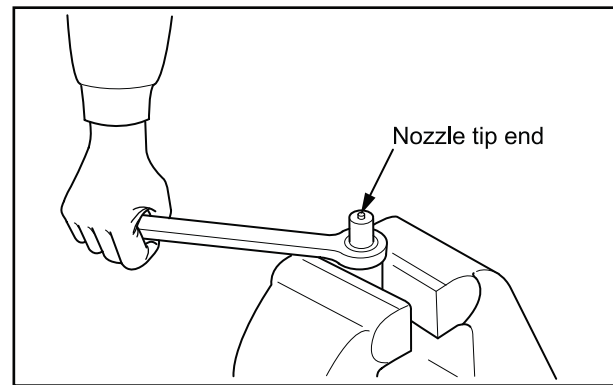

Replacing fuel injection nozzle tips

2.1.3 Inspecting fuel spray pattern of fuel injection nozzle

- (1) When adjusting the nozzle opening pressure using the nozzle tester, check for nozzle hole condition, and fuel spray pattern.
- (2) Checking points of fuel spray are as follows:
 - Fuel is injected from all spray holes simultaneously.
 - Fuel is injected conically at the specified spray angle.
 - Fuel is injected in a spray of fine droplets.
 - Fuel is injected without after-dribbling.
- (3) If spray condition is faulty, clean or replace the nozzle tip.

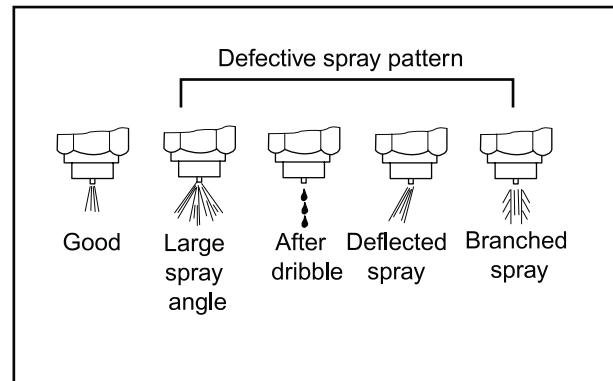

Inspecting fuel spray pattern from fuel injection nozzle

FUEL SYSTEM

2.1.4 Cleaning and replacing faulty nozzle

CAUTION

When pulling out the nozzle tip, be careful not to damage the tip.

- (1) Loosen the retaining nut, then remove the nozzle tip, and clean the needle valve and body.
- (2) Clean the nozzle tip in clean wash oil. After cleaning, assemble the needle valve and body in clean diesel fuel.
Note: The needle valve and body are precision parts. Handle them carefully, and do not change the combination of the valve and body.
- (3) Tighten the nozzle tip retaining nut to the specified torque.
- (4) If the spray pattern is still faulty after cleaning and adjusting, replace the nozzle tip.

Note: When using a new nozzle tip, remove the anti-corrosive agent from the nozzle tip, and clean the nozzle tip in wash oil. Then clean the tip again in the fuel before assembly.

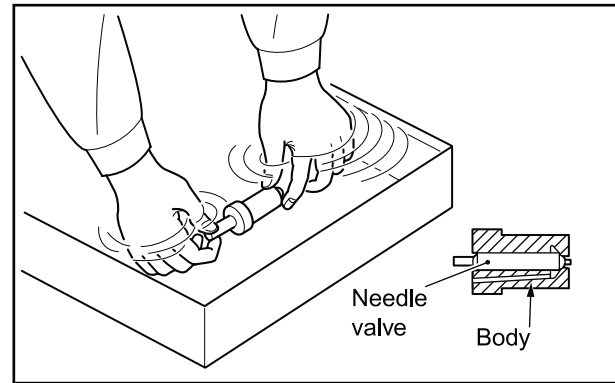

Cleaning nozzle tip assembly

2.1.5 Reassembling fuel injection nozzle

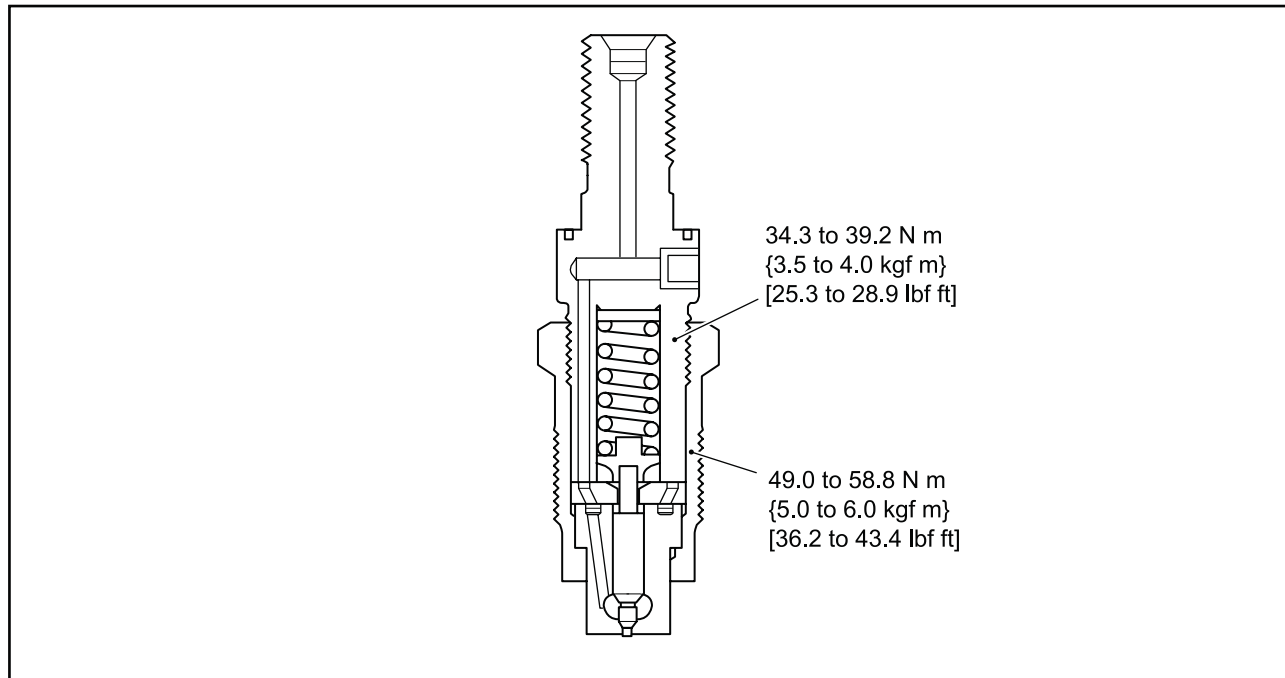

Reassembling fuel injection nozzle

FUEL SYSTEM

2.2 Fuel injection pump

2.2.1 Inspecting fuel injection pump on engine

Do not disassemble the fuel injection pump unless it is absolutely necessary.

If faulty, it is desirable to replace it as an assembly.

Inspection item	Inspection procedure	Judgment
Low idling	Judgment by rotation speed	(Varies depending on specification)
Exhaust color	Observe exhaust color during sudden acceleration under no load. Observe exhaust color under load.	No remarkable black smoke is emitted.
Nozzle injection condition	Remove the nozzle and reassemble them so that spray holes face outward. Rotate the starter to carefully observe the spray pattern.	The spray pattern must be good.

2.2.2 Disassembling and inspecting fuel injection pump

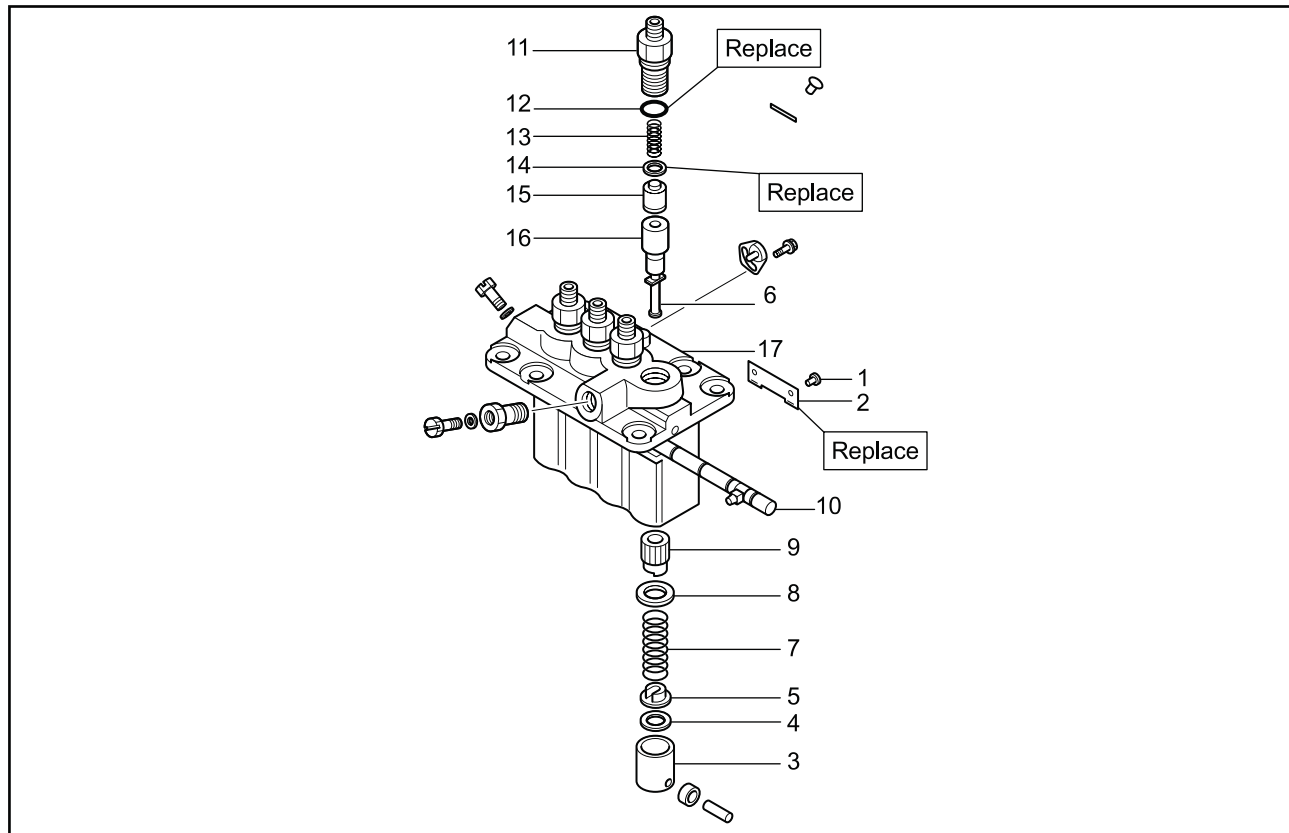

Disassembling and inspecting fuel injection pump

Disassembling sequence

- | | | |
|-------------------------|--------------------------|--------------------------|
| 1 Tappet guide pin | 7 Plunger spring | 13 Delivery valve spring |
| 2 Lock plate | 8 Spring upper seat | 14 Delivery valve gasket |
| 3 Tappet | 9 Control sleeve | 15 Delivery valve |
| 4 Tappet adjusting shim | 10 Control rack | 16 Plunger barrel |
| 5 Spring lower seat | 11 Delivery valve holder | 17 Pump housing |
| 6 Plunger | 12 O-ring | |

FUEL SYSTEM

2.2.3 Removing tappet

CAUTION

Once the tappet guide pin is removed, the tappet will spring out. Do not allow it to drop on the floor.

- (1) Unbend the lock plate's lug using a screw driver.
- (2) Rotate the tappet guide pin 180° to align the guide pin's flat edge with the counterpart in the housing.
- (3) While pushing in the tappet, pull out the tappet guide pin with long-nose pliers.

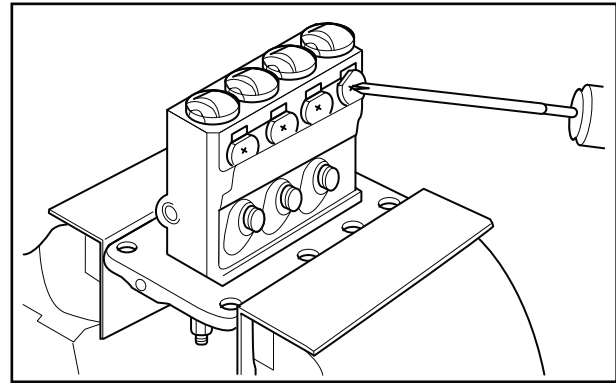

Removing tappet guide pin

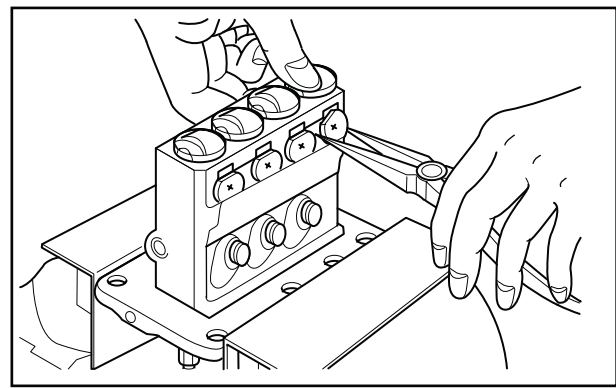

Removing tappet

2.2.4 Removing plunger

- (1) Remove the tappet adjusting shim.
- (2) Using tweezers, remove the plunger together with the spring lower seat.
- (3) Remove the plunger spring.
- (4) Remove the control sleeve together with the spring upper seat.
- (5) Pull out the control rack.

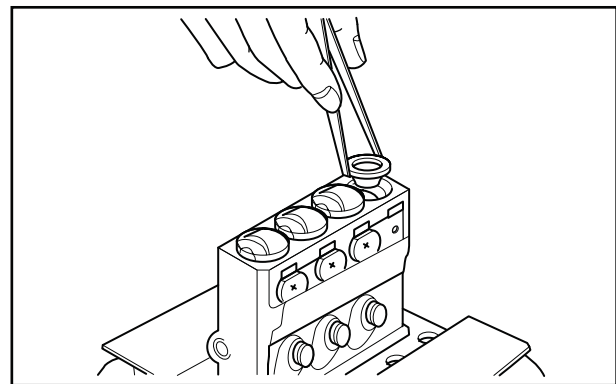

Removing plunger

FUEL SYSTEM

2.2.5 Removing delivery valve

CAUTION

- (a) The delivery valve, plunger and plunger barrel are precision-machined parts. Do not smear or scratch them.
- (b) Keep the combination of the plunger barrel and plunger for each cylinder when removing. Do not mix the plunger barrel with the plunger of a different cylinder.

- (1) With pump housing faced up, grab the housing with a vise.
- (2) Remove the delivery valve holder.
- (3) Remove the delivery valve gasket.
- (4) Using a pair of tweezers, remove the delivery valve.

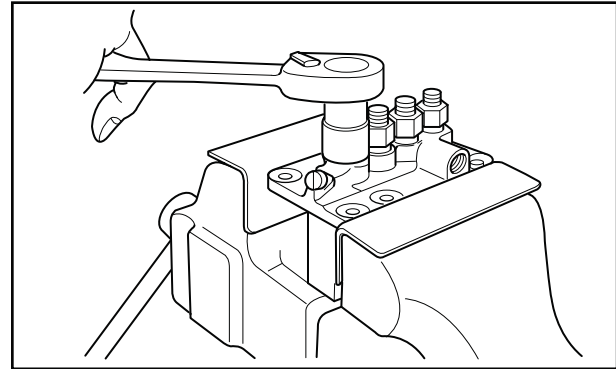

Removing delivery valve holder

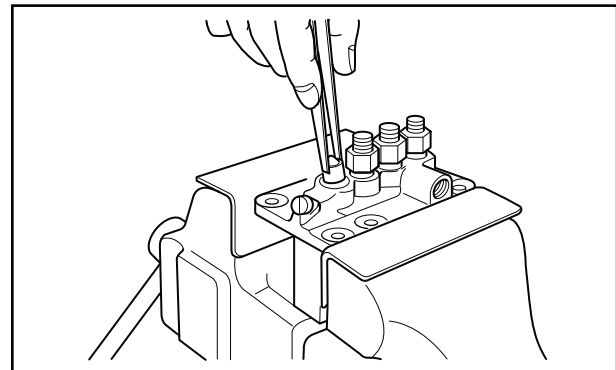

Removing delivery valve

2.2.6 Removing plunger barrels

CAUTION

- (a) Plungers and plunger barrels are precision-machined parts. Do not smear or scratch them.
- (b) Keep the combination of the plunger barrel and plunger for each cylinder when removing. Do not mix the plunger barrel with the plunger of a different cylinder.

Remove the plunger barrels.

Note: (a) When replacing plunger barrels or delivery valves, do not loosen the adjusting plates between the cylinders.

- (b) Replacement of any of those parts requires a subsequent measurement of injection rate using a pump test cam box.
- (c) Parts that have been disassembled should be kept in a container filled with a clean light oil.

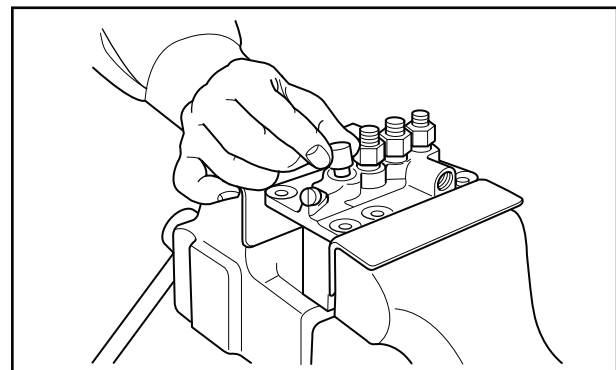

Removing plunger barrel

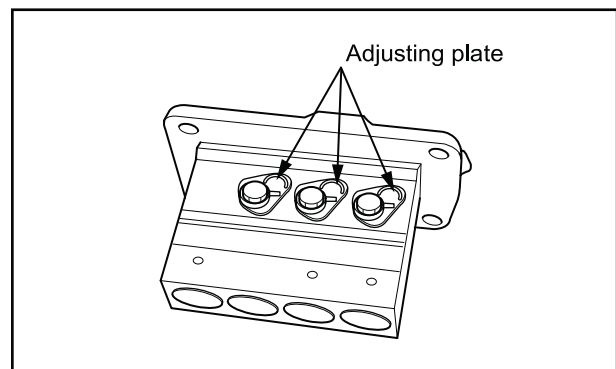

Do not loosen adjusting plate

FUEL SYSTEM

2.2.7 Reassembling fuel injection pump

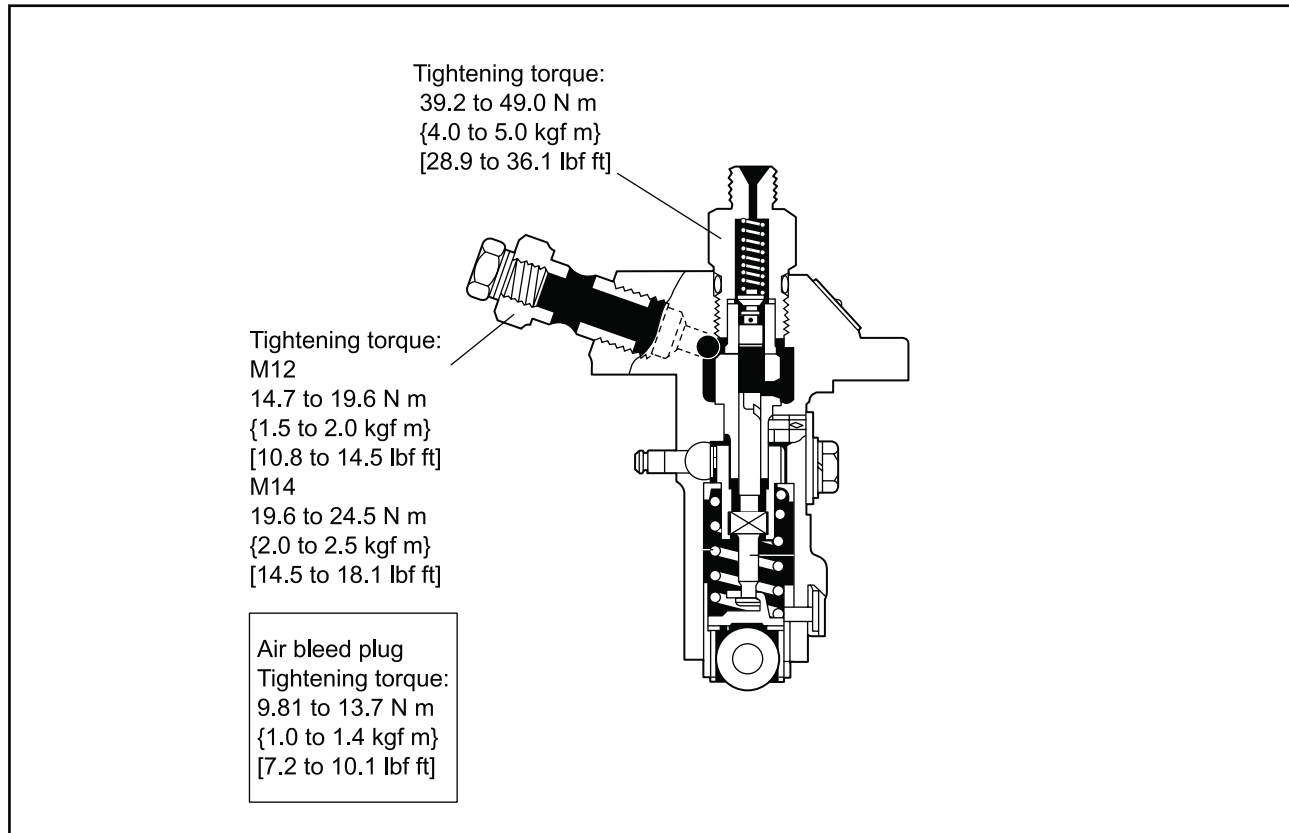

Reassembling fuel injection pump

2.2.8 Installing plunger barrel

Align the plunger barrel groove with the knock pin of the pump housing, and insert the plunger barrel into the pump housing.

Note: If the knock pin is not aligned with the plunger barrel groove, the plunger barrel will not be installed correctly. Make sure that O-ring is not protruded from the pump housing when the delivery valve holder is snugly tightened.

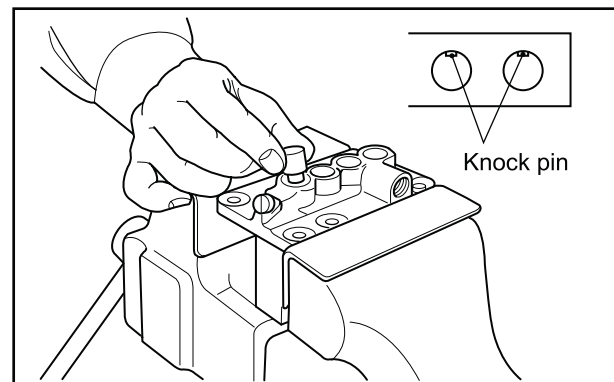

Installing plunger barrel

FUEL SYSTEM

2.2.9 Assembling delivery valve

CAUTION

- (a) Do not reuse the O-ring.
- (b) Install a new O-ring so that it is not cut with threads of the valve holder.

Assemble the delivery valve, delivery valve gasket and delivery valve spring. Then with the O-ring installed, temporarily tighten the delivery valve holder.

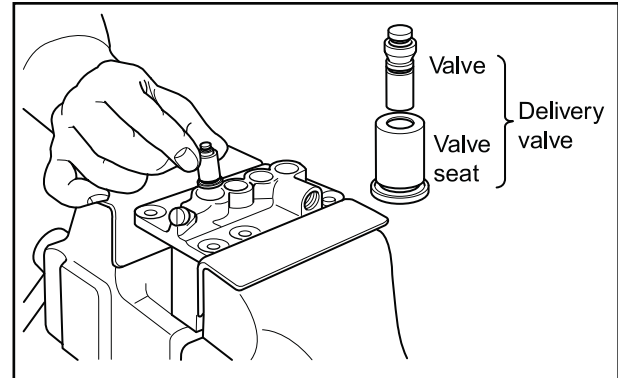

Assembling delivery valve

2.2.10 Assembling control sleeve

CAUTION

Assemble the plunger with its slit side faced to the adjusting plate mounting side.

- (1) Assemble the control sleeves and the control rack so that the central tooth of each sleeve is aligned with the corresponding notch on the rack.
- (2) Insert the plunger into the hole in the sleeve.

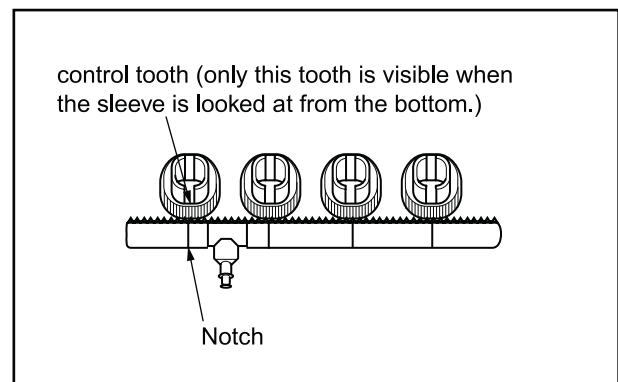

Assembling control sleeve

2.2.11 Assembling tappet

CAUTION

Always use new lock plate. Never reuse the lock plate that has been removed.

With the tappet pushed in, move the control rack. When the tappet's groove and the tappet guide pin hole in the pump housing are aligned, install the lock plate and the pin.

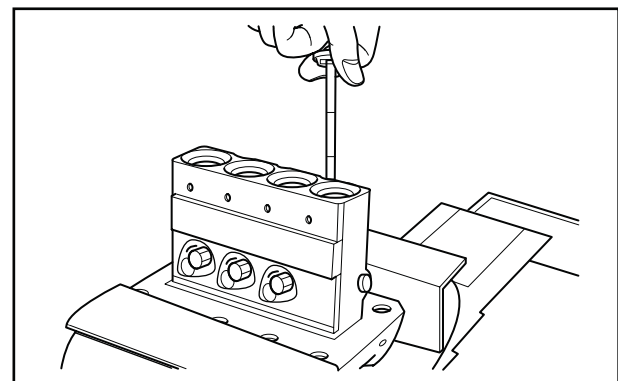

Installing plunger

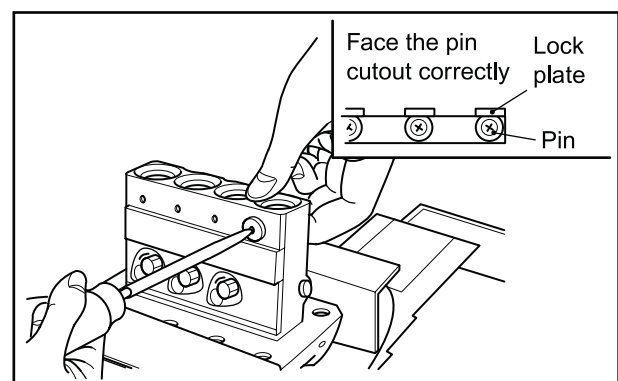

Assembling tappet

FUEL SYSTEM

2.2.12 Tightening delivery valve holder

- (1) Place the pump housing upright, and grab the housing with a vise.
- (2) Tighten the delivery valve holder to the specified torque.

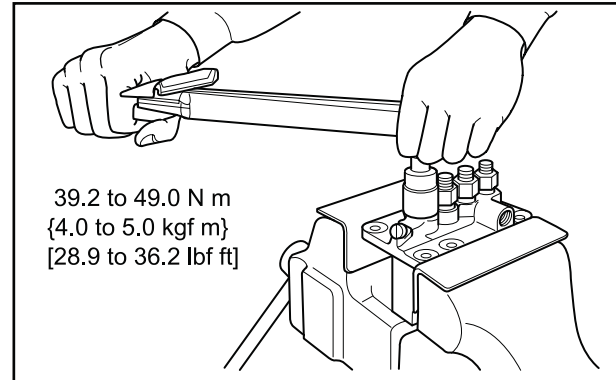

Tightening delivery valve holder

2.2.13 Inspecting control rack for smooth operation

- (1) Remove the pump housing from the vise and check the control rack for smooth movement.
If the movement is not smooth, the following defects are suspected:
 - Sliding of the element is poor.
 - A foreign substance is present in the teeth of rack or sleeve.
 - The valve holder is overtightened.
- (2) Check the injection timing.

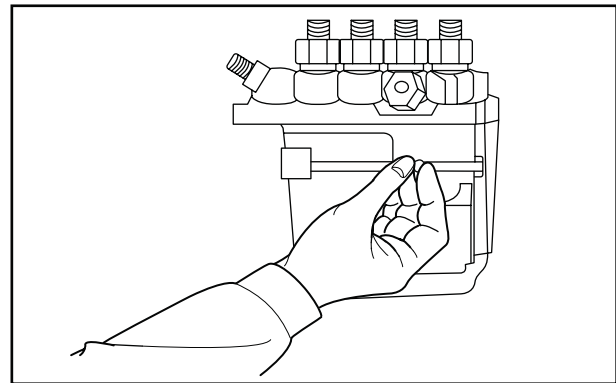

Inspecting control rack for smooth operation

FUEL SYSTEM

2.3 Governor

2.3.1 Disassembling and inspecting governor

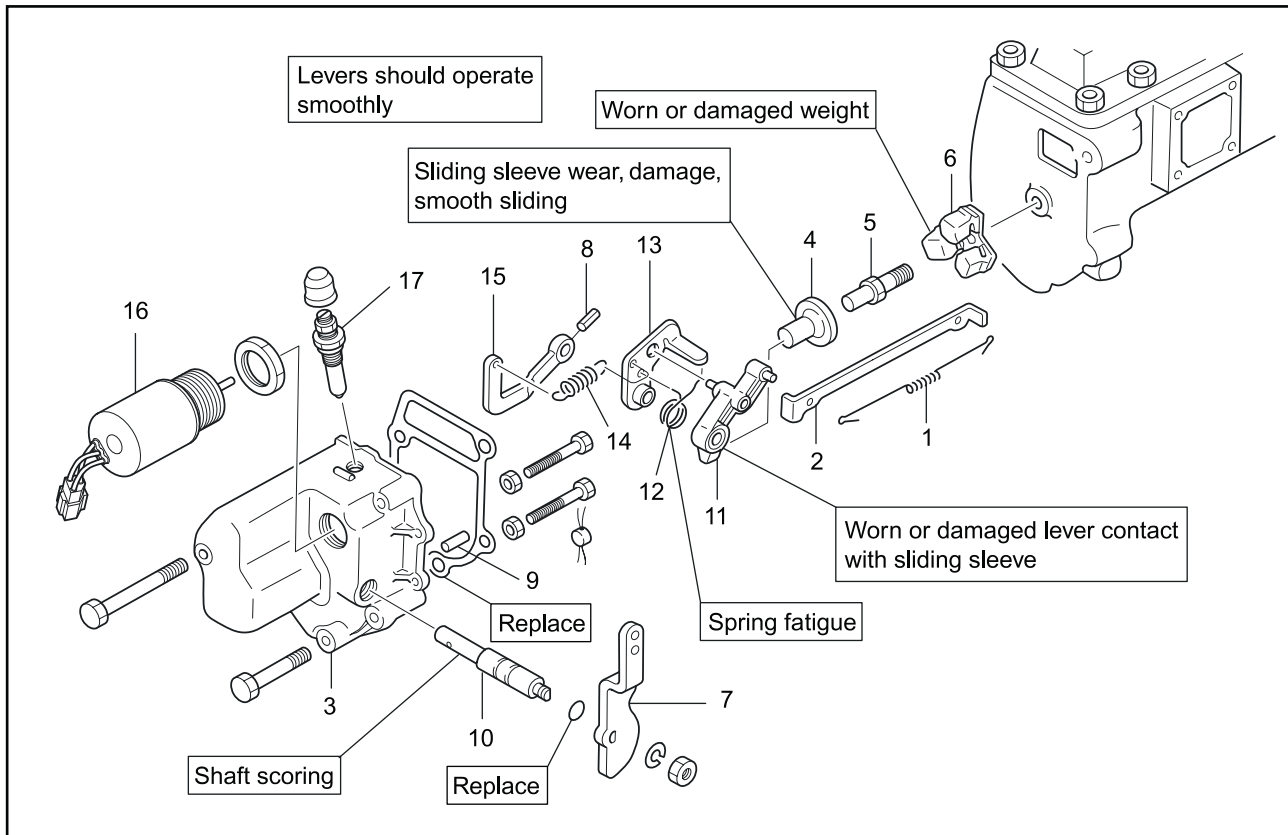

Disassembling and inspecting governor

Disassembling sequence

- | | | |
|------------------------|-----------------------|--|
| 1 Tie rod spring | 7 Speed control lever | 13 Tension lever |
| 2 Tie rod | 8 Spring pin | 14 Governor spring |
| 3 Governor case | 9 Grooved pin | 15 Governor spring lever
(Remove 11 to 15 as an assembly) |
| 4 Sliding sleeve | 10 Governor shaft | 16 Stop solenoid |
| 5 Sliding sleeve shaft | 11 Governor lever | 17 Rack set screw |
| 6 Governor weight | 12 Start spring | |

FUEL SYSTEM

2.3.2 Reassembling the governor

(1) Install the levers first.

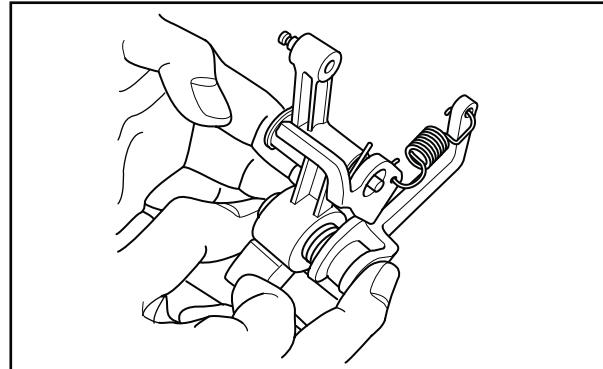

Reassembling lever

(2) Install the O-ring onto the governor shaft.

(3) Insert the governor shaft into the governor case, and combine it with the levers.

(4) Hold the grooved pin and the spring pin in place, and knock them in with a soft hammer.

(5) Install the tie-rod and the tie-rod spring.

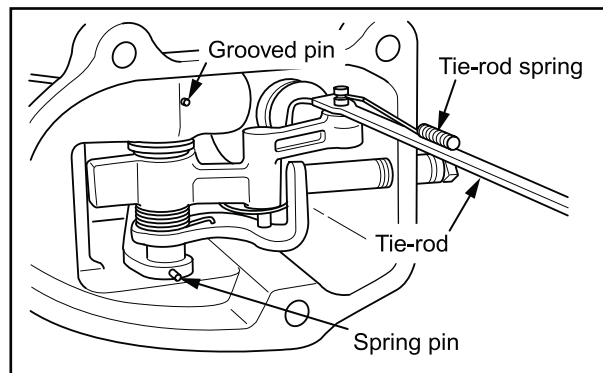

Reassembling governor

2.3.3 Installing torque spring set

Prior to installation, adjust the low and high idle speeds of engine. Stop the engine for installation and adjustment of the torque spring set.

(1) remove the tie-rod cover.

(2) Pull the speed control lever to the high idle speed position and hold it.

(3) Pull the tie-rod in the direction of the arrow until a slight resistance is felt.

Note: This is the initial resistance by the governor spring.

Do not pull the tie-rod further to try to overcome the resistance.

(4) While holding the tie-rod in this position, screw in the torque spring set until the notched line on the control rack is aligned with that on the pump body.

(5) With the both notched lines aligned, lock the torque spring set by tightening the special nut to the specified torque.

(6) Place the torque set sealing cap over the torque spring set, and stake it in place.

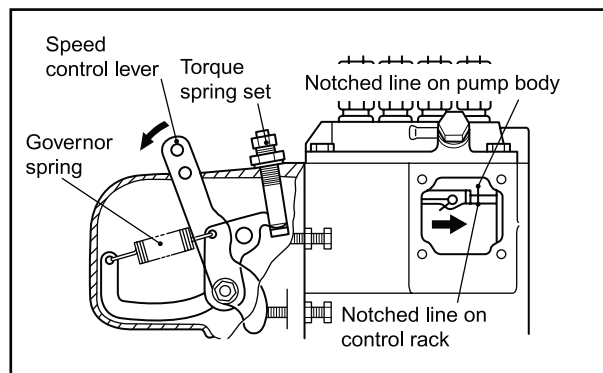

Installing torque spring set

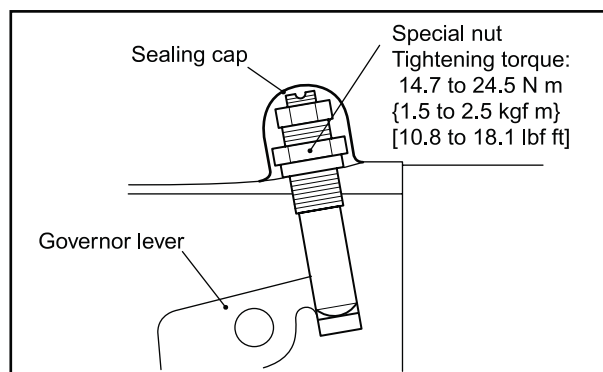

Adjusting and sealing torque spring set

FUEL SYSTEM

2.4 Inspecting fuel pump

The fuel pump is available in 3 types and the type differs based on engine specifications.

(1) Electromagnetic plunger-type fuel pump

For this pump, a large-sized pump of normal type with a filter element and a small-sized pump of compact type without a filter element are available. In either type, apply the specified voltage, and check for operation and fuel leakage.

For the type with filter element, remove the cover and clean or replace the filter element.

Check for external damage,
fuel leakage

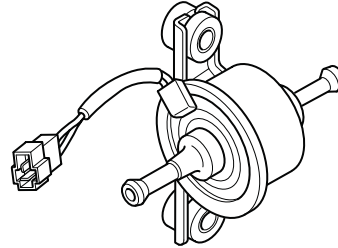

Plunger fuel pump (compact-size version)

FUEL SYSTEM

2.5 Fuel filter

2.5.1 Disassembling, inspecting and reassembling fuel filter

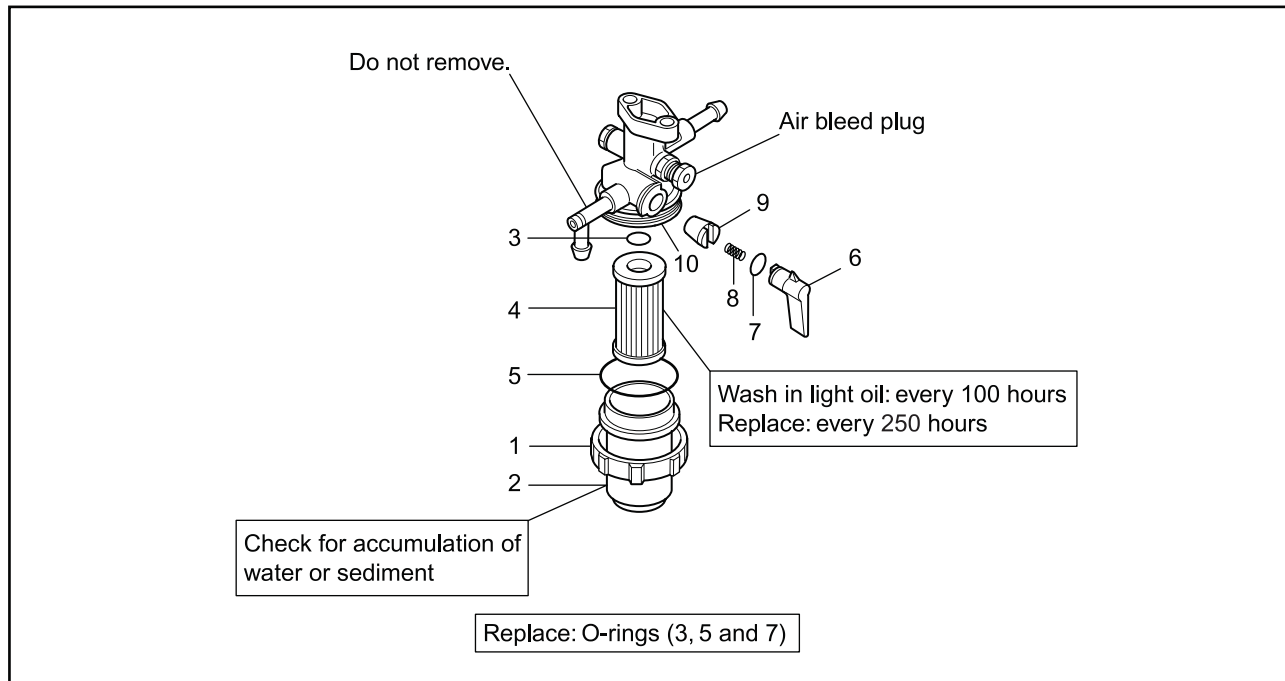

Disassembling, inspecting and reassembling fuel filter

Disassembling sequence

1 Ring nut	4 Element	7 O-rings	10 Filter body
2 Cup	5 O-rings	8 Spring	
3 O-rings	6 Cock lever	9 Valve	

Note: (a) Disassemble the fuel filter only when removing the element. Do not disassemble the cock lever unless absolutely necessary.

(b) When removing the cock lever and reassembling it after cleaning, apply silicon oil to the O-ring of the lever.

When dust or water is accumulated at the case bottom or in the element, replace the filter as an assembly. Replace the fuel filter every 250 hours. Check the filter every 100 hours. If defective, replace the filter regardless of the replacement interval.

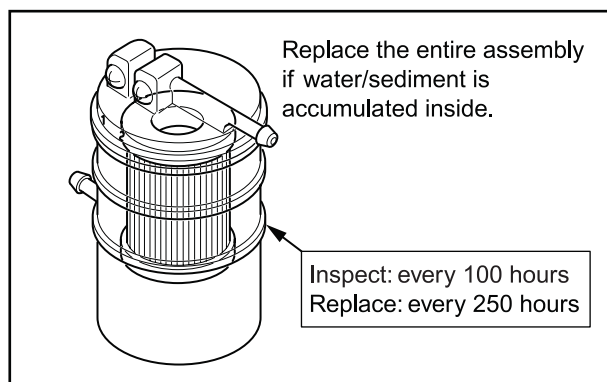

Inspecting fuel filter (cartridge type)

FUEL SYSTEM

3. Installing fuel system

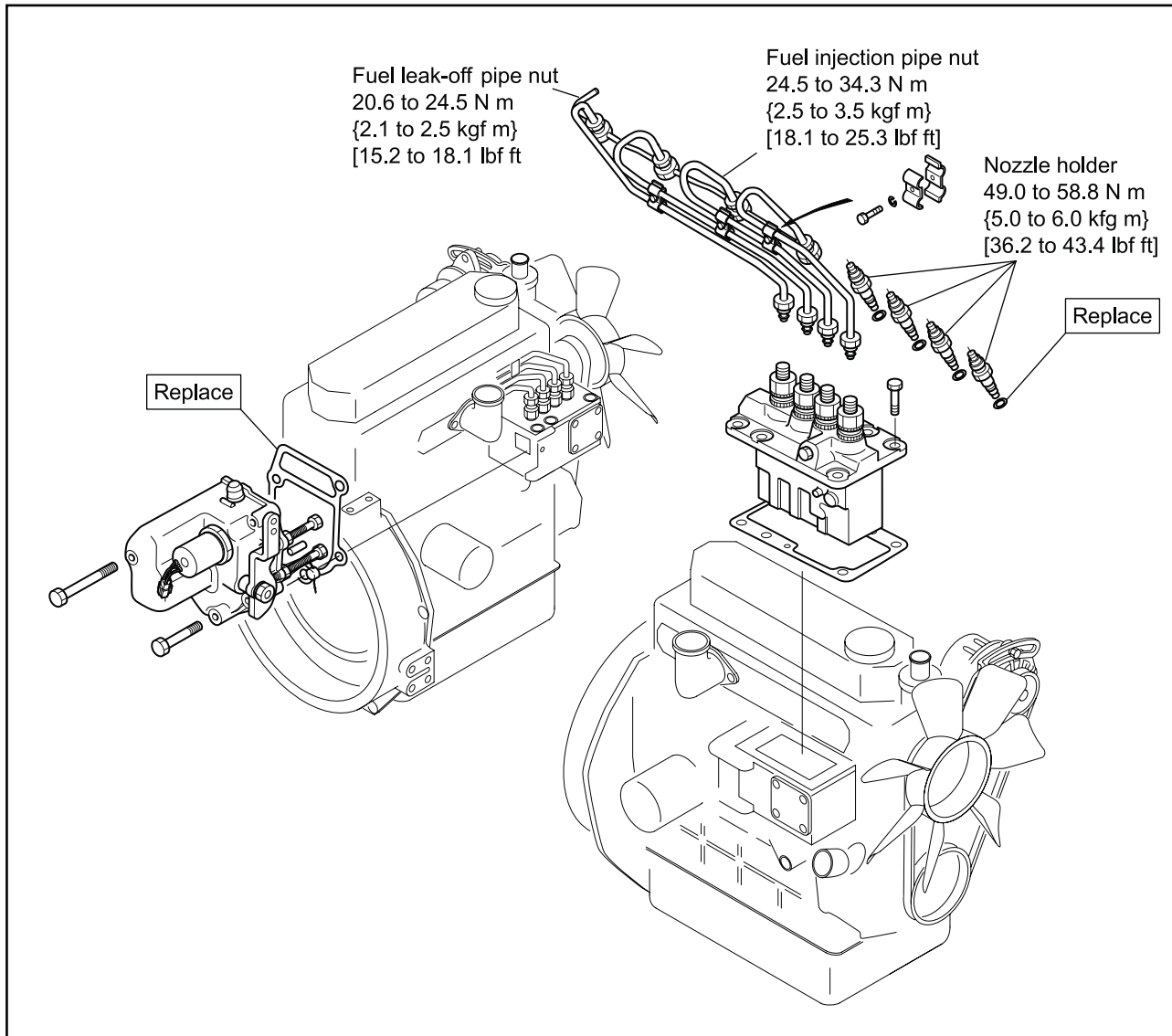

Installing fuel system

FUEL SYSTEM

3.1 Installing fuel injection pump

- (1) Install the fuel injection pump housing complete with the pumps onto the cylinder block, and tighten the retaining bolts.

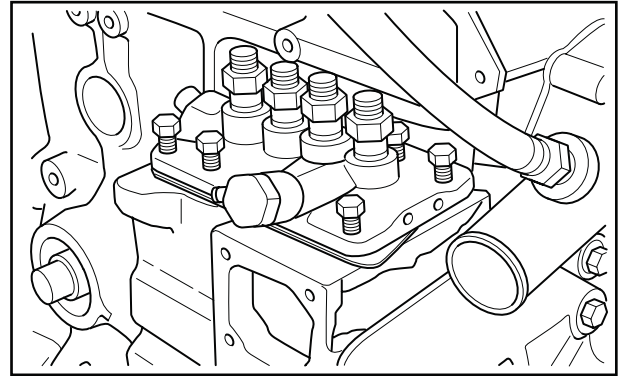

Installing fuel injection pump

- (2) Install the governor assembly, inserting the tie-rod and the tie-rod spring into the fuel injection pump housing.

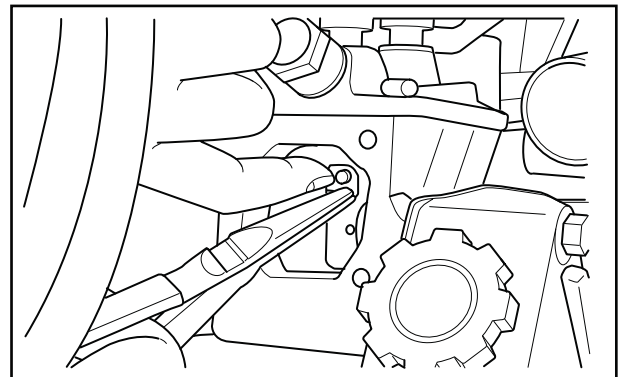

Removing tie rod

3.2 Installing governor weights

Install the governor weights onto the rear end of the pump camshaft and tighten the sliding sleeve shaft to the specified torque.

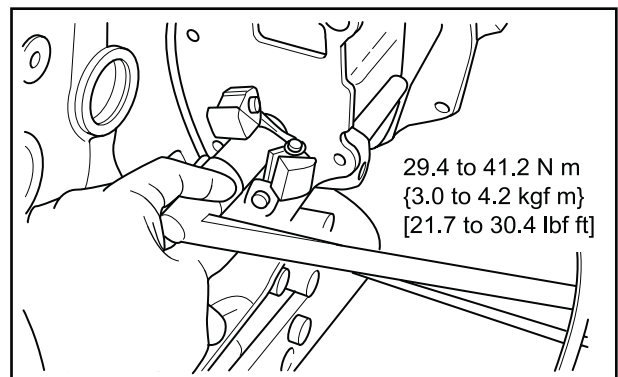

Installing governor weights

3.3 Installing sliding sleeve

Install the sliding sleeve onto the sliding sleeve shaft. Ensure that the sleeve slides smoothly.

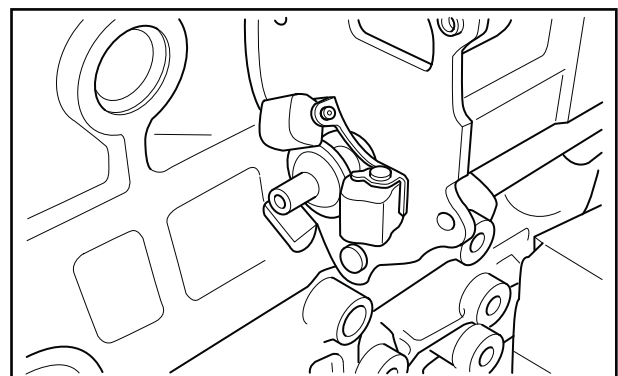

Installing slideing sleeve

FUEL SYSTEM

3.4 Installing governor assembly

- (1) Install the governor assembly onto the pump housing.
- (2) Connect the tie-rod and the tie-rod spring to the pumps.
- (3) Install the tie-rod cover.

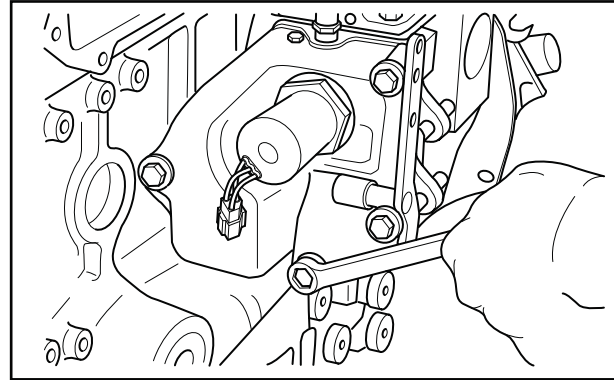

Removing governor assembly

3.5 Installing fuel injection nozzle

- (1) Clean the nozzle holder hole of cylinder head.
- (2) Install the gasket to the nozzle tip and tighten the fuel injection nozzle.

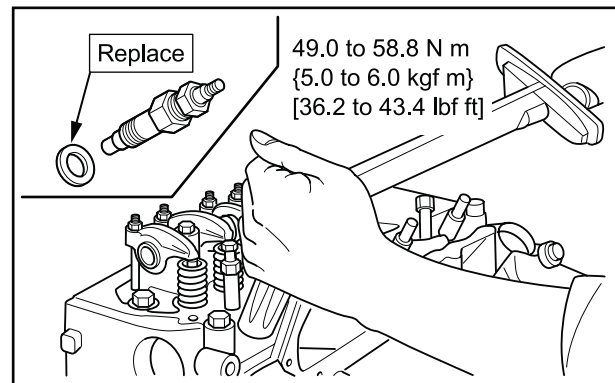

Installing fuel injection nozzle

3.6 Installing fuel pipes

- (1) Install the fuel leak-off pipe onto the fuel injection nozzles.
- (2) Install the fuel injection pipes, and hold them in place with clamps.
- (3) Tighten the fuel leak-off and fuel injection pipe nuts to the specified torques.

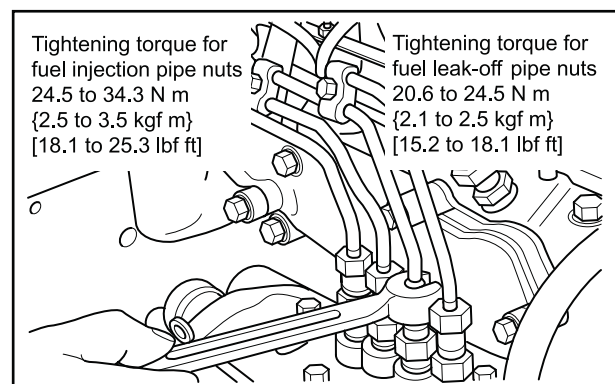

Installing fuel pipe

LUBRICATION SYSTEM

1. Removing lubrication system	D-93
1.1 Removing oil filter	D-94
1.2 Removing relief valve	D-94
1.3 Removing oil pressure switch	D-94
2. Disassembling, inspecting and reassembling lubrication system	D-95
2.1 Inspecting the oil pump	D-95
2.2 Inspecting relief valve	D-95
2.3 Inspecting oil pressure switch	D-96
3. Installing lubrication system	D-97
3.1 Installing oil pressure switch	D-98
3.2 Installing relief valve	D-98
3.3 Installing oil filter	D-98

LUBRICATION SYSTEM

1. Removing lubrication system

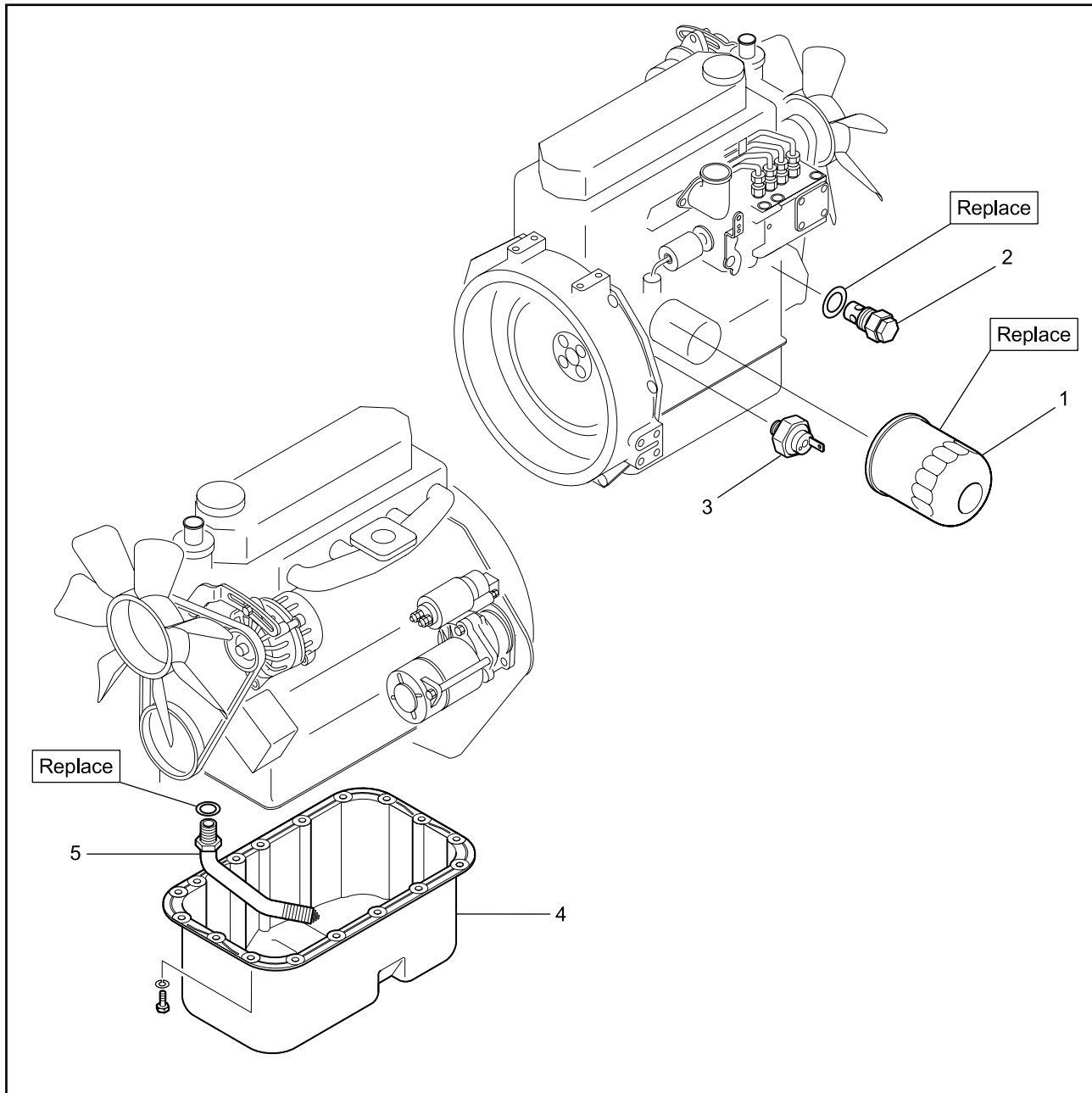

Removing lubrication system

Removing sequence

- | | | |
|----------------|-----------------------|----------------|
| 1 Oil filter | 3 Oil pressure switch | 5 Oil strainer |
| 2 Relief valve | 4 Oil pan | |

LUBRICATION SYSTEM

1.1 Removing oil filter

- (1) Place a drip pan under the oil filter.
- (2) Remove the oil filter using a filter wrench.

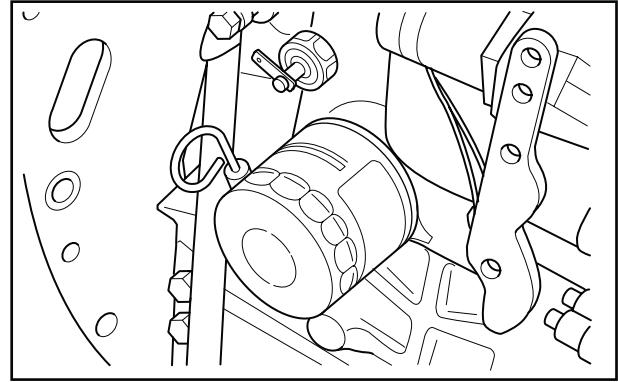

Removing oil filter

1.2 Removing relief valve

Remove the relief valve.

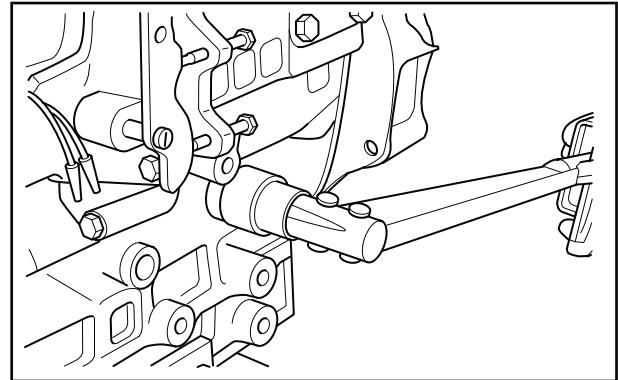

Removing relief valve

1.3 Removing oil pressure switch

Using an oil pressure switch socket wrench, remove oil pressure switch.

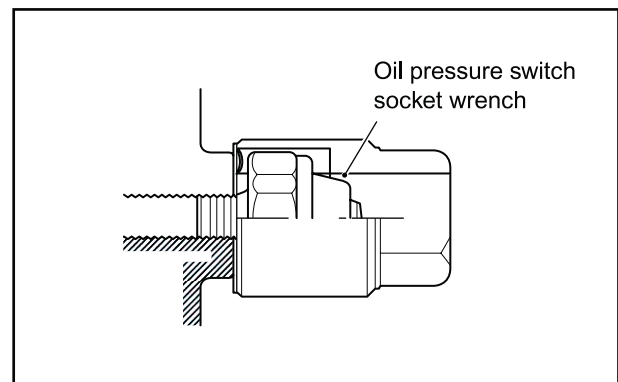

Removing oil pressure switch

LUBRICATION SYSTEM

2. Disassembling, inspecting and reassembling lubrication system

2.1 Inspecting the oil pump

Check the oil pump for any damage, and whether or not it rotates smoothly. If faulty, replace the entire pump assembly.

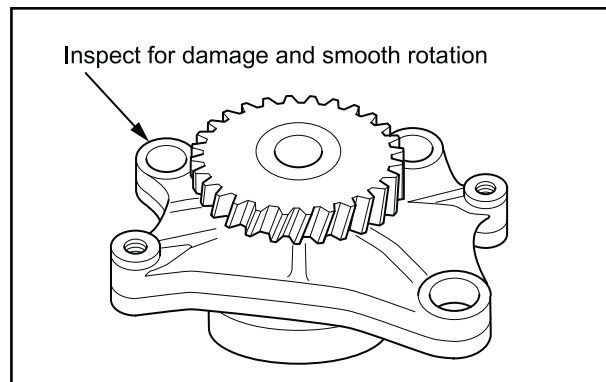

Inspecting oil pump

2.2 Inspecting relief valve

(1) Check the relief valve and its valve seat for contact condition. Check the spring for fatigue and damage. If it is faulty, replace the relief valve with new one.

(2) Measure the valve opening pressure (oil pressure when the engine is running at rated speed) of the relief valve. If the measured value is out of the standard, remove the plug and make an adjustment by increasing and decreasing the shim thickness.

Engine oil pressure take-out port

Next to the oil filter □ Rp 1/8 thread (PS 1/8)

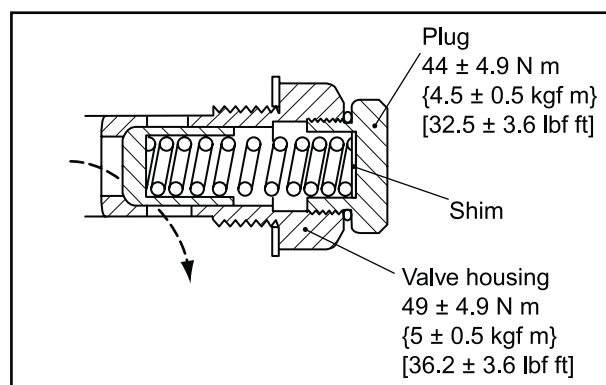

Inspecting relief valve

Item	Standard
Relief valve opening pressure	0.3 to 0.4 MPa {3 to 4 kgf/cm ² } [43 to 57 psi]

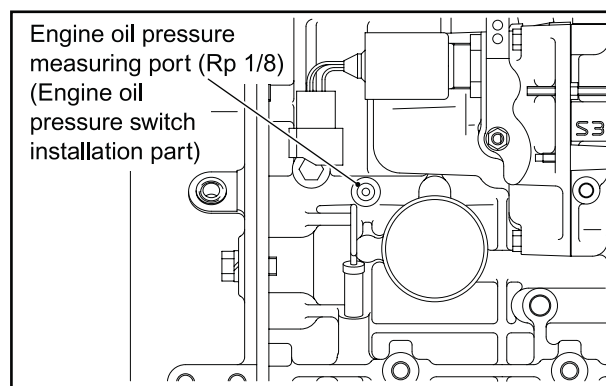

Engine oil pressure measuring port

LUBRICATION SYSTEM

2.3 Inspecting oil pressure switch

(1) Connect a tester (ohm range) between the terminal and body to check for continuity. The switch is normal if there is continuity between them. If there is no continuity, replace the switch.

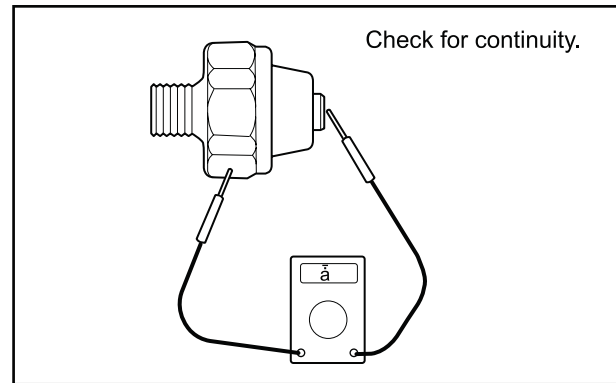

Inspecting oil pressure switch (1)

(2) Insert a thin rod from the oil hole and lightly push it. The switch is normal if there is no continuity between them. If there is continuity when the rod is pushed in, replace the switch.

(3) When air pressure of 0.05 MPa {0.5 kgf/cm²} [7.1 psi] is applied from the oil hole and there is no continuity, the switch is normal. Also check for air leaks. If there are air leaks, the diaphragm is damaged. Replace the switch.

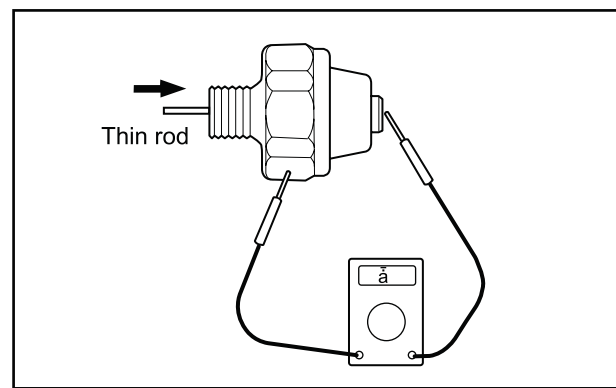

Inspecting oil pressure switch (2)

LUBRICATION SYSTEM

3. Installing lubrication system

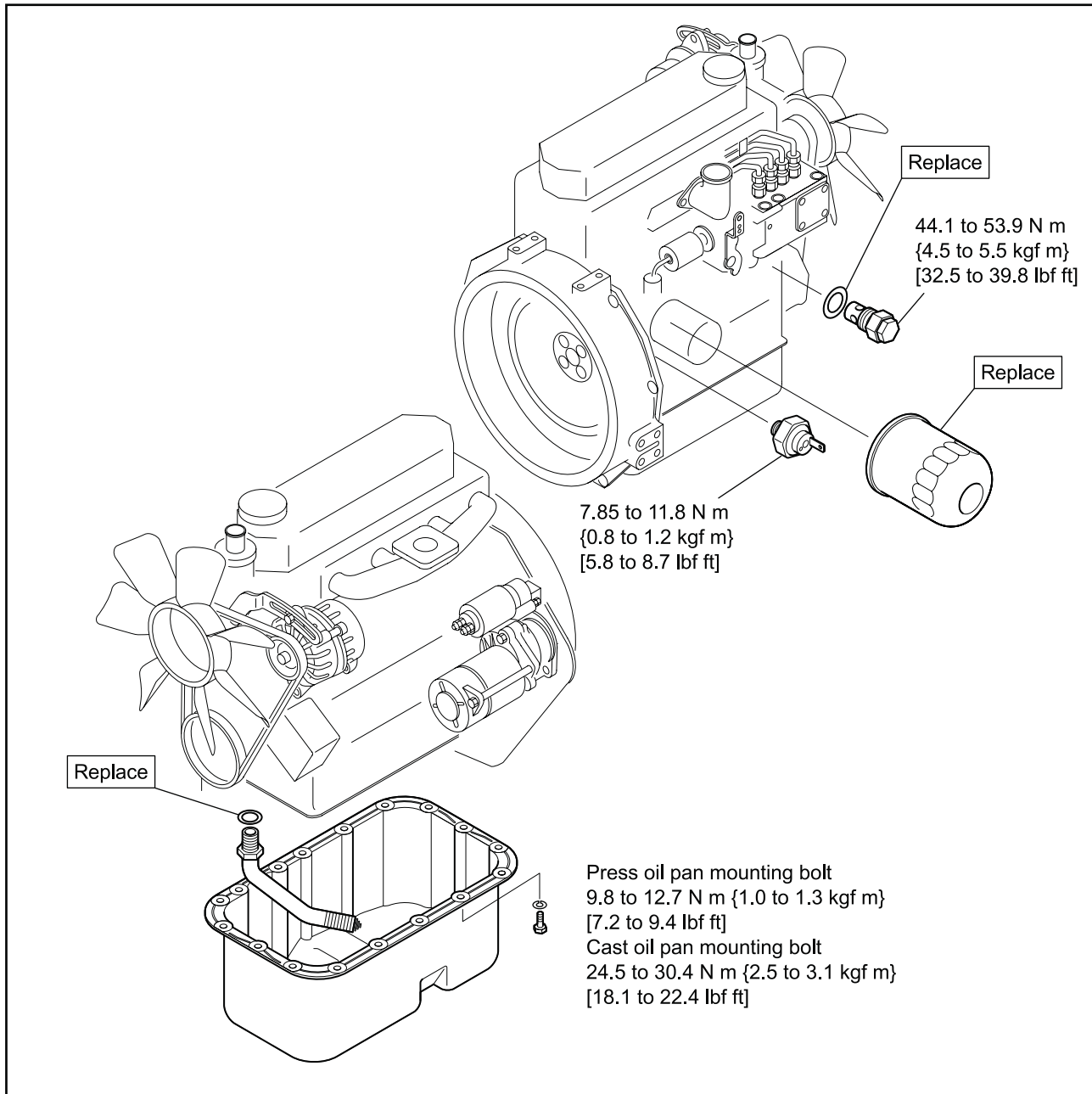

Installing lubrication system

LUBRICATION SYSTEM

3.1 Installing oil pressure switch

CAUTION

Do not allow sealant to squeeze out at the thread end.
Do not overtighten.

- (1) Using an oil pressure switch socket wrench, tighten the oil pressure switch to the specified torque.
- (2) Apply a sealant to the threaded portion when installing the switch.

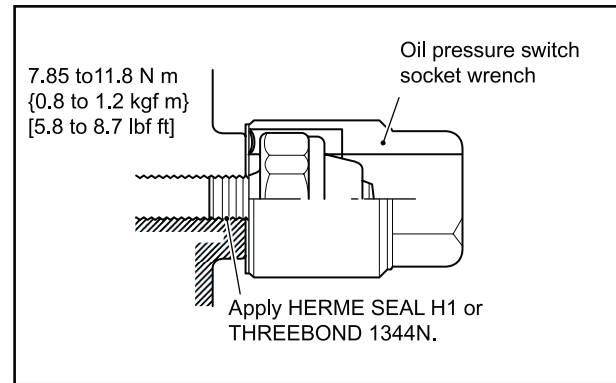

Installing oil pressure switch

3.2 Installing relief valve

Install the relief valve to the cylinder head side face, and tighten it to the specified torque.

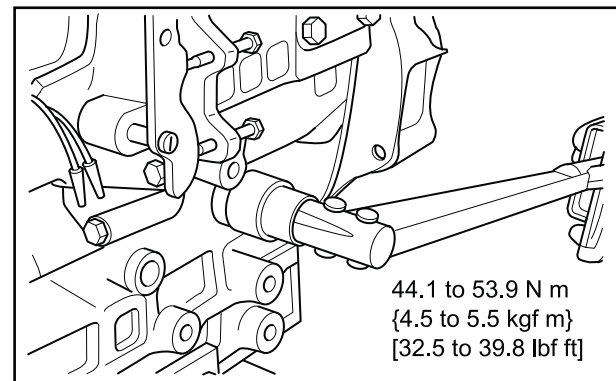

Installing relief valve

3.3 Installing oil filter

- (1) Apply a light coating of engine oil to the filter gasket.
- (2) Screw the filter in by hand. When the filter gasket contacts the mounting surface, screw the filter in another turn.

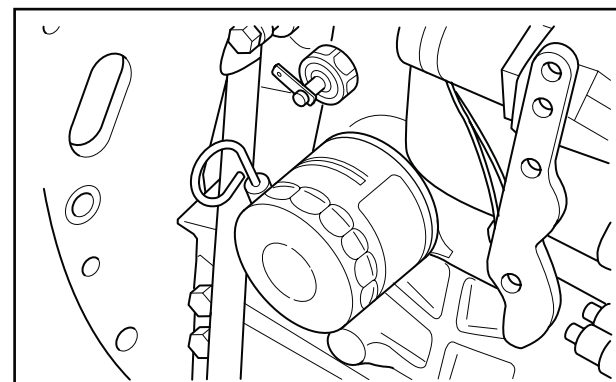

Installing oil filter

COOLING SYSTEM

1. Removing cooling system	D-100
2. Disassembling, inspecting and reassembling cooling system	D-101
2.1 Disassembling and inspecting thermostat	D-101
2.2 Inspecting thermostat	D-101
2.3 Inspecting thermostitch	D-102
2.4 Inspecting thermostat	D-102
2.4.1 Inspecting water pump for smooth rotation	D-102
3. Installing cooling system	D-103
3.1 Installing cooling system	D-103

COOLING SYSTEM

1. Removing cooling system

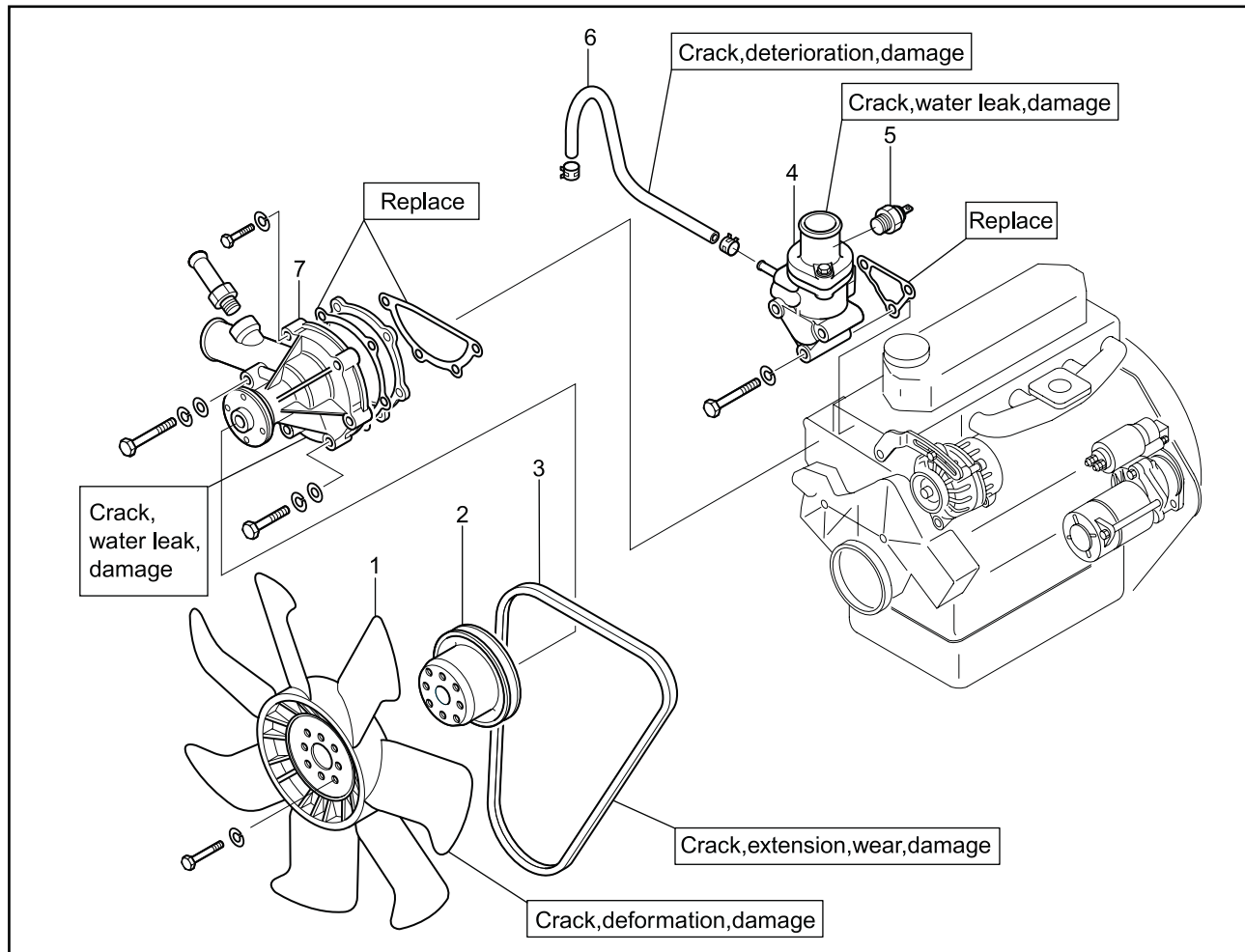

Removing cooling system

Disassembling sequence

- | | | |
|--------------|-------------------|--------------|
| 1 Fan | 4 Thermostat case | 7 Water pump |
| 2 Fan pulley | 5 Thermo switch | |
| 3 V-belt | 6 Pipe | |

COOLING SYSTEM

2. Disassembling, inspecting and reassembling cooling system

2.1 Disassembling and inspecting thermostat

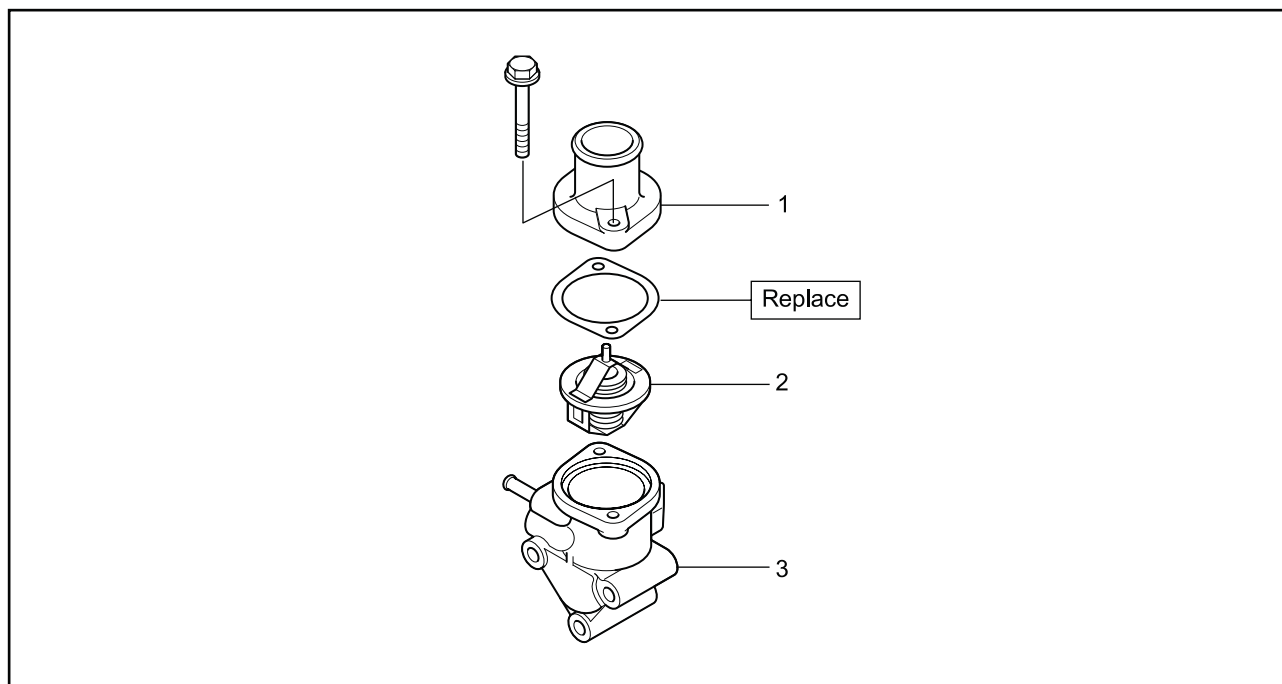

Disassembling and inspecting thermostat

Disassembling sequence

1 Thermostat cover

2 Thermostat

3 Thermostat case

2.2 Inspecting thermostat

CAUTION

Be careful of burns or a fire when measuring temperature, as it involves a high-temperature and open flame.

To test the thermostat operation, immerse the thermostat in a container filled with water. Heat the water, while measuring the water temperature. Record the temperature at the conditions shown in the table below. If the temperatures are not within the standard range, replace the thermostat.

Note: (a) Stir the water in the container with a stick to ensure uniform temperature distribution.

(b) Before installing the thermostat, be sure to check the valve opening temperature stamped on the thermostat valve side face.

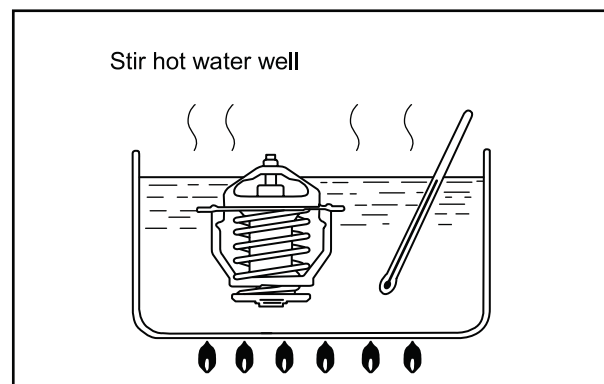

Inspecting thermostat

Temperature	Standard
Temperature at which valve starts opening	82 ± 1.5°C [179.6 ± 2.7°F]
Temperature at which valve lift is 8 mm [0.32 in.]	95°C [203°F]

COOLING SYSTEM

2.3 Inspecting thermostat

CAUTION

Both water and the thermostat become hot. Pay attention to prevent burn and fire.

Immerse the temperature-sensor in oil and measure the resistance while raising the oil temperature. If the resistance extremely deviates from the standard, replace the thermostat.

Temperature	Standard
105°C [221°F]	30 mΩ

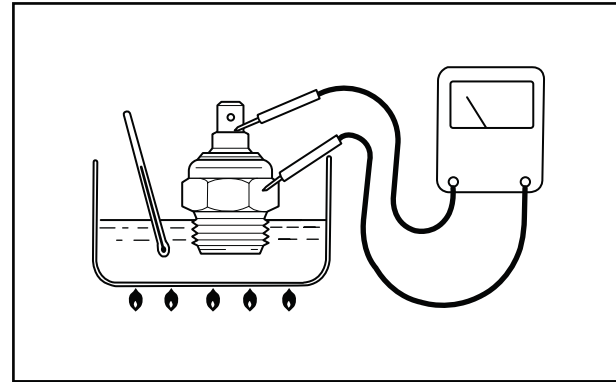

Reassembling thermostat

2.4 Inspecting thermostat

2.4.1 Inspecting water pump for smooth rotation

Check to make sure that the impeller and shaft of water pump rotate smoothly without noise and irregularities. If faulty, replace the water pump assembly.

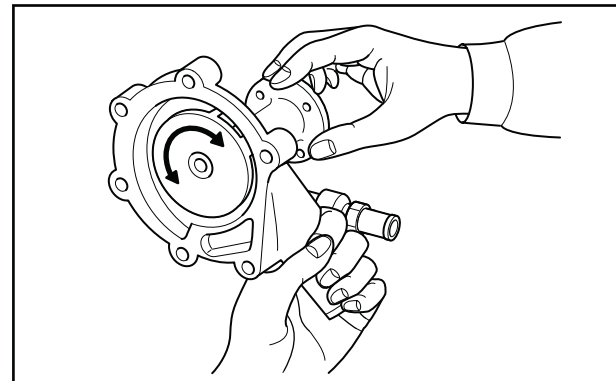

Checking impeller and shaft for smooth rotation

COOLING SYSTEM

3. Installing cooling system

3.1 Installing cooling system

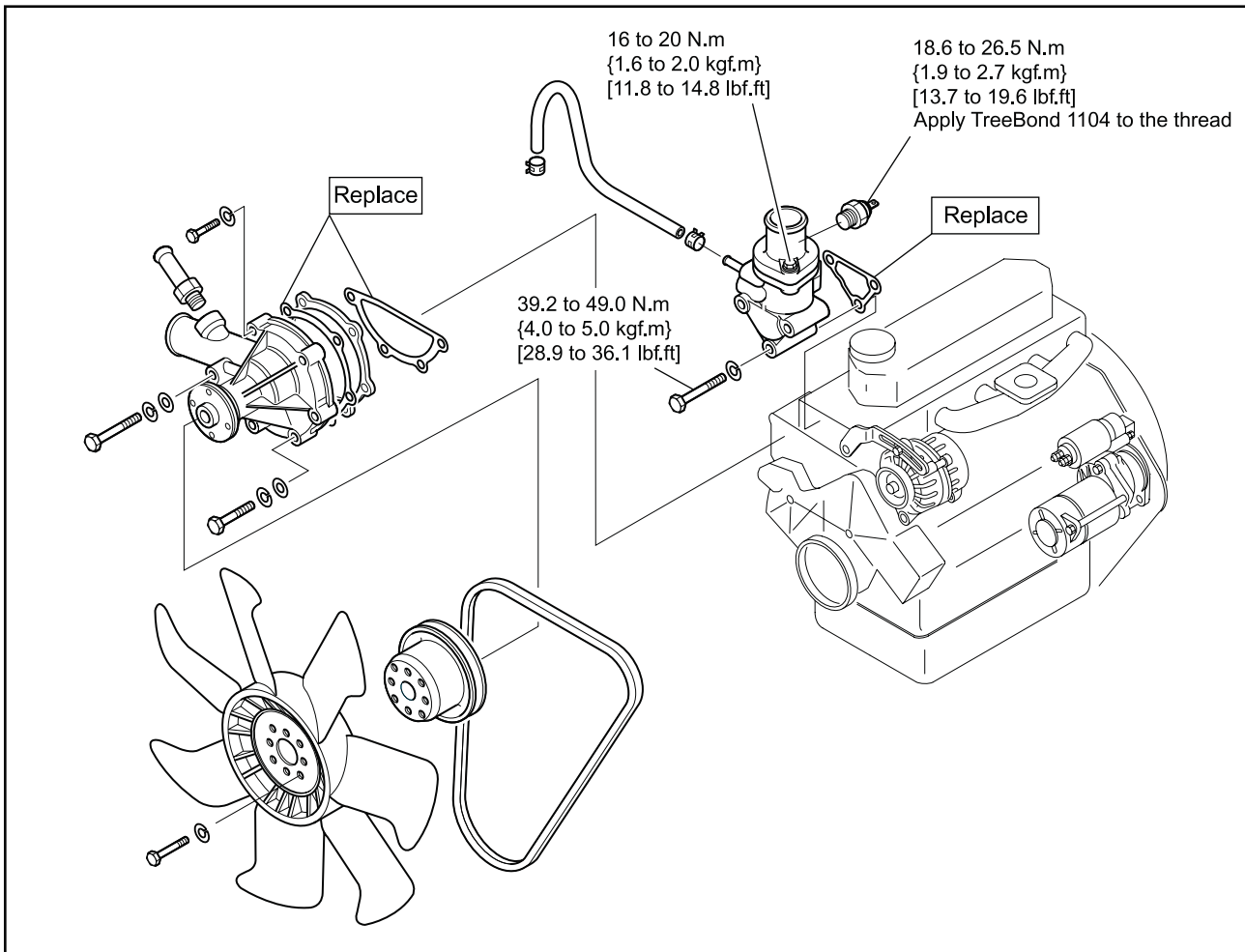

Installing cooling system

INLET AND EXHAUST SYSTEMS

1. Removing inlet and exhaust systems	D-105
1.1 Removing intake cover and exhaust manifold	D-105
2. Disassembling, inspecting and reassembling inlet and exhaust systems.	D-106
2.1 Inspecting intake cover and exhaust manifold	D-106
2.2 Measuring distortion of inlet and exhaust manifold.	D-106
3. Installing inlet and exhaust systems	D-107
3.1 Installing intake cover and exhaust manifold	D-107

INLET AND EXHAUST SYSTEMS

1. Removing inlet and exhaust systems

1.1 Removing intake cover and exhaust manifold

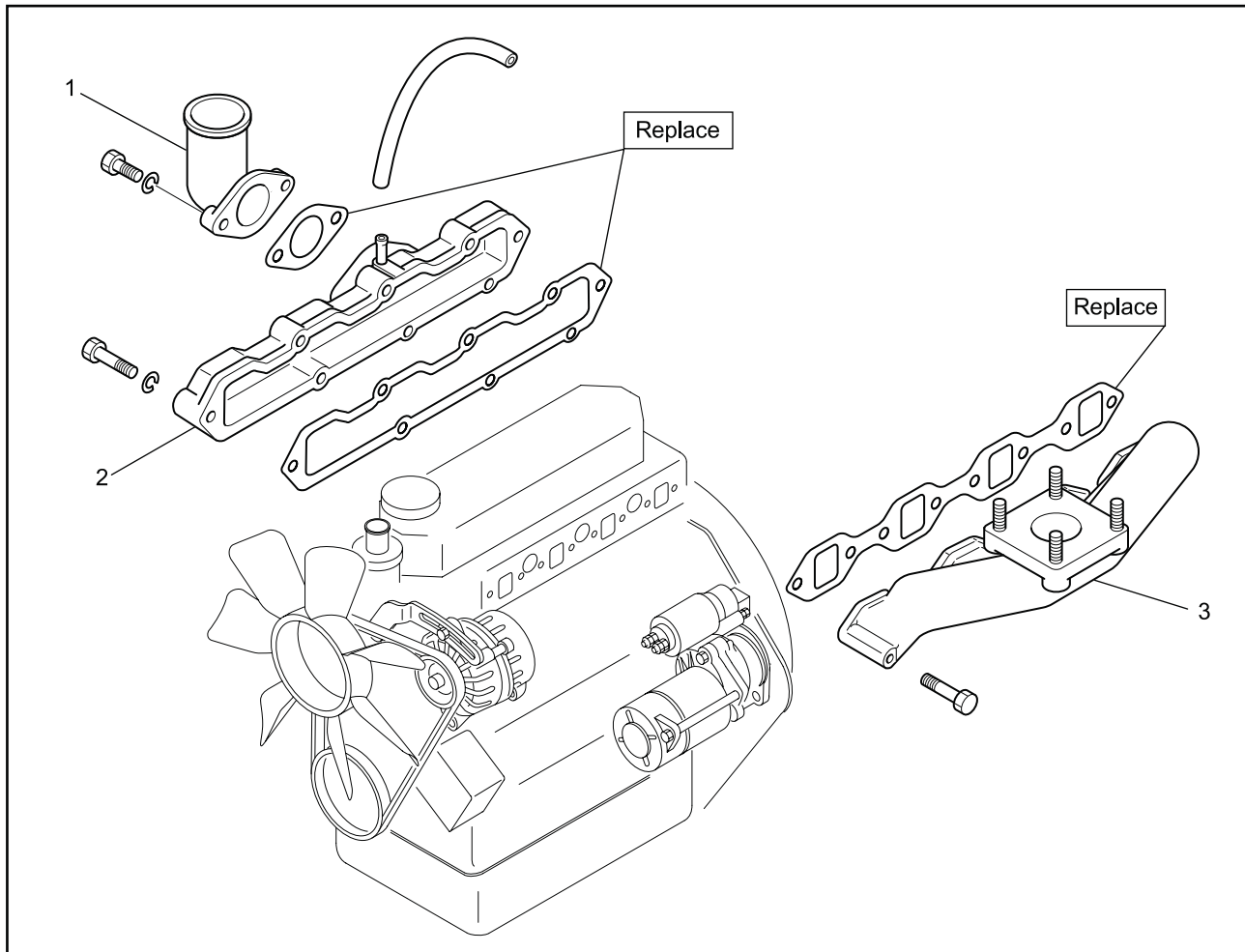

Removing intake cover and exhaust manifold

Removing sequence

1 Intake pipe

2 Intake cover

3 Exhaust manifold

INLET AND EXHAUST SYSTEMS

2. Disassembling, inspecting and reassembling inlet and exhaust systems

2.1 Inspecting intake cover and exhaust manifold

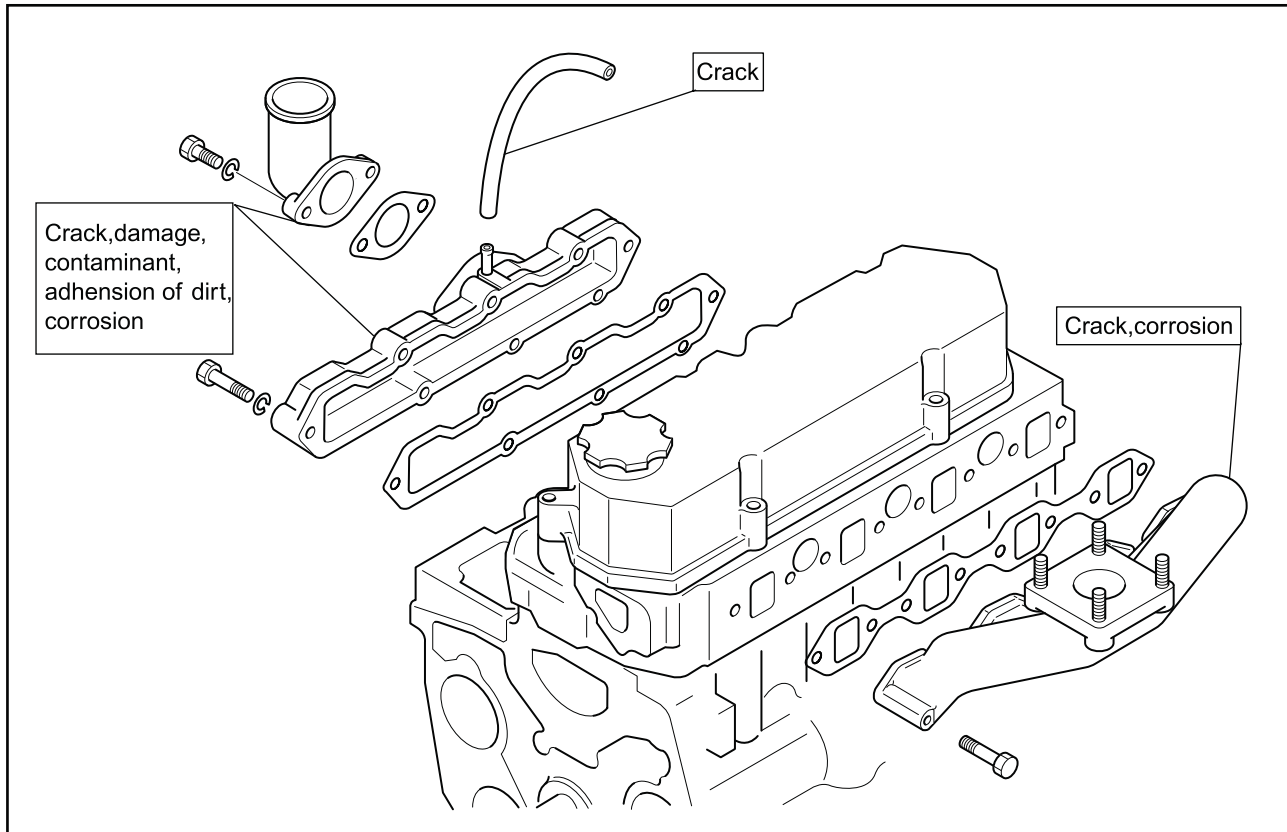

Inspecting intake cover and exhaust manifold

2.2 Measuring distortion of inlet and exhaust manifold

Using a straight edge and thickness gauges, measure distortion across the cylinder head mounting surfaces of the inlet cover and exhaust manifold. If the measured distortion exceeds the limit, correct by grinding or replace the part.

Item	Limit
Distortion on mounting surfaces of intake cover and exhaust manifold	0.15 mm [0.0059 in.]

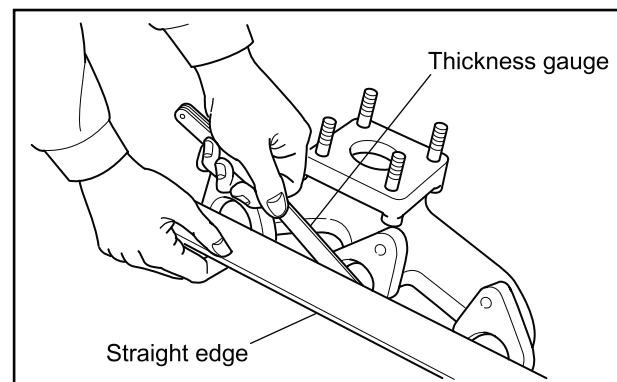

Measuring distortion on exhaust manifold

INLET AND EXHAUST SYSTEMS

3. Installing inlet and exhaust systems

3.1 Installing intake cover and exhaust manifold

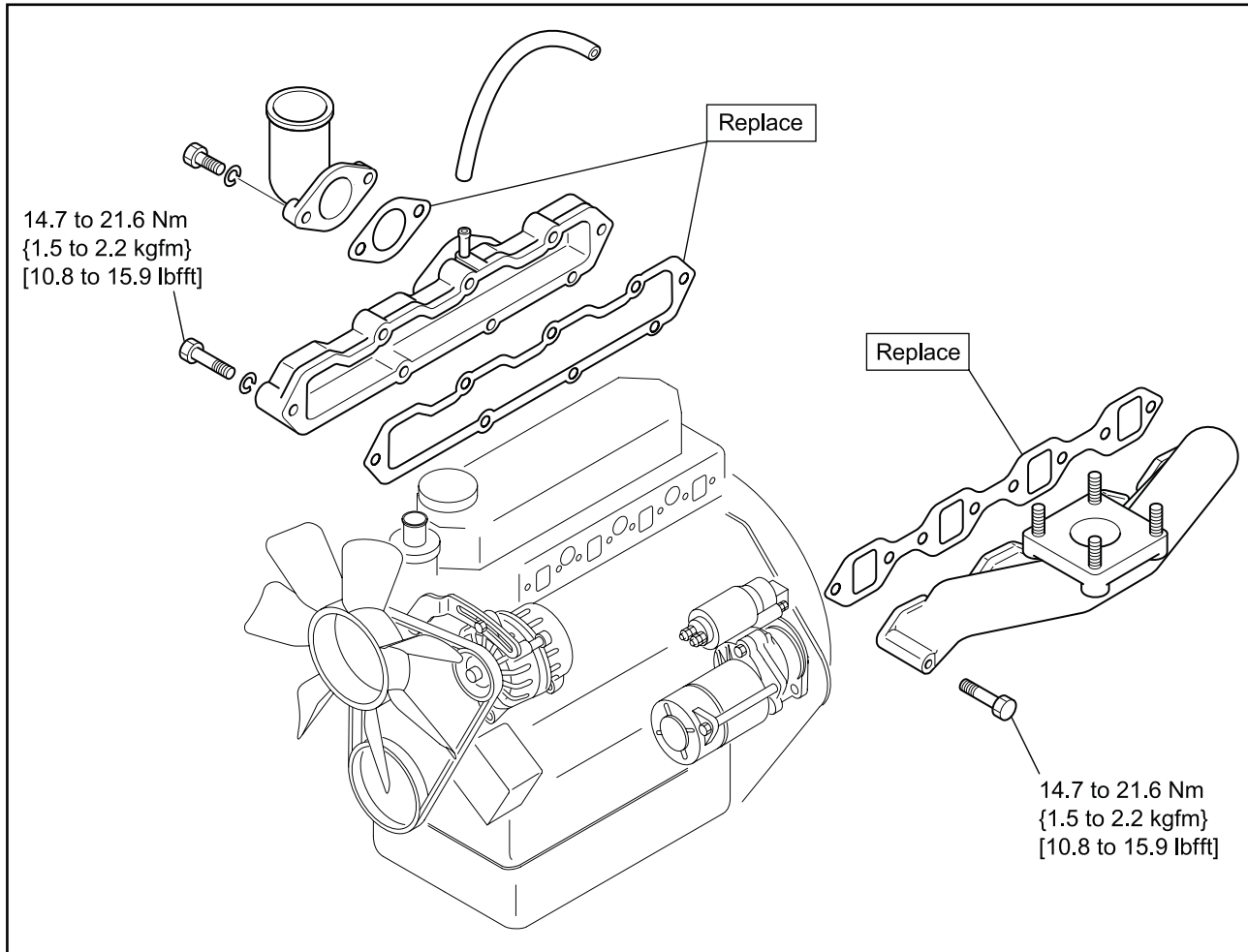

Installing intake cover and exhaust manifold

ELECTRICAL SYSTEM

1. Removing electrical system	D-110
1.1 Removing starter.	D-110
1.2 Inspection before removing alternator	D-111
1.2.1 Inspecting alternator operation	D-111
1.2.2 Handling precaution.	D-111
1.2.3 Inspecting regulated voltage (IC regulator integral type).	D-112
1.2.4 Inspecting output (a built-in IC regulator type).	D-112
1.3 Removing alternator	D-113
1.4 Removing stop solenoid	D-114
1.5 Removing glow plug	D-115
2. Disassembling, inspecting and reassembling electrical system	D-116
2.1 Gear reduction starter motor.	D-116
2.1.2 Handling precautions	D-117
2.2 Testing and troubleshooting	D-117
2.3 Assy view of starter motor.	D-118
2.4 Motor dismantling procedure	D-119
2.5 Troubleshooting of starter motor	D-122
2.6 Disassembling, inspecting and reassembling alternator.	D-123
2.6.1 Separating front bracket from stator	D-124
2.6.2 Removing pulley	D-124
2.6.3 Removing stator.	D-124
2.6.4 Inspecting rectifier	D-125
2.6.5 Inspecting rotor	D-125
2.6.6 Inspecting stator.	D-126
2.6.7 Inspecting brushes for wear.	D-126
2.6.8 Replacing brushes	D-127
2.6.9 Reassembling alternator	D-127
2.7 Inspecting glow plug	D-128
3. Installing electrical system	D-129
3.1 Installing glow plug	D-129

ELECTRICAL SYSTEM

3.2 Installing stop solenoid	D-130
3.3 Installing stop solenoid (ETR type)	D-131
3.3.1 Procedure for installing stop solenoid (ETR type)	D-131
3.3.2 Verification after reassembling (ETR type)	D-131
3.4 Installing stop solenoid (ETS type)	D-132
3.4.1 Procedure for installing stop solenoid (ETS type)	D-132
3.4.2 Verification after reassembly (ETS type)	D-133
3.5 Installing alternator	D-134
3.6 Installing starter	D-135

ELECTRICAL SYSTEM

1. Removing electrical system

1.1 Removing starter

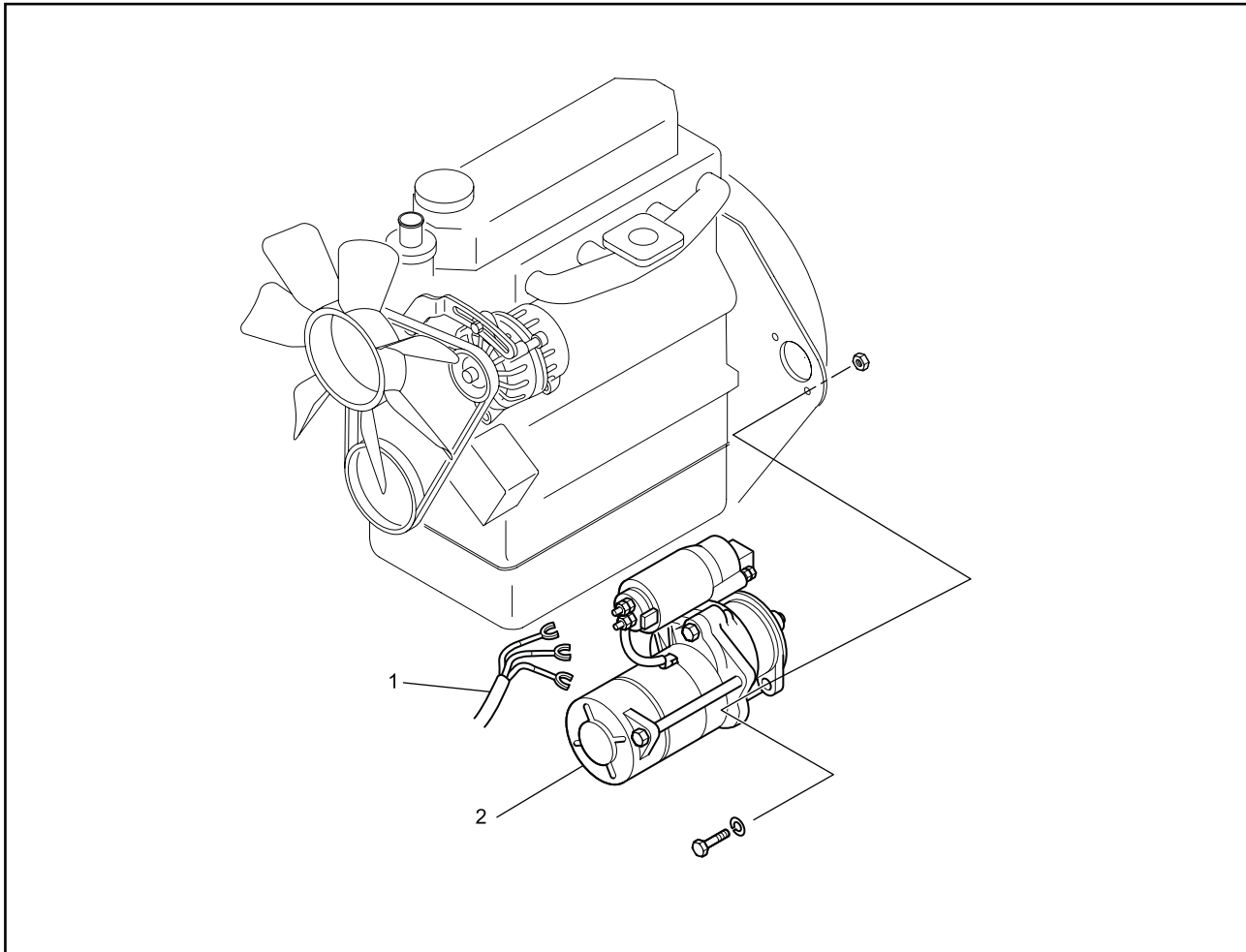

Removing starter

Removing sequence

1 Harness

2 Starter

ELECTRICAL SYSTEM

1.2 Inspection before removing alternator

1.2.1 Inspecting alternator operation

Locate the cause of faulty charging from malfunctions described below. Do not remove the alternator for inspection and repair unless inspection cannot be performed with the alternator installed on the engine.

Overcharge	Adjusted value of voltage regulator is high.
	Faulty battery.
Over discharge	Low adjusted value of voltage relay.
	Faulty alternator output.
	Electric power consumption is extremely high.
	Special load is used.
	Faulty wiring.

1.2.2 Handling precaution

Improper handling could cause damage or failure to the alternator.

- (1) Connect battery cables correctly. B terminal is positive (+), and E terminal is negative (-).
- (2) Do not use any high voltage tester such as megger.
- (3) Do not disconnect lead wire from B terminal of the alternator while the engine is running.
- (4) Battery voltage is constantly applied to B terminal of the alternator. Do not ground at this terminal.
- (5) Do not short circuit or ground at L terminal. (For a built-in IC regulator type)
- (6) When a steam cleaner is used, do not allow the steam directly contact the alternator.

ELECTRICAL SYSTEM

1.2.3 Inspecting regulated voltage (IC regulator integral type)

- (1) Disconnect (+) battery terminal and connect an ammeter across the line.
- (2) Connect a voltmeter between terminal L and ground.
- (3) The indication of the voltmeter must be 0 when the starter switch is OFF.
The indication of the voltmeter must be considerably lower than the battery voltage when the starter switch is ON (engine OFF).
- (4) Start the engine with the ammeter terminals disconnected.
- (5) Read the voltmeter (regulated voltage) while the ammeter reading is 5 A or lower, 2500 min⁻¹, and lamp switches OFF.

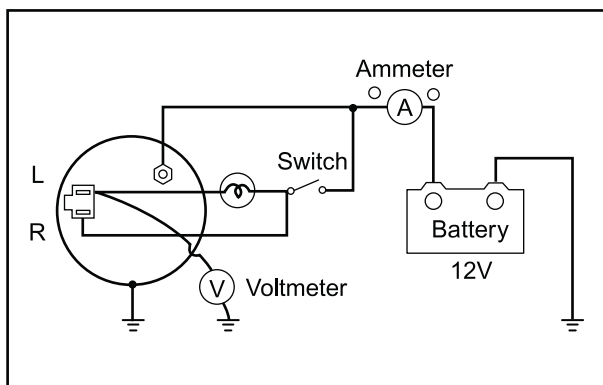

Checking regulated voltage

Item	Spec	Standard	Condition
Regulated voltage (at 20°C [68°F])	12 V - 50 A	14.4 to 15.0 V	5000 min ⁻¹ , 5A or lower, 20°C [68°F]

1.2.4 Inspecting output (a built-in IC regulator type)

- (1) Disconnect the battery ground cable.
- (2) Connect B terminal of the alternator to the ammeter, then connect the voltmeter between B terminal and ground.
- (3) Connect the battery ground cable.
- (4) Start the engine.
- (5) Immediately apply all loads such as lamps.
- (6) Increase the engine speed and measure the maximum output current at the specified alternator rotation speed with the voltmeter indicated the specified value.
- (7) If the measured value meets the standard, the output is normal.

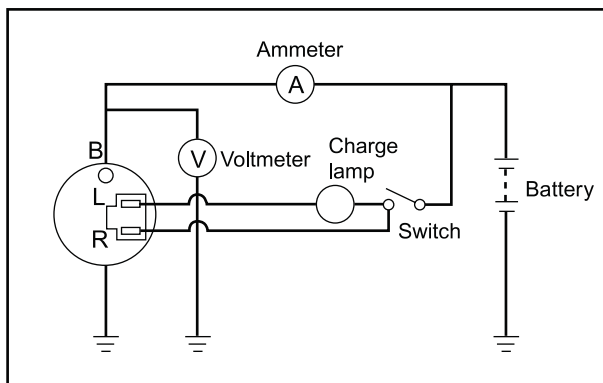

Inspecting regulated voltage

Item	Spec	Standard	
		Terminal voltage/current	Alternator rotation speed
Output characteristics (when hot)	12V - 50A	13.5V / 33A or higher	2500 min ⁻¹
		13.5V / 47A or higher	5000 min ⁻¹

ELECTRICAL SYSTEM

1.3 Removing alternator

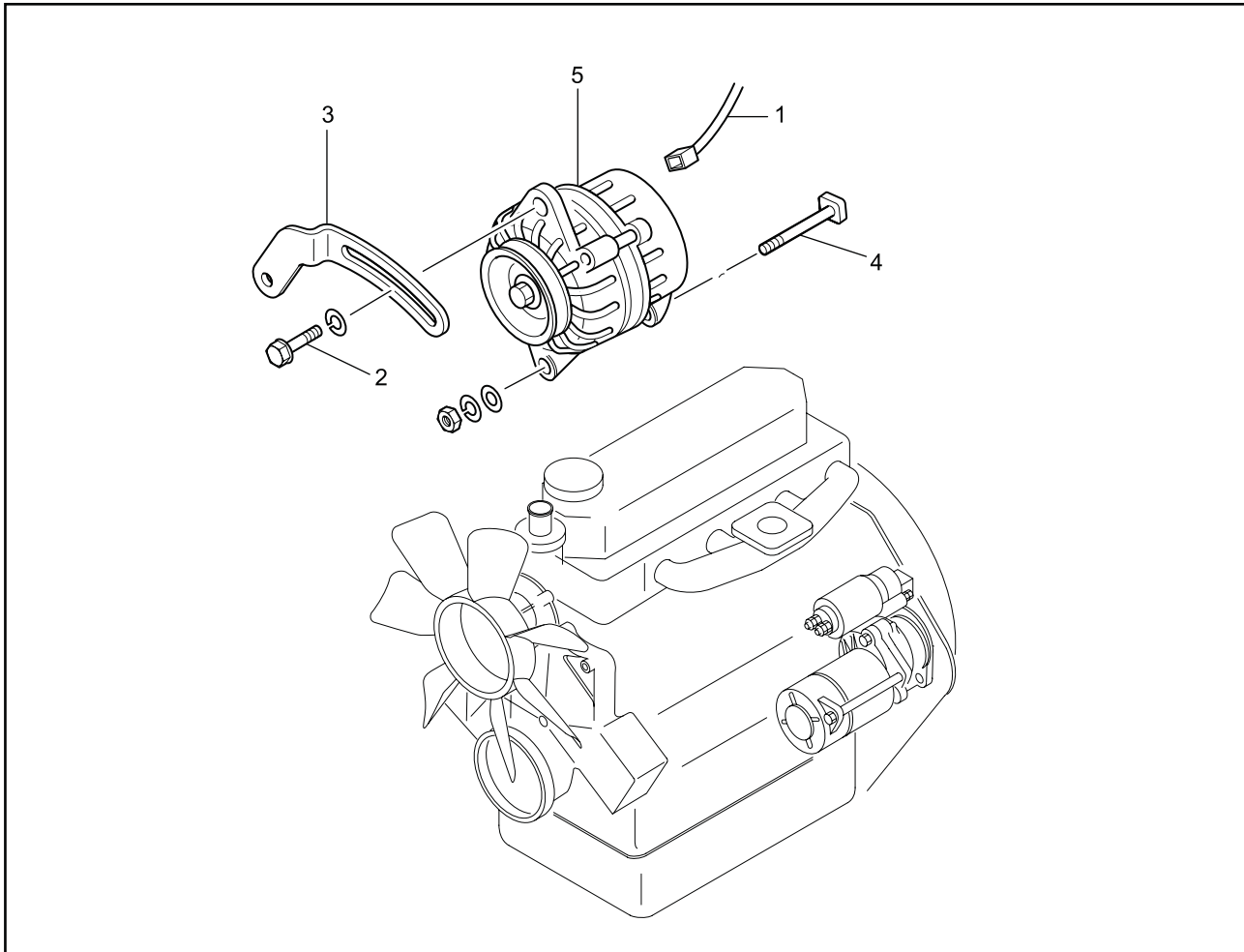

Removing alternator

Removing sequence

- 1 Harness
- 2 Flange bolt

- 3 Generator brace
- 4 Bolt

- 5 Alternator

ELECTRICAL SYSTEM

1.4 Removing stop solenoid

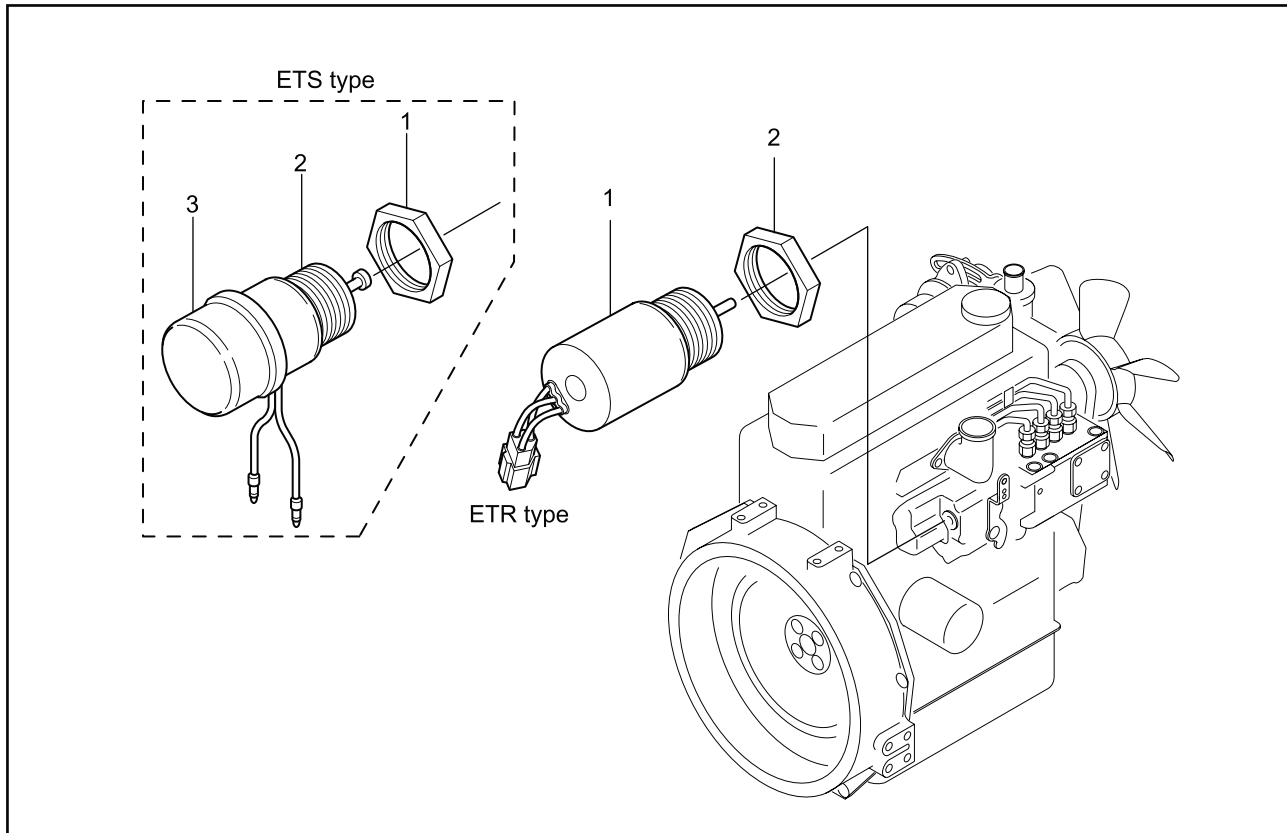

Removing stop solenoid

Removing sequence

1 Nut

2 Stop solenoid

3 Rubber cap (ETS type)

ELECTRICAL SYSTEM

1.5 Removing glow plug

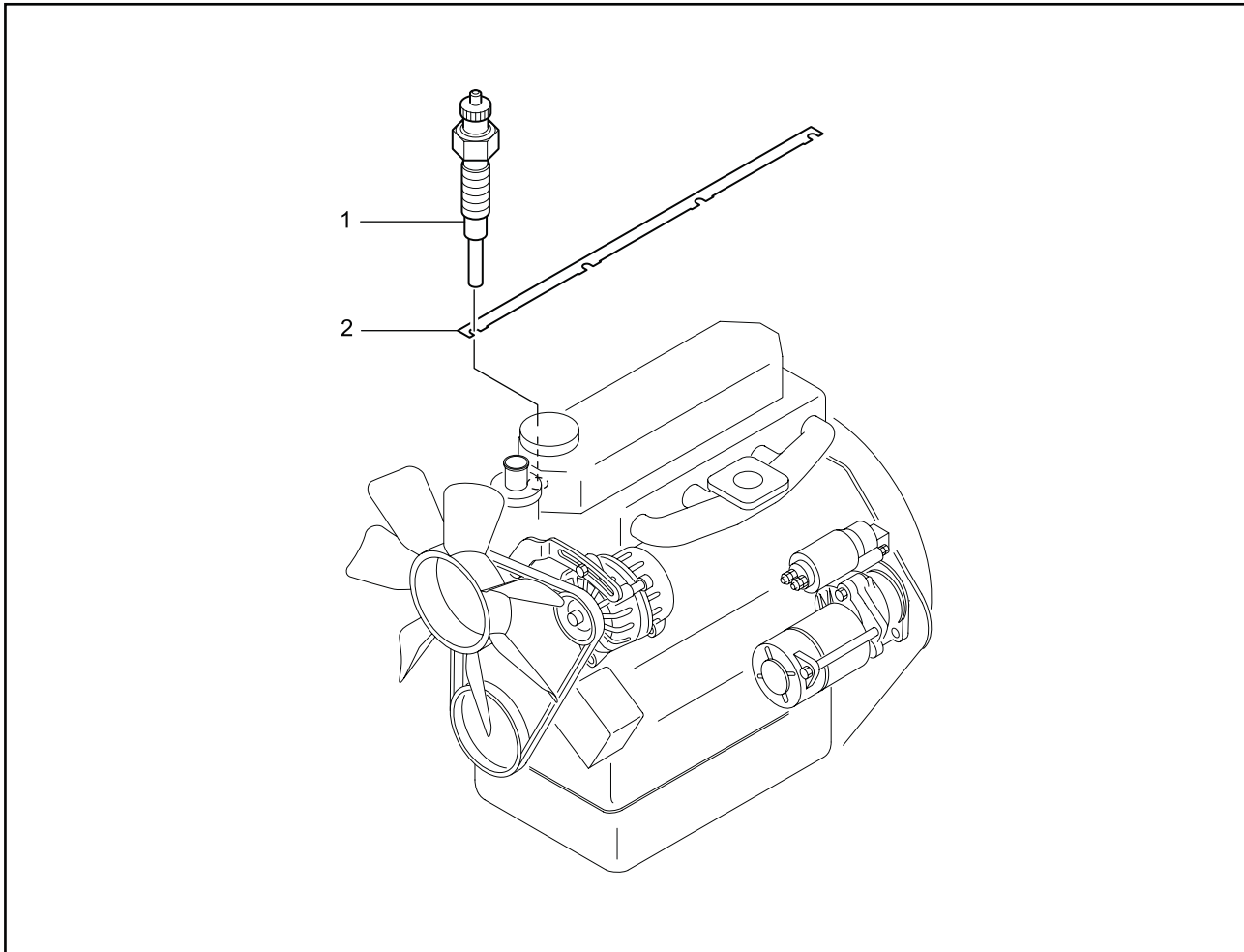

Removing glow plug

Removing sequence

1 Glow plug

2 Glow plug plate

2. Disassembling, inspecting and reassembling electrical system

GEAR REDUCTION STARTER MOTOR

Description & Functional aspects

This has a compact high speed motor with a reduction gear and a one way clutch operated pinion powered through a solenoid switch. While the motor is smaller and weighs lesser than the conventional 'direct on' starter motors, it runs at a higher speed. The reduction gear transfers power to the pinion gear delivering much greater torque and cranking strength as compared to the direct drive starter motor.

One way clutch prevents damage to the starter motor after the engine has started by disengaging its spring loaded pinion from the ring gear of the engine. If the starter pinion stays engaged long after the engine has started, the motor armature will be driven at very high speeds (as much as 40000 RPM) leading to the failure of the armature known as centrifuging. It is because the cranking speed of the engine is less than 300 RPM and once the engine has started, it will run at 10 to 15 times the cranking speed. Hence the one way clutch is a very important element for the life and safety of the starter

This is a pre-engaged starter motor. It means that the drive pinion is engaged with the ring gear prior to the motor starts spinning up so that the starter pinion & the ring gear of the engine have less wear due to meshing. This is achieved by a solenoid switch mounted above the starter. When the starter is switched ON, the solenoid pulls a plunger which is connected to an engaging lever that pushes the spring loaded pinion shaft into mesh with the ring gear. The plunger of the solenoid also pushes the moving contacts connecting the starter motor to the battery making it spin after the pinion gets into mesh with the ring gear. The solenoid thus helps to pre-engage the drive and switch the high starter current by a small control current through the starter button.

The gear reduction starter motors are replacing the conventional 'direct on' starter motors on all the applications worldwide due to their higher efficiency and output to size ratio which means a lower motor current and lesser cost.

ELECTRICAL SYSTEM

HANDLING PRECAUTIONS

- 1. Don't transport the motor without proper packing. If you are getting the motor from the manufacturer or dealer for replacement, make sure that there is no transit damage. If there is, please report the matter to the people concerned.**
- 2. Don't mount or remove the motor without disconnecting the battery leads.**
- 3. Use the appropriate tools and avoid hammering as it may break the aluminum brackets making the product unusable.**
- 4. Neither use excessive torque to tighten the nuts nor leave them loose. Use the specified torque and a torque wrench to fasten the nuts.**
- 5. Don't crank the engine continuously for more than a minute if it does not start. Allow the motor to cool for 15 minutes after 5 consecutive cranks.**

TESTING & TROUBLE SHOOTING:

If the motor does not crank, first check the battery for its voltage & clean the terminals. Check the connections (see fig.-1) and ensure that they are proper and the required voltage comes to the Motor terminals. In this condition if the motor does not crank, there is a fault in the starter motor.

The starting system combines both electrical & mechanical components. The cause of a starting problem may be electrical or mechanical. For each problem refer the table below for possible causes and remedial actions. Diagnosis starts with a thorough visual inspection to detect burnt conductors, damaged insulation, worn out brushes, bushes, sticky bearings, damaged commutator, heat set springs, etc. Testing includes starter motor current measurement, starter circuit voltage drop measurement, Meggar test for insulation, operational and continuity checks of control components and starter motor bench performance checks.

If the armature is found visually OK, then a drop test / growler test and meggar test will establish its functional suitability. If the commutator is worn out on the surface, a fine cut in the lathe should extend the life of the component. For the stator, if there is no dislocation of poles, no visible damage of insulation, welding of connection, meggar test will qualify the part for proper performance.

While replacing carbon brushes the correct grade and size is to be used. A different grade will cause excessive wear and failure of the product.

ELECTRICAL SYSTEM

BLOWNUP ASSEMBLY VIEW OF STARTER MOTOR:

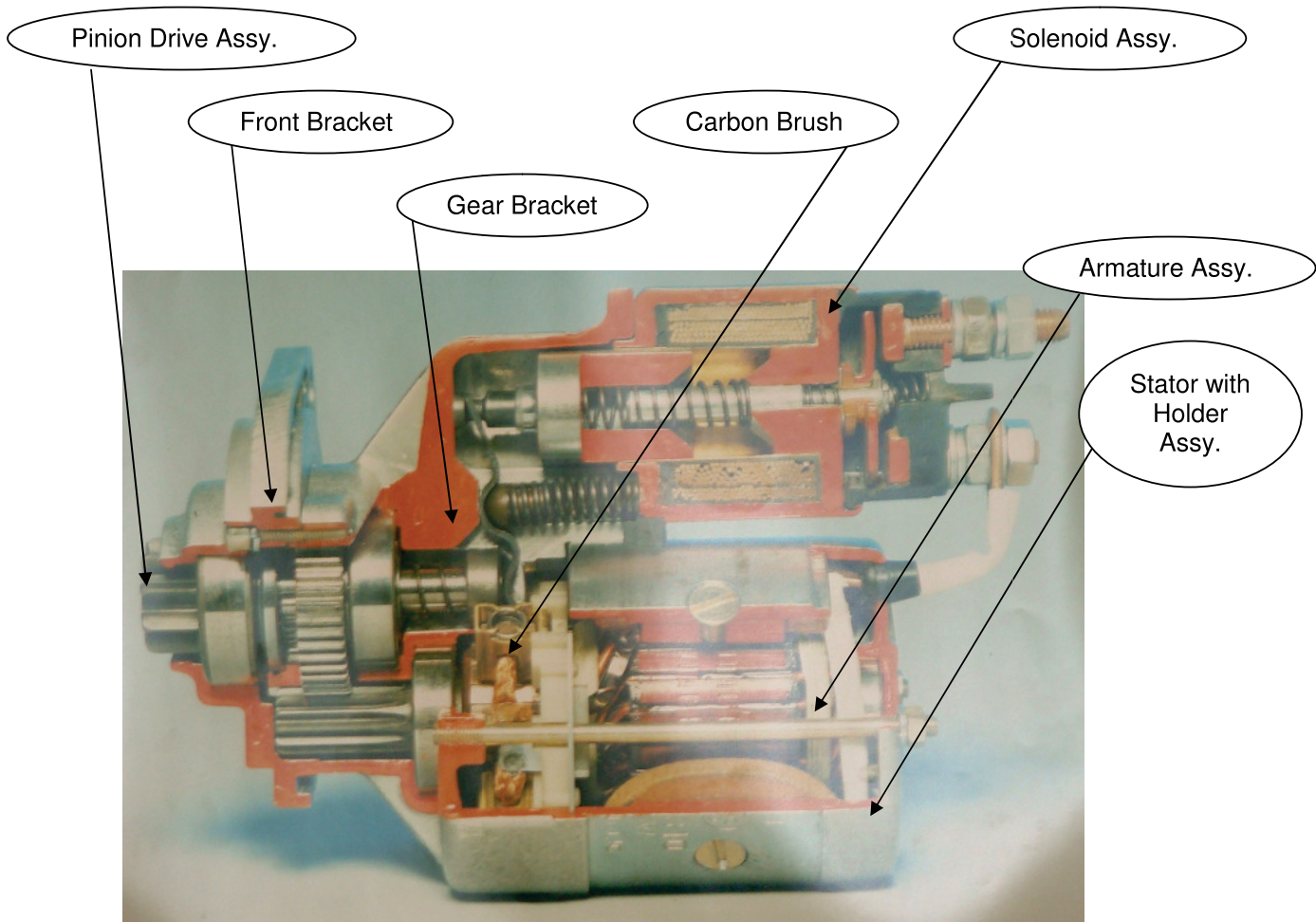

STARTER MOTOR TEST DIAGRAM:

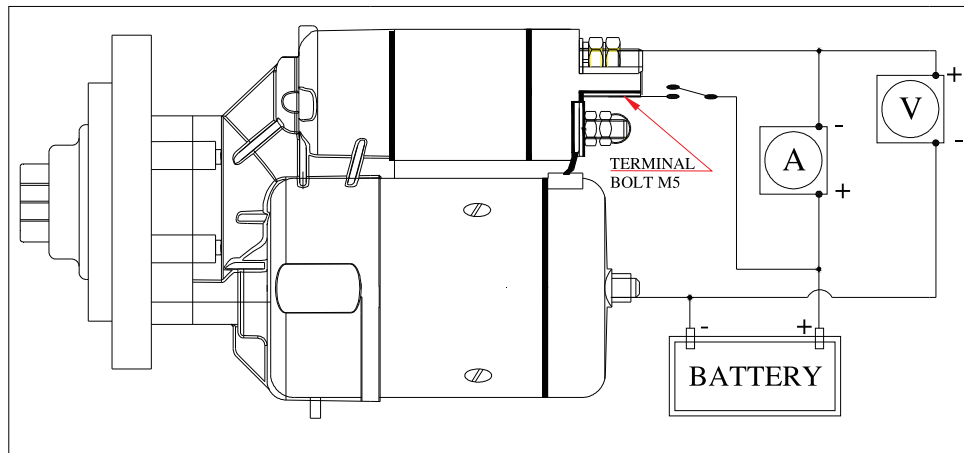

Fig.-1

ELECTRICAL SYSTEM

MOTOR DISMANTLING PROCEDURE – AFTER REMOVING FROM THE ENGINE

FOR DEFECTIVE DRIVE & SOLENOID SWITCH

- I) Unscrew the allen screw (4 nos.) of the front bracket and remove the pinion drive assembly to check the assembly
- II) Remove the copper connector (flexible wire) & solenoid from starter body.
- III) Open the solenoid switch by unscrewing 3 nos.screws to check.
- IV) Remove shift lever, spring & ball pin to check their condition.

FOR DEFECTIVE BODY ASSEMBLY/ARMATURE ASSEMBLY

- I) Remove the copper connector (flexible wire) connecting solenoid switch.
- II) Unscrew the set screw nut and remove the rear end bracket.
- III) Remove the body assembly and armature assembly from the rest of the assembly to check.
- IV) Remove armature from the body assembly carefully to avoid damage to carbon brushes.
- V) Remove carbon brushes from the brush holder to check the condition of spring & brush.
- VI) Replace brushes/ brush holder if the wear is more than 75%.

ELECTRICAL SYSTEM

ARMATURE ASSEMBLY-

Fouling marks on the armature core indicate worn out the ball bearing of armature or needle roller bearing of the gear bracket. Check the armature as given procedure

1-A) Check the armature for inter turn winding short circuit and conductor continuity on a growler tester as shown in given photo. The magnetic noise will indicate the failed armature.



OK (No magnetic noise)

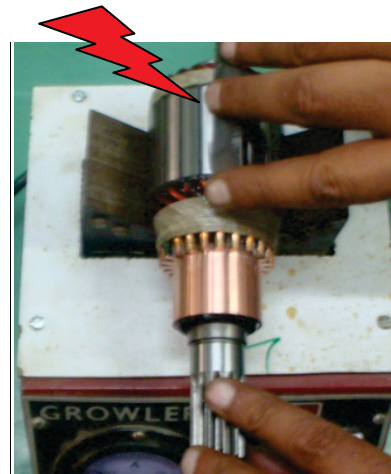

NOT OK (Magnetic noise)

B) The body short can be checked, using a 440 AC series test lamp as shown in given photo. The bulb must not light when the probes are connected between any one commutator segment and armature core

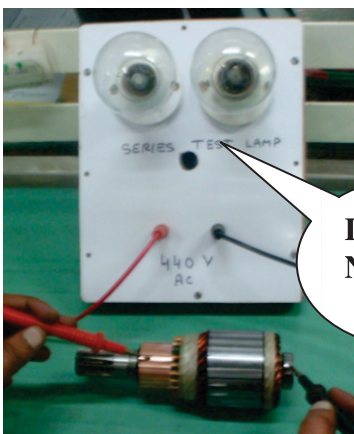

OK

LAMP
NOT ON

LAMP
ON

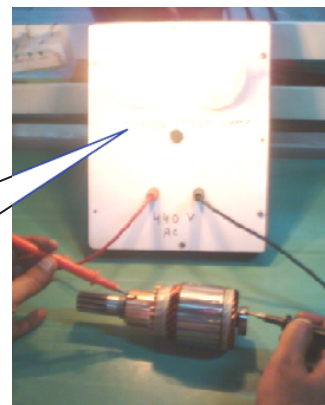

NOT OK

ELECTRICAL SYSTEM

SOLENOID SWITCH ASSEMBLY-

- 1) Solenoid switch can be checked by the free movement of the plunger assy. Replace with new solenoid in case the plunger is not in free movement.
- 2) Apply 12V DC supply between solenoid terminal and body of the solenoid. The Plunger should move in and contact between terminals can be checked by a continuity meter connected across the main terminals as shown below.

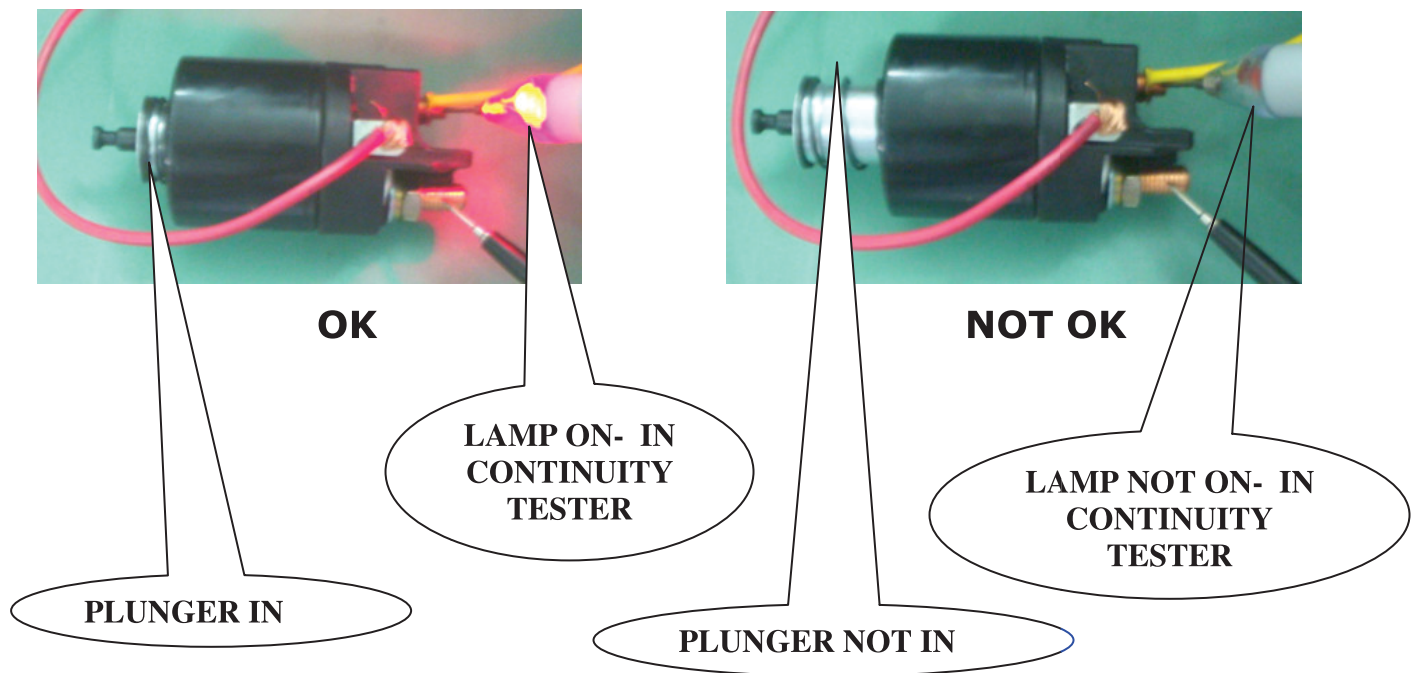

TROUBLE SHOOTING CHART

<u>PROBLEM</u>	<u>POSSIBLE CAUSES</u>	<u>ACTION NEEDED</u>
STARTER DOES NOT WORK.	1) DEAD BATTERY. 2) OXIDISED/DIRTY TERMINALS. LOOSE CONNECTIONS 3) FAULTY IGNITION SWITCH.	1) CHARGE / REPLACE BATTERY. 2) CLEAN THE TERMINALS. TIGHTEN CONNECTIONS & APPLY GREASE. 3) CHECK SWITCH – REPAIR / REPLACE IF REQUIRED.
STARTER CRANKS BUT THE ENGINE DOES NOT FIRE.	1).WEAK BATTERY. 2)BLOCKED FUEL LINES/AIR TRAPPED IN FUEL LINES 3) FAULTY STARTER.	1) CHECK BATTERY & RECHARGE. REPLACE WITH A NEW BATTERY. 2) CHECK THE FLOW OF FUEL. REMOVE BLOCKS AND AIRLOCKS. 3) CHECK THE BRUSHES, SPRING TENSION & ARMATURE.
STARTER WORKS BUT PINION DOES NOT ENGAGE.	1) PINION STICKY ON SHAFT. 2) DAMAGED SHIFT LEVER.	1) CHECK THE DRIVE MOVEMENT ON THE SHAFT- CHANGE THE PINION ASSY.IF NOT FOUND OK. 2) CHANGE THE SHIFT LEVER.
STARTER CONTINUES TO RUN AFTER SWITCH IS RELEASED.	1) DAMAGED PINION OR RING GEAR TEETH. 2) FAULTY IGNITION SWITCH. 3) FAULTY SOLENOID SWITCH 4) STICKY DRIVE ASSEMBLY	1) DEBURRING OF PINION /RING GEAR TEETH OR REPLACE. 2) REPAIR/REPLACE THE IGNITION SWITCH. 3) REPAIR/REPLACE THE SOL. SWITCH 4)CHECK DRIVE ASSEMBLY MOVEMENT ON SHAFT.
STARTER ENGAGES WITH RING GEAR BUT ENGINE DOES NOT CRANK.	1) SLIPPAGE OF CLUTCH (PINION DRIVE ASSEMBLY). 2)DEFECTIVE SOLENOID SWITCH. 3) WEAK/ DEAD BATTERY 4) JAMMED ENGINE	1) CHANGE THE DRIVE ASSEMBLY. 2) REPAIR/REPLACE THE SOLENOID SWITCH. 3) REPLACE WITH FULLY CHARGED BATTERY 4)REPAIR THE ENGINE

ELECTRICAL SYSTEM

2.6 Disassembling, inspecting and reassembling Alternator

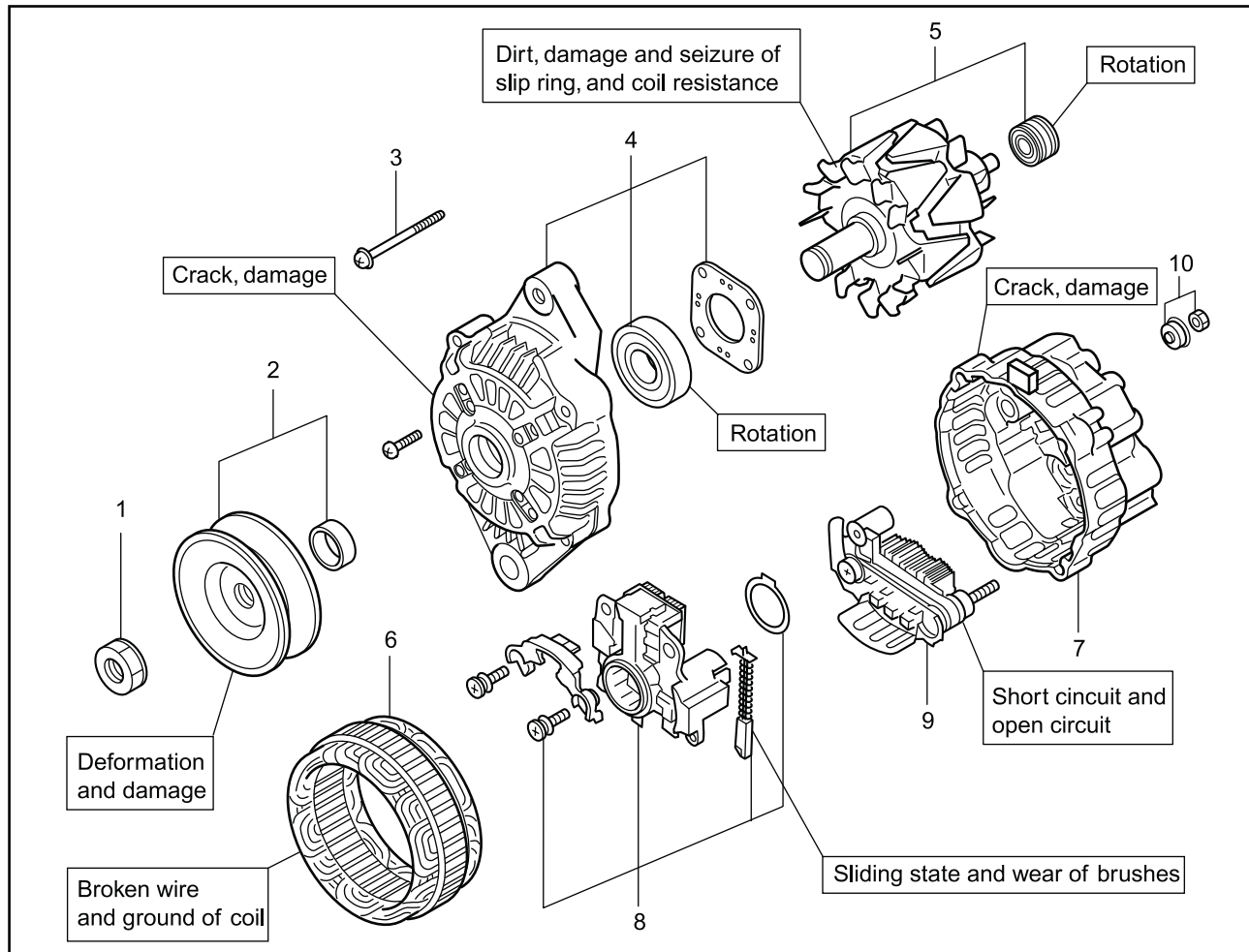

Disassembling, inspecting and reassembling alternator (12V - 40A)

Disassembling sequence

- | | | |
|--------------------------|------------------|-------------|
| 1 Nut | 5 Rotor, bearing | 9 Rectifier |
| 2 Pulley, spacer | 6 Stator | 10 Nut set |
| 3 Through bolt | 7 Rear bracket | |
| 4 Front bracket, bearing | 8 Regulator | |

ELECTRICAL SYSTEM

2.6.1 Separating front bracket from stator

CAUTION

Do not disassemble the alternator unless the repair is necessary.

Do not insert the screwdrivers too deep, as it can damage the stator.

- (1) Remove the through bolts.
- (2) With two flat-head screwdrivers inserted between the front bracket and stator, pry them apart.

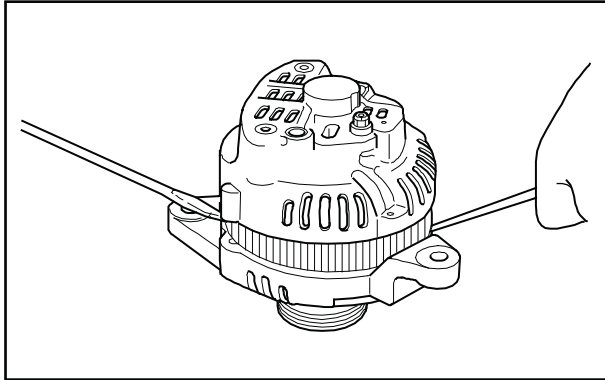

Separating front bracket from stator

2.6.2 Removing pulley

CAUTION

When setting the rotor in a vise, be sure to hold the base of the rotor claw. Do not hold the rotor claw, as it causes damage to the claw.

- (1) Apply a cloth to the rotor and set it in a vise.
- (2) Remove the pulley nut and then pull out the pulley and spacer.
- (3) Remove the rotor from the front bracket.

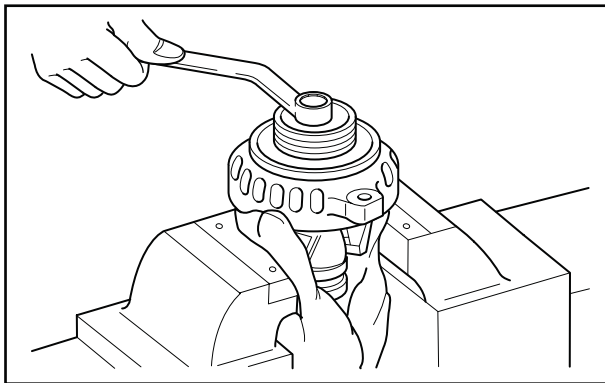

Removing pulley

2.6.3 Removing stator

CAUTION

Unsoldering must be finished as quickly as possible. Extended heating will damage the diodes.

- (1) Cut off the joint of the stator and remove the stator from the rectifier.
- (2) Unscrew the rectifier mounting screws, and dismount the rectifier.

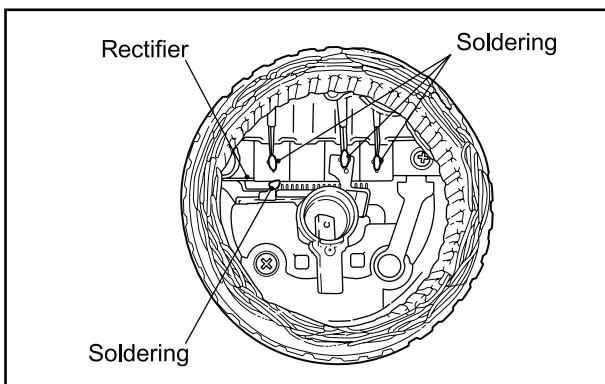

Removing stator

ELECTRICAL SYSTEM

2.6.4 Inspecting rectifier

Check that diodes in a rectifier function properly. To check, measure both negative (-) and positive (+) resistance alternately twice. If both infinite negative and infinite positive resistances are observed, the diode is open-circuited. If measured value is close to 0Ω , the diode is short-circuited. In either case, replace the rectifier with a new one.

Note: Use a wide measuring range as much as possible. The current flow during test is significantly lower than the current that normally flows in the rectifier, by which the accurate resistance may not be measured using a tester, and this tendency is noticeable if the measuring range is small.

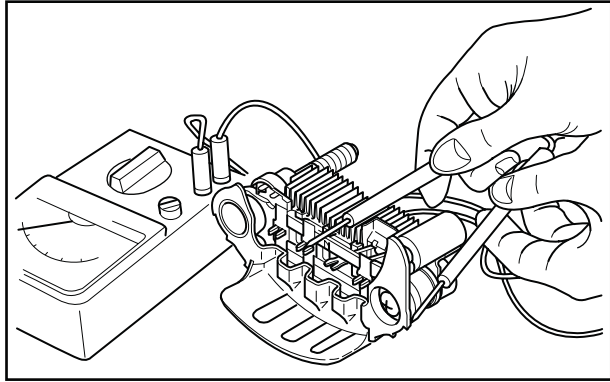

Inspecting rectifier

2.6.5 Inspecting rotor

(1) Check that there is continuity between slip rings. If no continuity is observed, replace the rotor with a new one.

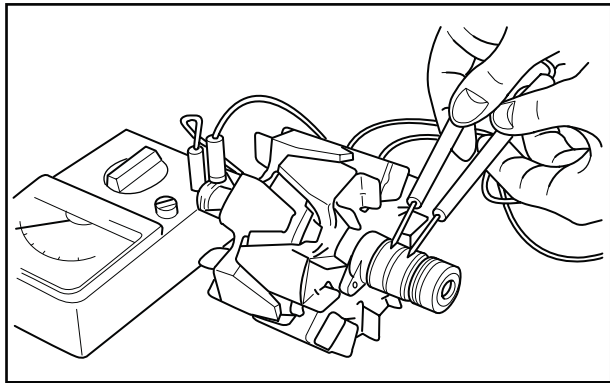

Inspecting field coils for continuity

(2) Check that there is no continuity between the slip ring and the shaft (or the core). If continuity is observed, replace the rotor with a new one.

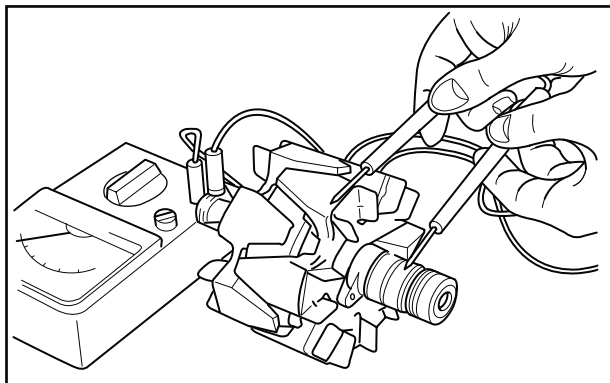

Checking field coils for grounding

ELECTRICAL SYSTEM

2.6.6 Inspecting stator

(1) Checking continuity between lead wires

Check that there is continuity between a pair of lead wires.

Also check that there is no continuity between a pair of lead wires and other pair of lead wires.

If defective, replace the stator.

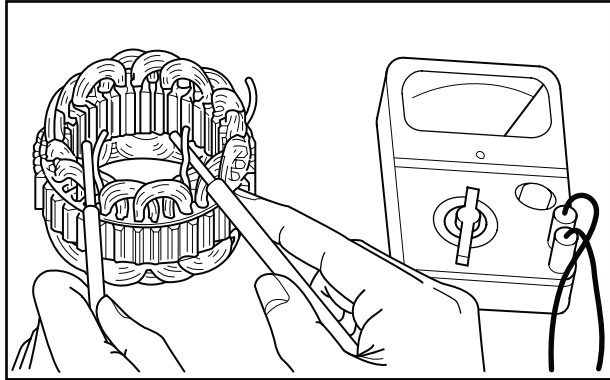

Checking for continuity between leads

(2) Checking insulation between lead wire and core

Check that there is no continuity between each lead wire and the stator core. If continuity is observed, replace the stator.

Note: The core cannot be replaced as a single item.

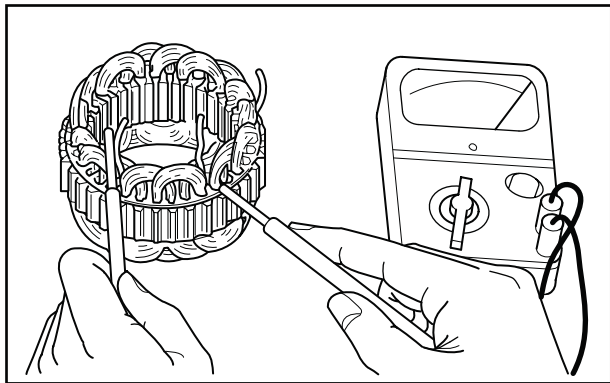

Checking for grounding between the leads and the core

2.6.7 Inspecting brushes for wear

Measure the length of the brushes. If the measured value is less than the limit, replace both the brush holder assembly and the brush assembly with new ones.

Item	Standard	Limit
Brush length	18.5 mm [0.7283 in.]	5.0 mm [0.197 in.]

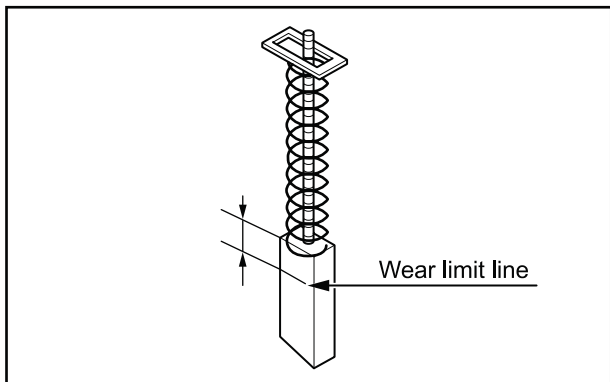

Inspecting brushes

ELECTRICAL SYSTEM

2.6.8 Replacing brushes

- (1) To remove the brush and the spring, unsolder the brush lead.

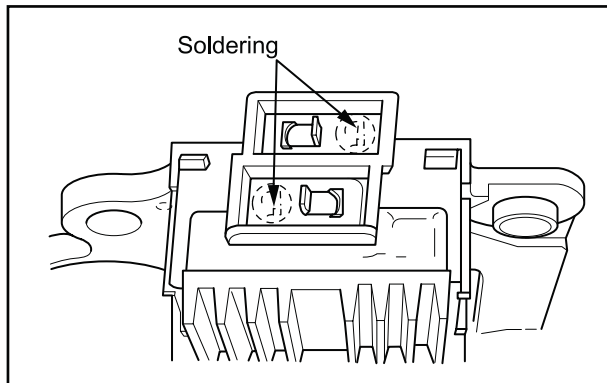

Replacing brushes

- (2) To install a new brush, push the brush into the brush holder as shown in the illustration, and then solder the lead to the brush.

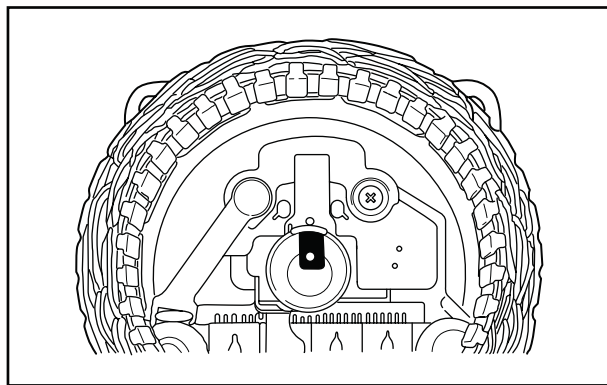

Installing brushes

2.6.9 Reassembling alternator

Assemble the alternator in reverse order of disassembly. Key assembly steps follow.

- (1) Locate the eccentric groove on the periphery of the rear bearing. Insert the rotation retaining snap ring so that the highest protruded section of the ring is positioned at the deepest section of the groove.
- (2) When replacing the rear bearing, press-fit the rear bearing so that the groove on the periphery of the bearing faces the snap ring side.
- (3) When press-fitting the rear bearing into the rear bracket, heat the rear bracket to 50 to 60°C [122 to 140°F] first.
- (4) Before installing the rotor to the rear bracket, lift the brushes by inserting a wire through a small hole in the rear bracket, then remove the wire after completing the reassembly.

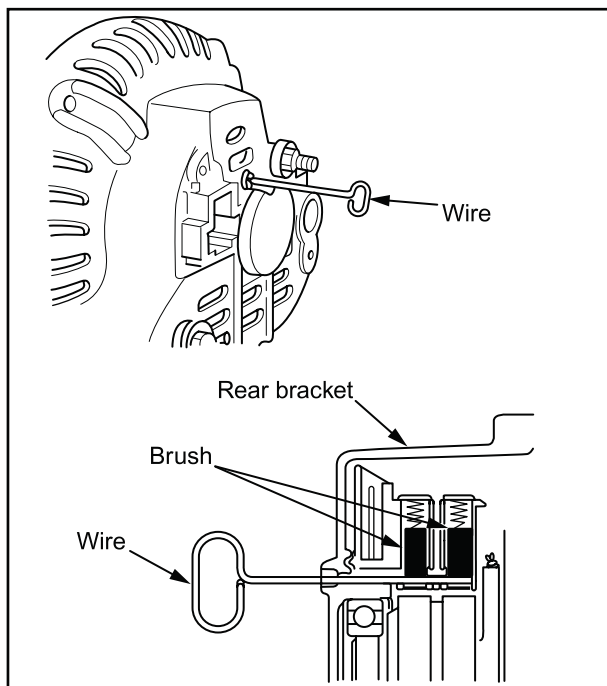

Reassembling alternator

ELECTRICAL SYSTEM

2.7 Inspecting glow plug

Check continuity between the terminal and the body as shown in the illustration. If no continuity is indicated, or the resistance is large, replace the glow plug with a new one.

Item	Standard
Resistance value	0.55 Ω

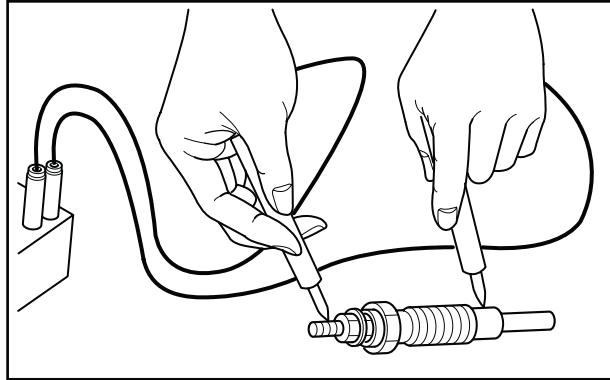

Inspecting glow plug

ELECTRICAL SYSTEM

3. Installing electrical system

3.1 Installing glow plug

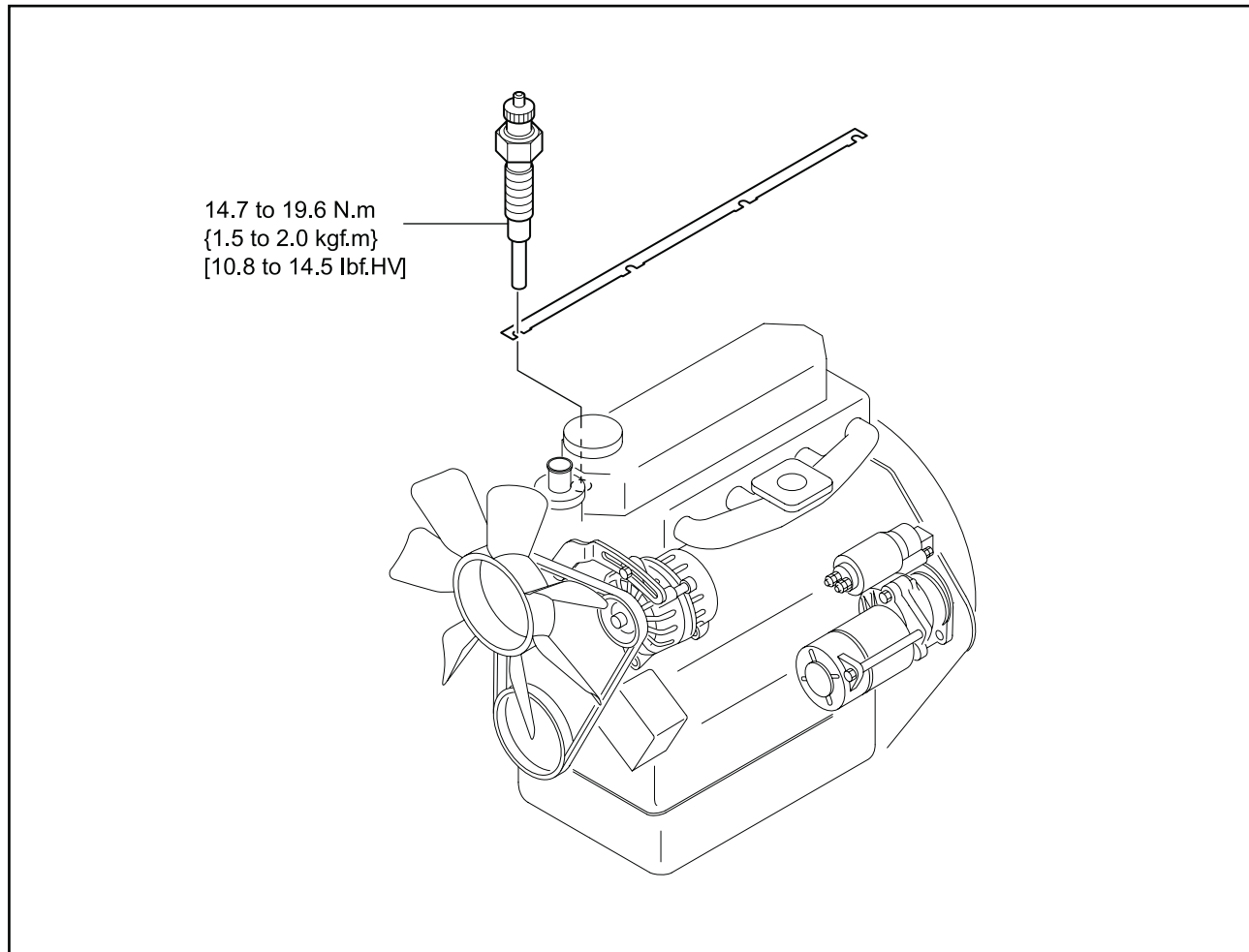

Installing glow plug

ELECTRICAL SYSTEM

3.2 Installing stop solenoid

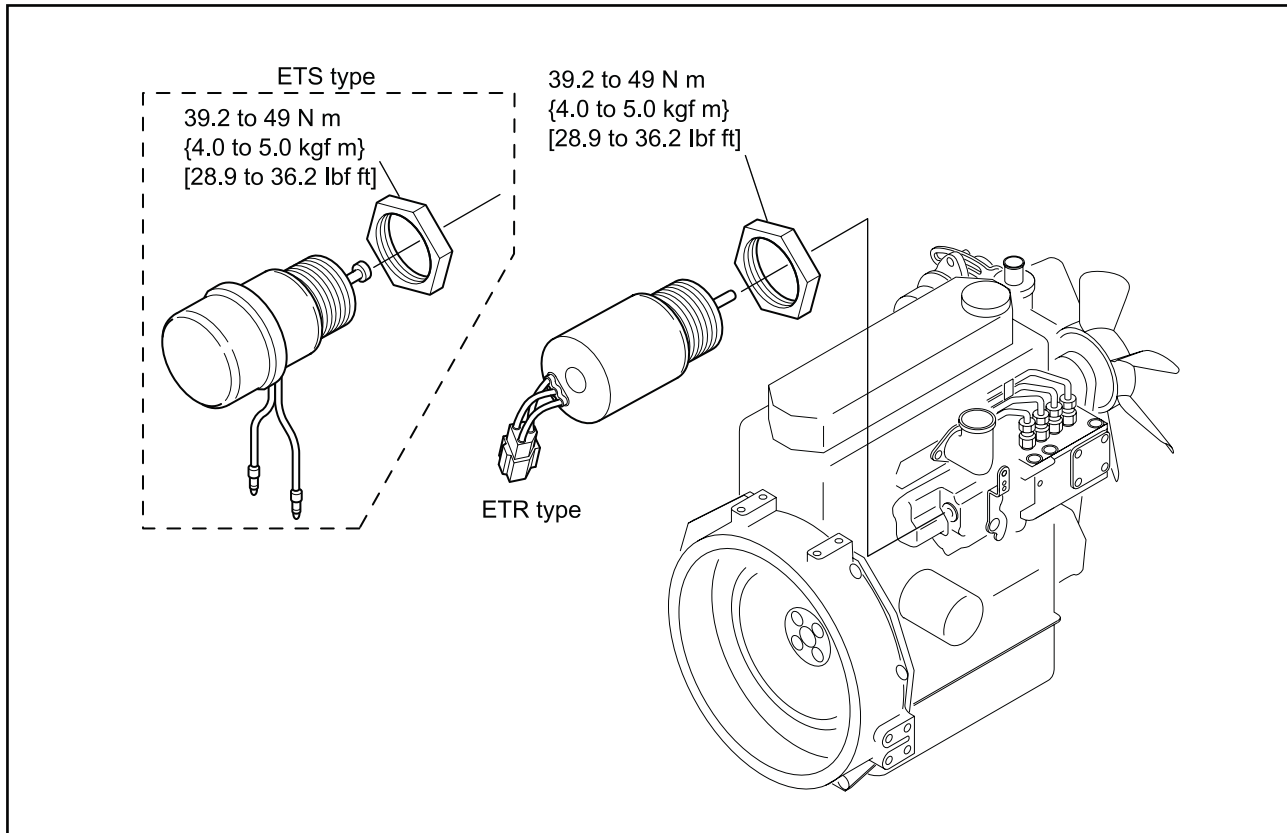

Installing stop solenoid

ELECTRICAL SYSTEM

3.3 Installing stop solenoid (ETR type)

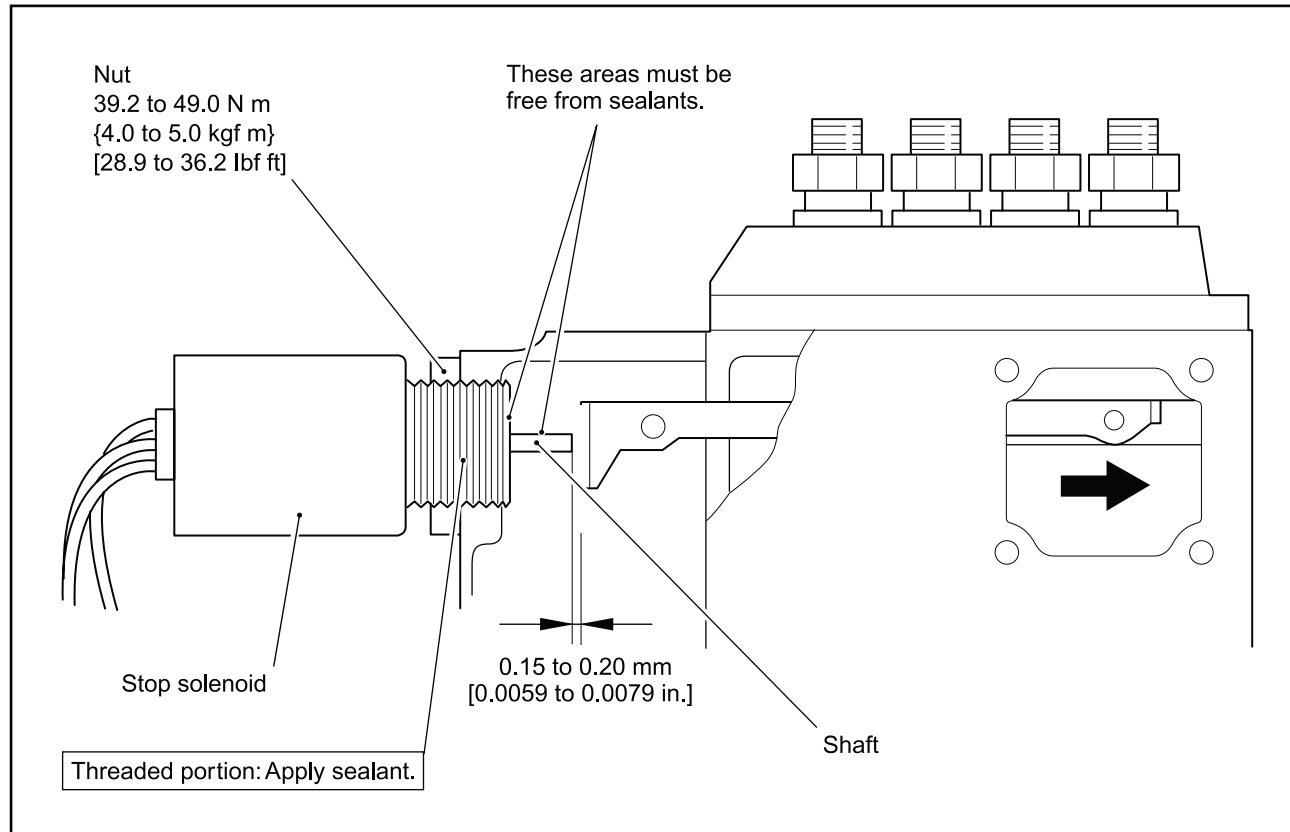

Installing stop solenoid (ETR type)

3.3.1 Procedure for installing stop solenoid (ETR type)

- (1) Apply a sealant to the threaded portion of the stop solenoid.

Note: Apply the sealant up to the position where the stop solenoid is screwed into the governor case.

Sealant or lubricant	THREEBOND 1212 or 1211
----------------------	------------------------

- (2) Temporarily reassemble the stop solenoid and the nut to the governor case.
- (3) Move the control rack of the fuel injection pump fully in the stop direction.
- (4) Screw in the stop solenoid until the shaft contacts the tie rod.
- (5) Turn the stop solenoid in the reverse direction by 30 to 45° from the above condition and temporarily tighten the nut.
- (6) Move the control rack side to side and make sure that there is play of approx. 0.15 to 0.20 mm [0.0059 to 0.0079 in.].
- (7) Tighten the nut to the specified torque.

3.3.2 Verification after reassembling (ETR type)

- (1) After starting the engine, turn the starter switch key to the OFF position, and make sure that the stop solenoid activates and the engine stops.
- (2) After starting the engine, make a short circuit between the terminal of the oil pressure switch and the switch body, and make sure that the engine stops.

ELECTRICAL SYSTEM

3.4 Installing stop solenoid (ETS type)

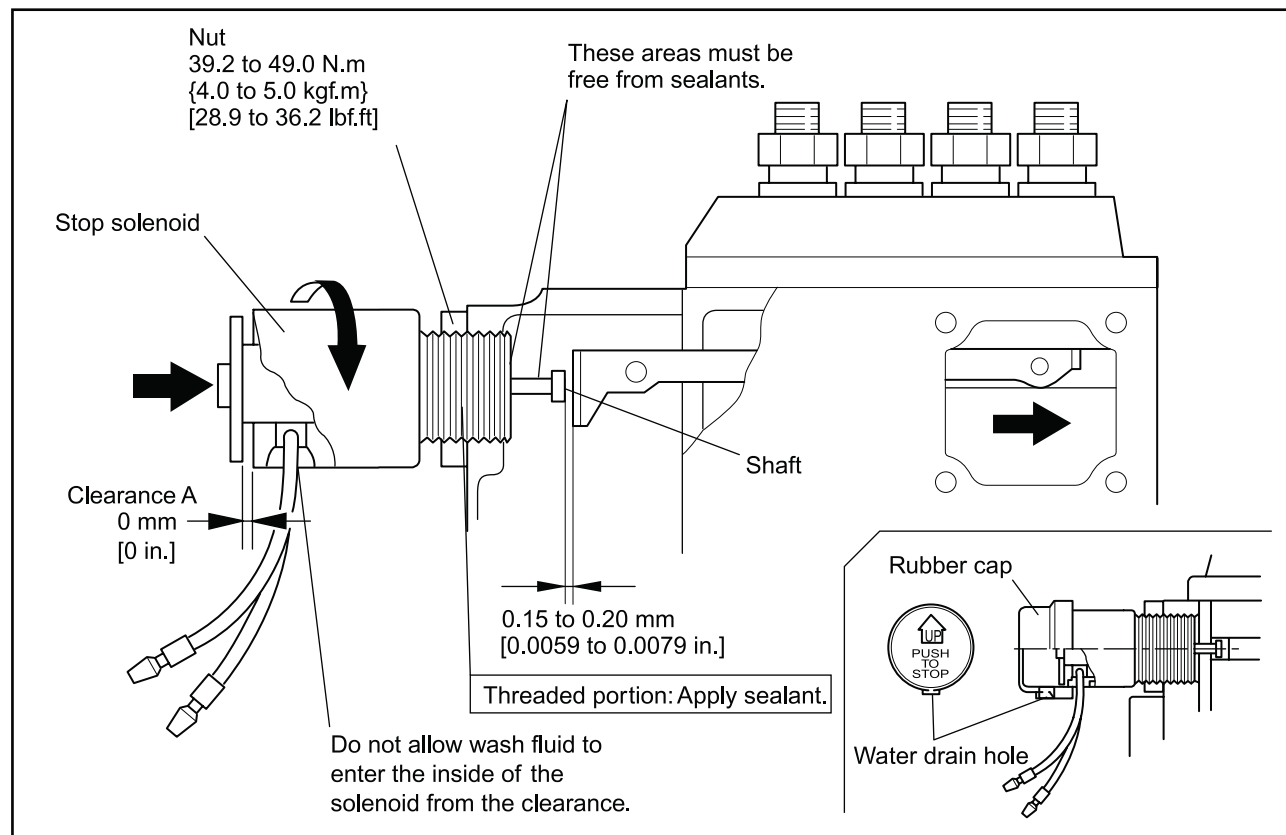

Installing stop solenoid (ETS type)

3.4.1 Procedure for installing stop solenoid (ETS type)

CAUTION

Do not allow wash fluid to enter the terminal and the inside (cord and shaft) of the solenoid.

- (1) Apply a sealant to the threaded portion of the stop solenoid.

Note: Apply the sealant up to the position where the stop solenoid is screwed into the governor case.

Sealant or lubricant	THREEBOND 1212 or 1211
----------------------	------------------------

- (2) Temporarily reassemble the stop solenoid and the nut to the governor case.
- (3) Move the control rack of the fuel injection pump fully in the stop direction.
- (4) Screw in the stop solenoid while pushing in the plunger until the shaft contacts the tie rod
At this time the clearance of A should be 0 mm [0 in.] (position where the plunger is also turned by screwing in the stop solenoid).
- (5) Turn the stop solenoid in the reverse direction by 30 to 45° from the above condition (at this time the clearance between the control rack and shaft is 0.15 to 0.20 mm [0.0059 to 0.0079 in.]) and tighten the nut to the specified torque.
- (6) Finally, reassemble the rubber cap with the arrow facing upward (water drain hole facing downward) as illustrated.

ELECTRICAL SYSTEM

3.4.2 Verification after reassembly (ETS type)

- (1) After starting the engine, turn the starter switch key to the OFF position, and make sure that the solenoid activates and the engine stops.
- (2) During engine start, turn the starter switch key to the ON position, and make sure that the solenoid activates and the engine enters a stopped state.
- (3) Turn the starter switch key from the OFF position to ON, and then to START position. Make sure that the solenoid activates with the key turned to ON and that the solenoid instantly stops to activate with the key turned to START.

ELECTRICAL SYSTEM

3.5 Installing alternator

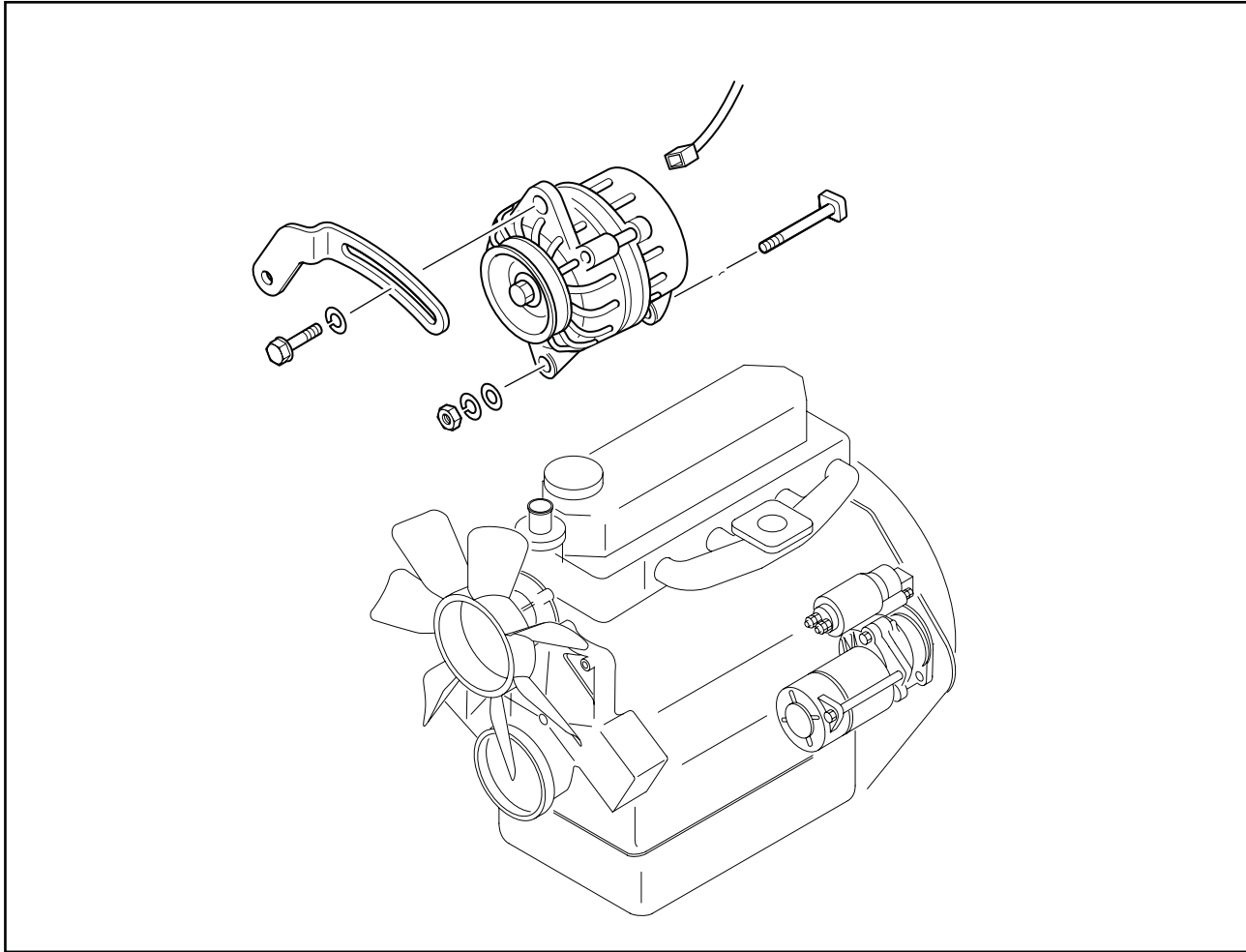

Installing alternator

ELECTRICAL SYSTEM

3.6 Installing starter

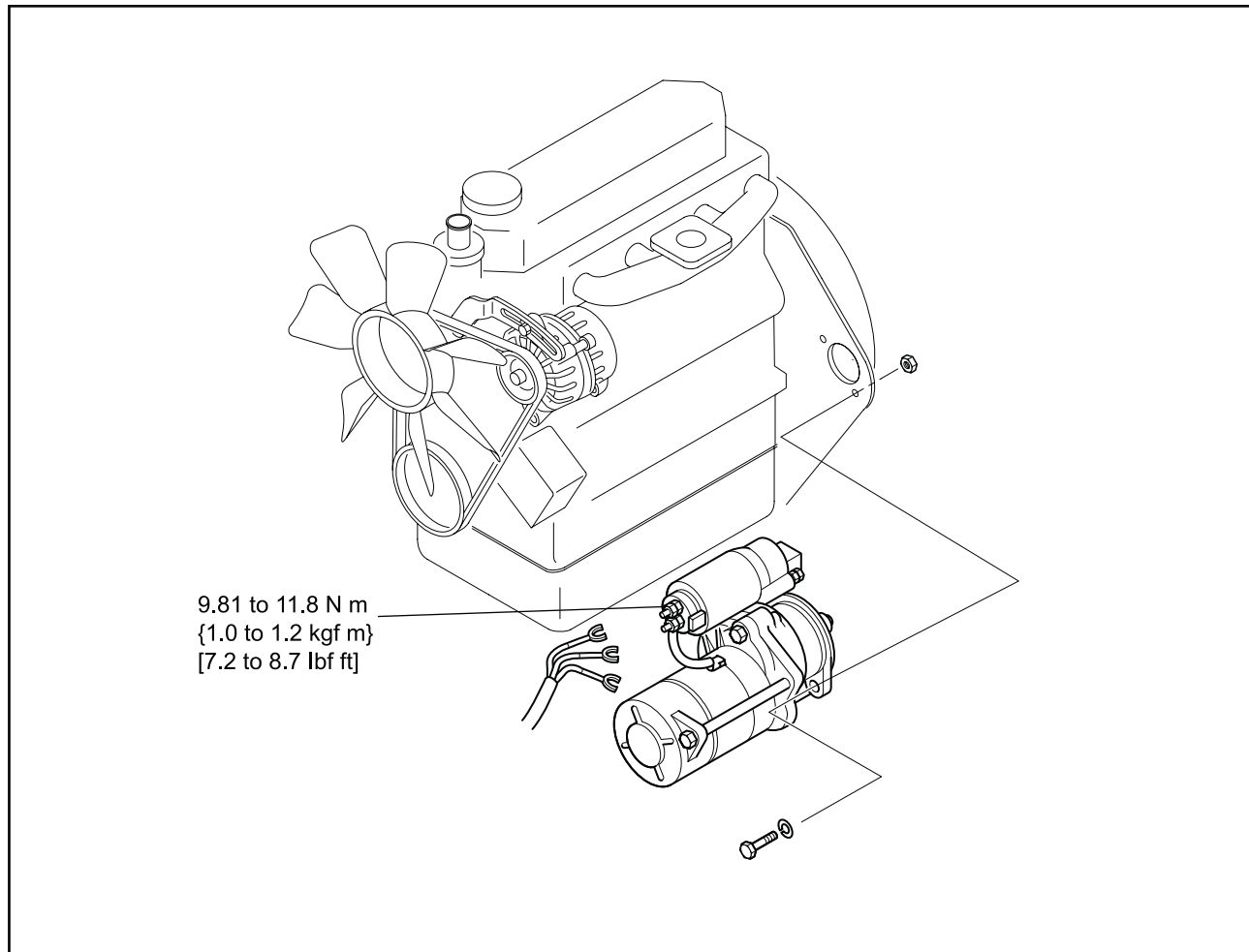

Installing starter

ADJUSTMENT AND OPERATION

1. Inspection and adjustment of engine	D-137
1.1 Inspecting and adjusting valve clearance	D-137
1.1.1 Preparation for valve clearance inspection	D-137
1.1.2 Inspecting valve clearance.	D-137
1.2 Inspecting fuel injection timing	D-138
1.3 Adjusting fuel injection timing	D-139
1.4 Inspecting and adjusting low idle speed and high idle speed	D-140
1.4.1 Preparation	D-140
1.4.2 Adjusting low idle speed.	D-140
1.4.3 Adjusting high idle speed	D-140
1.5 Bleeding fuel system.	D-141
1.5.1 Bleeding air from fuel filter	D-141
1.5.2 Bleeding air from fuel injection pump.	D-141
1.6 Adjusting V-belt tension.	D-141
2. Break-in operation.	D-142
2.1 Starting up.	D-142
2.2 Inspecting engine condition after starting up	D-142
2.3 Break-in operation time.	D-142
2.4 Inspection and adjustment after break-in operation	D-142
3. Performance test (JIS standard).	D-143
3.1 Engine equipment condition	D-143
3.2 Test items and purposes	D-143
3.2.1 Operation load test.	D-143
3.2.2 Continuous load test	D-143
3.2.3 Low idle test	D-143
3.3 Other inspections	D-143
3.4 Engine output adjustment	D-143
3.4.1 Standard atmospheric conditions.	D-143
3.4.2 Calculation of corrected power	D-144

ADJUSTMENT AND OPERATION

1. Inspection and adjustment of engine

1.1 Inspecting and adjusting valve clearance

1.1.1 Preparation for valve clearance inspection

- (1) Inspect and adjust the valve clearance when the engine is cold.
- (2) Slightly loosen cylinder head bolts and tighten them to the specified torque in the order as shown in the illustration.

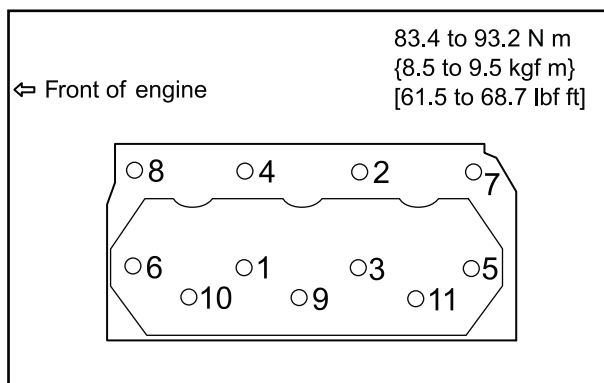

Tightening order of cylinder head bolts

1.1.2 Inspecting valve clearance

- (1) Set No. 1 cylinder to the top dead center in compression stroke.

This position is where the TDC mark on the crankshaft pulley aligns with the mark on the gear case.

Note: The compression top is where the rocker arm does not move when the crankshaft is rotated in the forward and backward direction by both 20° approx.

If the rocker arm moves, it is the top dead center in exhaust stroke. Rotate the crankshaft another full turn to set the No. 1 cylinder to the top dead center in compression stroke.

- (2) Start adjusting the valve clearance from the No. 1 cylinder and adjust the valve clearance of other cylinders according to the ignition order.

Note: To set the next cylinder to the compression top after adjustment of No. 1 cylinder, rotate the crankshaft in the forward direction (clockwise toward the timing gear case) by the angle corresponding to the number of cylinders.

- (3) Insert a thickness gauge between the rocker arm and bridge cap. Turn the adjusting screw while measuring the clearance, and adjust the clearance so that the thickness gauge can move with slight stiffness.
- (4) After adjustment, tighten the lock nut firmly. Then, check the clearance again.

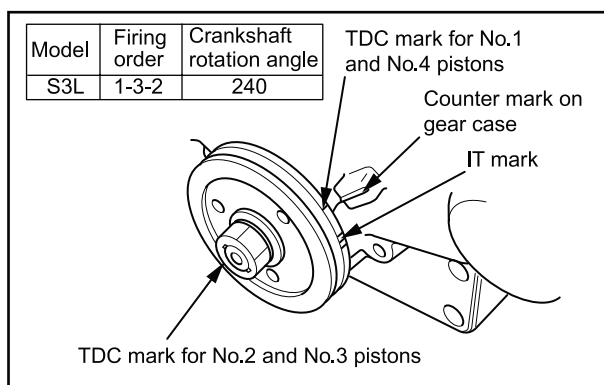

Timing mark

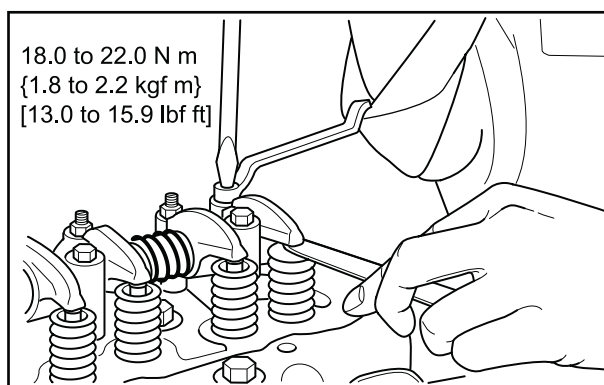

Adjusting valve clearance

Item		Standard
Valve clearance	Inlet	0.25 mm [0.0098 in.]
	Exhaust	0.25 mm [0.0098 in.]

ADJUSTMENT AND OPERATION

1.2 Inspecting fuel injection timing

CAUTION

To prevent the outflow of fuel, stop the fuel supply before removing the delivery valve.

The fuel injection timing varies with the output, speed and other engine specifications. Be sure to check the engine's specification sheet.

- (1) Remove the No. 1 fuel injection pipe.
- (2) Remove the No.1 delivery valve holder of the fuel injection pump.
- (3) Pull out the spring and delivery valve. Then do not remove the delivery valve seat.
- (4) Install the delivery valve holder.
- (5) Remove the tie rod cover.
- (6) Disconnect the tie rod from the control rack.
- (7) Set the control rack to the medium position of the operating range.
- (8) Feed fuel from the fuel hose and check that the fuel flows out from the delivery holder.
- (9) Rotate the crankshaft forward (clockwise). The fuel injection timing is the moment when the fuel stops flowing from the delivery valve holder outlet.

Note: When the fuel stops flowing, rotate the crankshaft backward (counterclockwise) to allow the fuel flowing again. And then, rotate the crankshaft forward (clockwise) to ensure the accurate timing when the fuel stops flowing.

- (10) It is normal that IT mark of the crankshaft pulley aligns the mark on the gear case at the position that fuel flow stopped.

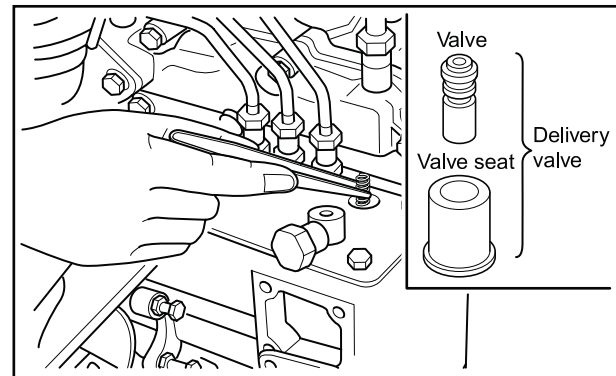

Removing delivery valve and spring

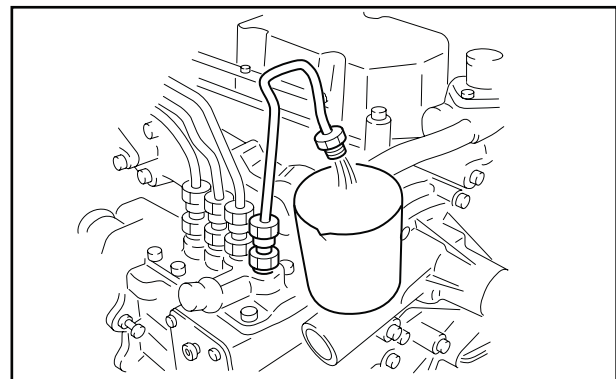

Fuel coming out

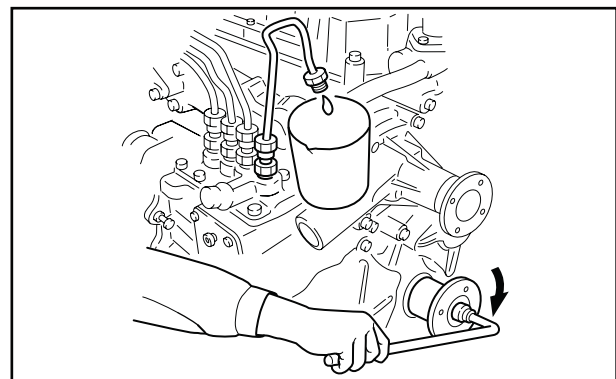

Fuel stops coming out

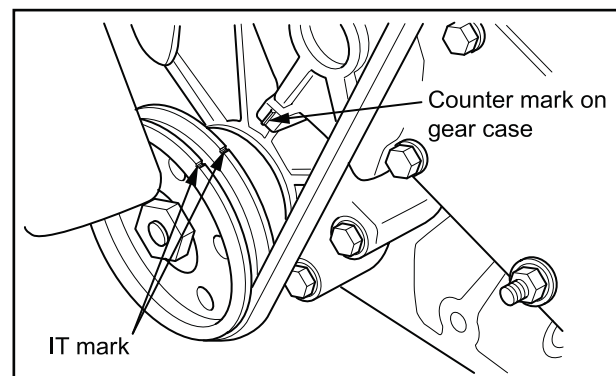

Timing mark

ADJUSTMENT AND OPERATION

1.3 Adjusting fuel injection timing

CAUTION

When using the shim, apply sealant to both side of the shim to prevent oil leakage.

- (1) If the fuel injection timing does not meet the specified value, increase or decrease the thickness of the fuel injection pump adjusting shim to adjust the timing. (adjusting value: standard value $\pm 1.5^\circ$)

Note: A change in thickness of the shim by 0.1 mm [0.004 in.] results in a change in the fuel injection timing by approx 1° . There are nine kinds of shim from 0.2 to 1.0mm [0.008 to 0.039 in.].

- (2) After adjusting, check that the fuel injection timing is properly adjusted.
- (3) Close the cock of the fuel filter, and reassemble the delivery valve, spring, fuel injection pipe.
- (4) With the delivery valve installed, check the fuel injection timing as follows:

Note: If the fuel injection pump and the engine are dirty, removing the delivery valve allows dirt and dust to enter the fuel injection pump.

- (5) Remove the tie rod cover and disconnect the tie rod from the control rack.
- (6) Set the control rack to the medium position in the operating range and then remove the No. 1 fuel injection pipe on the nozzle side. When the crankshaft is gradually rotated forward (clockwise), fuel begins to swell at the tip of the pipe. This timing is the fuel injection timing. In this case, the timing is delayed by 1° as compared to the normal fuel injection timing.

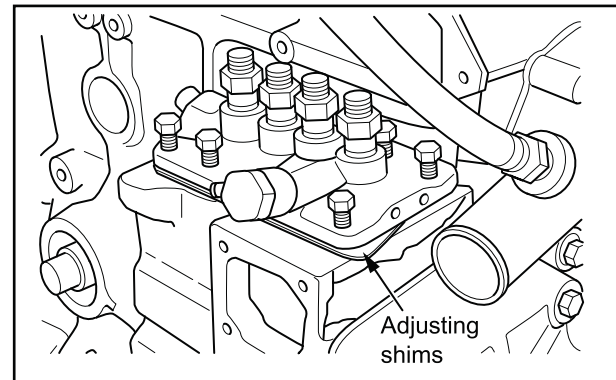

Shims for adjusting fuel injection timing

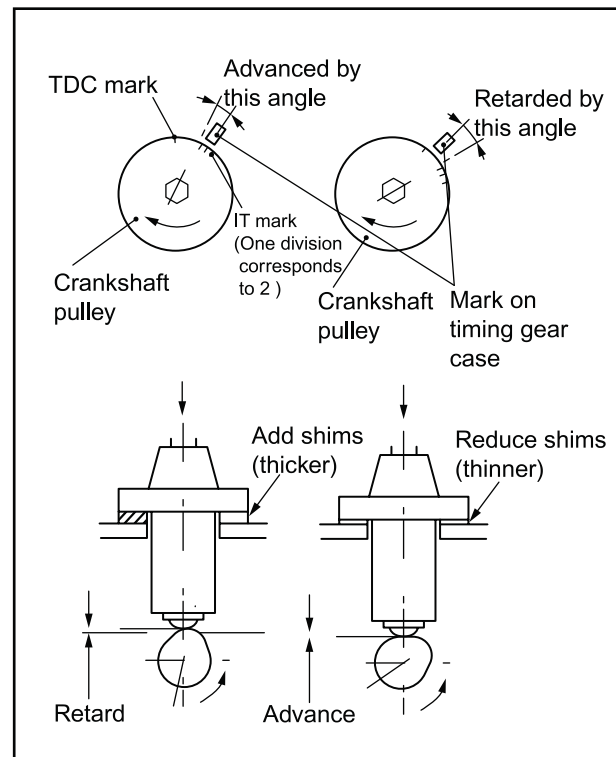

Adjusting fuel injection timing

ADJUSTMENT AND OPERATION

1.4 Inspecting and adjusting low idle speed and high idle speed

CAUTION

- (a) The minimum no-load speed (low idle speed) and the maximum no-load speed (high idle speed) of each engine have been checked on test bench and then their setting bolts have been sealed at the factory. Only the service shops designated by Mitsubishi are authorized to perform checking and adjustment of these settings.
- (b) Be sure to seal all the external stoppers in the same manner as they were sealed at the factory if adjustments have been made on the governor.
Whether the seals are intact or not has important bearing on the validity of claims under warranty. Be sure to seal all of the specified locations.
- (c) When inspecting and adjusting the governor, be prepared to operate the engine stop lever manually in anticipation of engine overrevving (running at an extremely high speed).

1.4.1 Preparation

- (1) Operate the engine to warm up until coolant temperature reaches 60°C or higher.
- (2) Make sure that valve clearance, fuel injection timing, nozzle opening pressure, spray condition, and oil sealing are normal.

1.4.2 Adjusting low idle speed

- (1) Loosen the lock nut of idling set bolt.
- (2) By turning the bolt, adjust the low idling speed.
- (3) Secure the set bolt with the lock nut.

1.4.3 Adjusting high idle speed

- (1) Loosen the lock nut of high speed set bolt.
- (2) By turning the bolt, adjust the high idling speed.
- (3) Secure the set bolt with the lock nut.

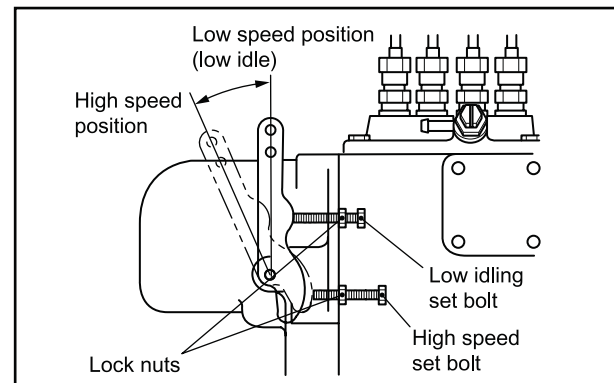

Adjusting engine speed

ADJUSTMENT AND OPERATION

1.5 Bleeding fuel system

WARNING

Completely wipe off any spilled fuel from air vent plug with a cloth, as spilled fuel can cause a fire.

Bleeding of the fuel system must be started from the place closest to the fuel tank: the fuel filter the first and the fuel injection pump the last.

1.5.1 Bleeding air from fuel filter

Cartridge type paper element

Loosen the air vent screw marked by the letter "1."

Tighten the air vent screw when fuel does not show air bubbles.

Loosen the air vent screw marked by the letter "2."

Tighten the air vent screw when fuel does not show air bubbles.

Note: Place the starter key in the ON position for the fuel pump type.

When the fuel supply is gravity type, fuel will flow into the filter by itself.

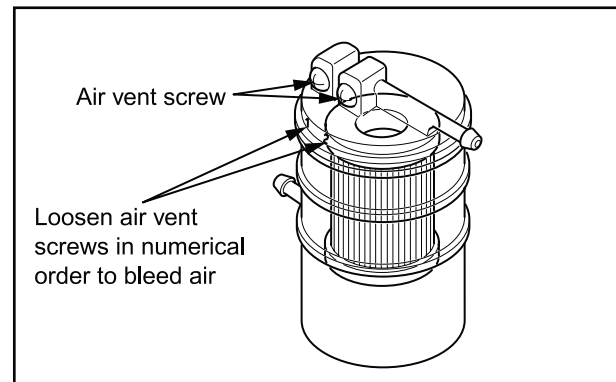

Bleeding air from fuel filter (cartridge type)

1.5.2 Bleeding air from fuel injection pump

Loosen the air vent screw of pump to discharge air in the fuel pipe and fuel injection pump.

Note: Air in the fuel injection pipe and fuel injection nozzle is automatically discharged by cranking of the engine.

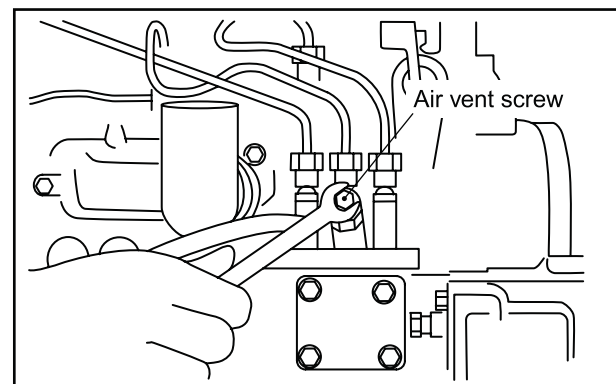

Bleeding air from fuel injection pump

1.6 Adjusting V-belt tension

- (1) Loosen the adjusting bolt and fixing bolt of the alternator. Loop the V-belt over the water pump pulley, alternator pulley and crankshaft pulley.
- (2) With the alternator pushed toward the V-belt tension side, tighten the adjusting bolt at an appropriate position.
- (3) Inspect the V-belt tension to make sure it is within the specified value.

Belt tension (with pushing force of approx. 98 N {10 kgf} [22 lbf])	Approx. 10 to 12 mm [0.39 to 0.47 in.]
---	---

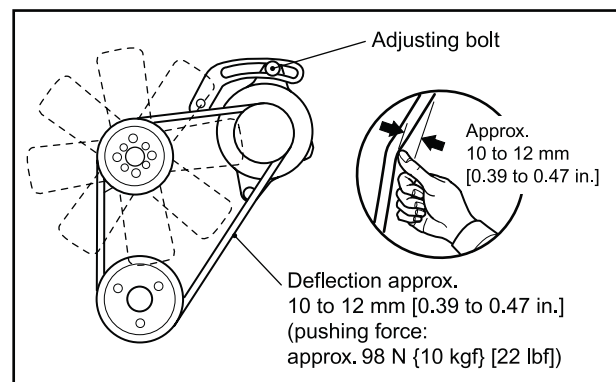

Adjusting deflection of V-belt

ADJUSTMENT AND OPERATION

2. Break-in operation

After the engine is overhauled, couple the engine to the dynamometer, and run the engine for break-in operation and inspection.

2.1 Starting up

- (1) Before starting the engine, check the levels of coolant, engine oil and fuel.
Bleed air from the fuel and cooling systems.
- (2) Stop the fuel supply, and crank the engine with the starter for about 10 seconds to lubricate the engine.
- (3) Move the control lever slightly in the fuel increase direction (but not to the "full injection" position), and then turn the starter switch key to the [START] position to start the engine.
- (4) After the engine is started, adjust the control lever to let the engine operate at a minimum no-load speed (low idle speed).
- (5) Turn the starter switch key to the [OFF] position and make sure that the engine is stopped.

2.2 Inspecting engine condition after starting up

During the break-in operation, check the followings.

If any abnormality is found, stop the engine, investigate the cause, and take appropriate measures.

- (1) The oil pressure must be within the specified value.
- (2) The coolant temperature must be within the specified value.
- (3) The engine must be free from any leakages such as oil, coolant and fuel. Pay special attention to oil leakage from the fitting face of turbocharger lube oil pipe.
- (4) Check for an abnormal noise.

Note: Knocking noise will disappear as the coolant temperature rises.

- (5) Check for the color of smoke and odors.

2.3 Break-in operation time

The relationship between the load in break-in operation and the operation time is as shown below.

Break-in operation time				
	Engine speed (min ⁻¹)		Load	Duration (min)
1	Low rotation speed	600 to 900	No-load	5
2	Medium rotation speed	1000 to 1200	No-load	5
3	High rotation speed	1400 to rated speed	No-load	10
4	Rated speed		25 %	10
5			50 %	10
6			75 %	30
7			100 %	20

Note: The table above is provided solely for reference purpose. Run the engine at appropriate speed and load for the break-in operation of your engine. Be sure to perform break-in operation after overhaul or installation.

2.4 Inspection and adjustment after break-in operation

- (1) Valve clearance adjustment
- (2) Ignition timing inspection
- (3) Exterior bolt and nut tightness check

ADJUSTMENT AND OPERATION

3. Performance test (JIS standard)

The following describes the procedures specified in "Earth moving machinery - Engines - Part 1: Test code of net power (JIS D0006-1)" and "Earth moving machinery - Engines - Part 2: Standard format of specifications and testing methods of diesel engines (JIS D0006-2)."

Other test items may be required in some applications. All test results should be evaluated comprehensively in order to determine the engine performance.

3.1 Engine equipment condition

The engine must be equipped with standard auxiliary devices such as cooling fan, air cleaner and alternator.

3.2 Test items and purposes

3.2.1 Operation load test

Conduct this test to evaluate the engine output, torque, fuel consumption rate and governor performance under various load conditions.

3.2.2 Continuous load test

Operate the engine continuously for 10 hours at 90% load (continuous load application) of nominal net brake power while the engine speed is maintained at revolutions corresponding to the nominal brake power. In this test, evaluate the fuel consumption rate and operating condition, and confirm that the engine is capable of continuous operation.

3.2.3 Low idle test

Conduct this test to confirm that the engine can operate stably at the specified low idle speed.

3.3 Other inspections

Check for gas, coolant and oil leaks; abnormal odors; and hunting. Make adjustment as needed.

3.4 Engine output adjustment

Diesel engine output is affected by atmospheric pressure, temperature and humidity. Therefore, correction calculations must be performed to obtain the value of engine output under the standard atmospheric conditions.

3.4.1 Standard atmospheric conditions:

Base temperature: 298 K (25 C) [77°F]

Total pressure: 100 kPa (750 mmHg)

Dry pressure: 99 kPa (743 mmHg)

ADJUSTMENT AND OPERATION

3.4.2 Calculation of corrected power

Multiply the measured brake power or torque by the calculated diesel engine correction factor to obtain a corrected value.

If the applicable range of the correction formula is exceeded, indicate the corrected values and record the test conditions on the test record.

Calculation output = Correction factor (α_c) x Measured brake power

• Atmospheric conditions during test

Temperature(T): 283K (10 Deg C) [50 Deg F] $\leq T \leq 313K$ (40 Deg C) [104 deg F]
 Dry atmospheric pressure(P_d): 80kPa (600 mmHg) $\leq P_d \leq 110$ kPa (825 mmHg)

$\alpha_c = (f_a)^{f_m}$ f_a : Atmospheric factor f_m : Engine factor

• Range of correction equation use

The range of correction factor α_c is as follows:
 $0.9 \leq \alpha_c \leq 1.1$

Calculation of correction factor(f_a)

- Natural aspiration engine and engine with mechanically driven air charger

$$f_a = \left(\frac{99}{P_d} \right) \left(\frac{T}{298} \right)^{0.7}$$

- Turbocharged engine without air cooler or with air-to-air cooler

$$f_a = \left(\frac{99}{P_d} \right)^{0.7} \left(\frac{T}{298} \right)^{1.2}$$

- Turbocharged engine with air-to-liquid cooler

$$f_a = \left(\frac{99}{P_d} \right)^{0.7} \left(\frac{T}{298} \right)^{0.7}$$

Calculation of engine factor f_m

$$f_m = 0.036q_c - 1.14$$

q_c : corrected fuel supply volume

$$q_c = \frac{q}{r} = \frac{(z) \times \text{Fuel Flow Rate (g/s)}}{\text{min}^{-1}}$$

$z = 120000$ (4- Cycle engine)

r : Ratio between pressure at turbocharger or air cooler outlet and atmospheric pressure

$r = 1$ (natural aspiration engine)

• Applicable range of engine factor f_m

$37.2 \leq q_c \leq 65$ mg/l (cycle)

$q_c \leq 37.2$ mg/l (cycle): $f_m = 0.2$ (constant)

$0.65 / (l\text{-cycle}) \leq q_c \leq 65$ mg/l (cycle): $f_m = 1.2$ (constant)

TROUBLESHOOTING

1. Troubleshooting	D-146
1.1 Before troubleshooting	D-146
1.2 Starting trouble	D-147
1.2.1 Check items before troubleshooting	D-147
1.2.2 Problem: Starting trouble	D-147
1.3 Knocking	D-148
1.3.1 Check items before troubleshooting	D-148
1.3.2 Problem: Knocking	D-148
1.4 Overheating	D-149
1.4.1 Check items before troubleshooting	D-149
1.4.2 Problem: Overheating	D-149
1.5 Excessive black smoke	D-150
1.5.1 Check items before troubleshooting	D-150
1.5.2 Problem: Excessive black smoke	D-150
1.6 Idling malfunction	D-151
1.6.1 Check items before troubleshooting	D-151
1.6.2 Problem: Unstable idling	D-151
1.7 Low output	D-152
1.7.1 Check items before troubleshooting	D-152
1.7.2 Problem: Low output	D-152

TROUBLESHOOTING

1. Troubleshooting

1.1 Before troubleshooting

CAUTION

- (a) For the fuel injection pump, the injection quantity of each cylinder can be measured only with a pump tester. Do not adjust or disassemble the fuel injection pump even during troubleshooting unless absolutely necessary.
- (b) To inspect the combustion state of each cylinder, loosen the fuel injection pipe of any cylinder to stop injection, and compare the extent of a drop in the engine speed with that of other cylinders

- (1) Troubles of the diesel engine often occur in combination of various problem causes, and therefore it is often very difficult to determine the defect from a problem phenomenon.

Especially a similar phenomenon occurs in troubles of the fuel injection pump, fuel injection nozzles and compression pressure. It is, therefore, necessary to conduct a careful study to determine the cause.

From the reason above, troubleshooting described in this section is summarized as the inspecting order from items which are more likely to cause problems or items easy to inspect in sequence.

- (2) The diesel engine has the following characteristics from its structure and combustion system. It is necessary to fully understand these characteristics before performing troubleshooting.
 - The engine produces unique combustion noise (diesel knock) in the normal condition.
 - The engine discharges slight black smoke at heavy load.
 - High compression and high torque cause vibration on a single unit of the engine.
 - Slight hunting is caused during acceleration and deceleration.

TROUBLESHOOTING

1.2 Starting trouble

1.2.1 Check items before troubleshooting

- (1) Clogging of air cleaner element
- (2) Coagulation of engine oil
- (3) Use of poor quality fuel
- (4) Drop in cranking speed

1.2.2 Problem: Starting trouble

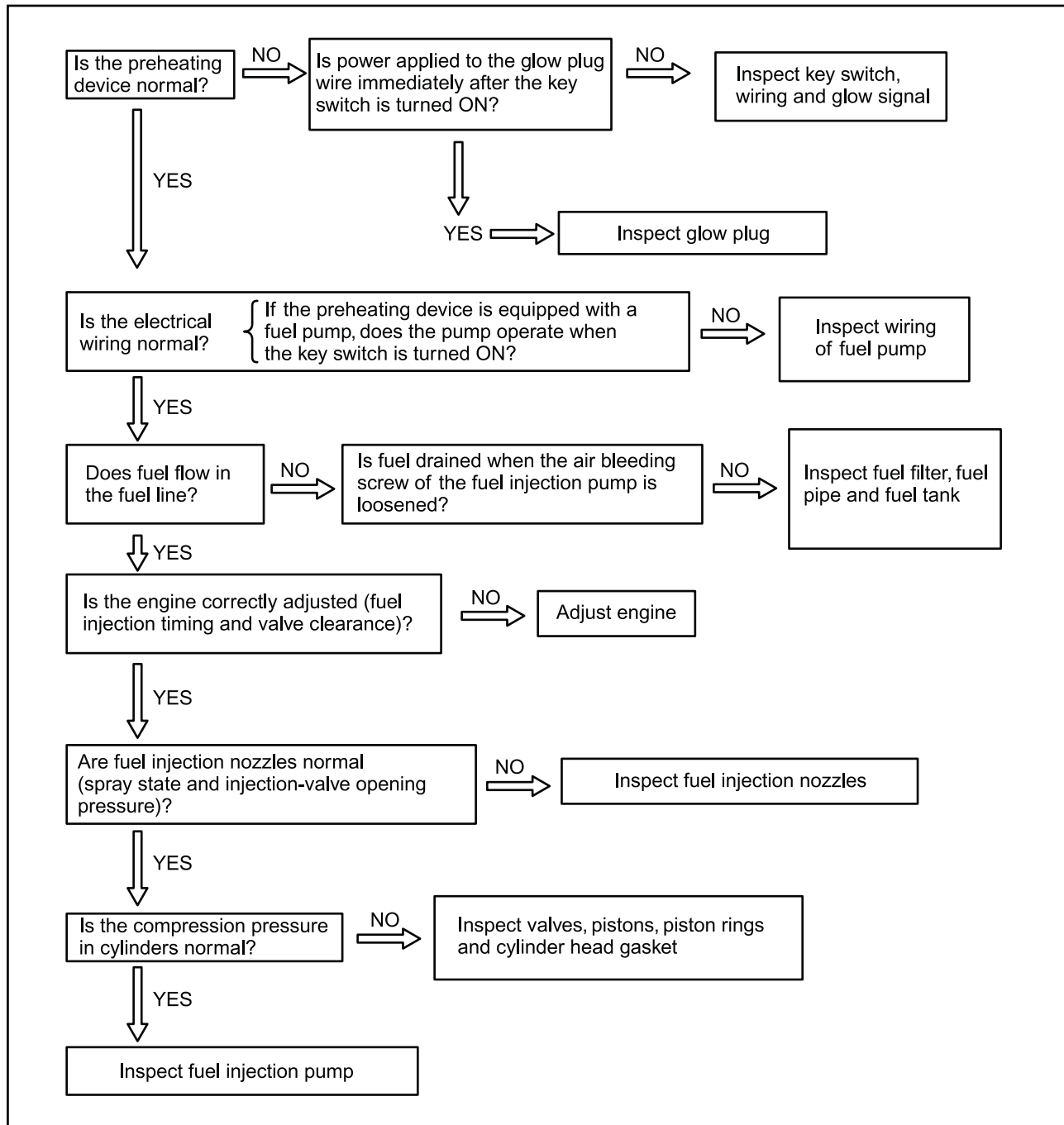

Problem: Starting trouble

TROUBLESHOOTING

1.3 Knocking

The diesel engine rotates producing unique combustion noise (diesel knock) due to its combustion system. This knock noise is normal unless it is especially loud.

1.3.1 Check items before troubleshooting

(1) Clogging of air cleaner element

(2) Use of poor quality fuel (low cetane number fuel such as kerosene)

1.3.2 Problem: Knocking

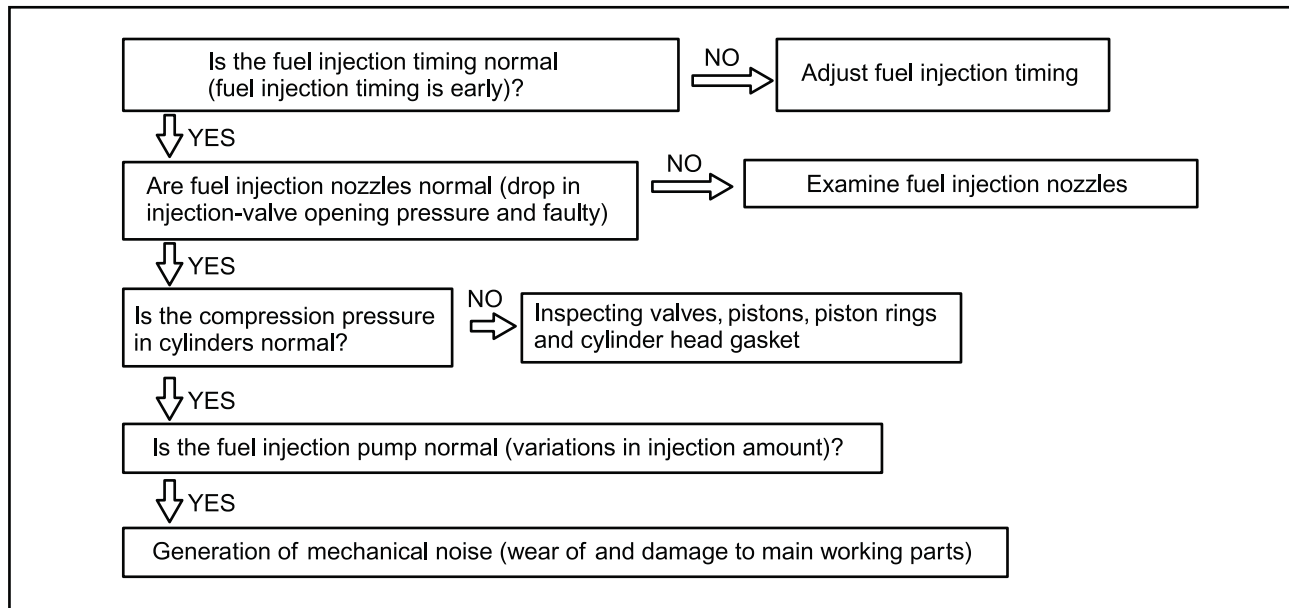

Problem: Knocking

TROUBLESHOOTING

1.4 Overheating

1.4.1 Check items before troubleshooting

- (1) Quantity and leakage of coolant
- (2) Loosening of fan belt
- (3) Clogging of radiator fins
- (4) Concentration of LLC
- (5) Clogging of muffler
- (6) Quantity and degradation of engine oil
- (7) Swirling of cooling air
- (8) Thermostat malfunction

1.4.2 Problem: Overheating

Overheat often occurs by engine load mismatching when the engine is set up.

If the engine itself is normal and overheat occurs, measure the ambient and coolant temperatures in the loaded condition (thermostat full open).

If the temperature difference is greater than 60°C [140°F], the investigation into other components as well as the engine is suggested.

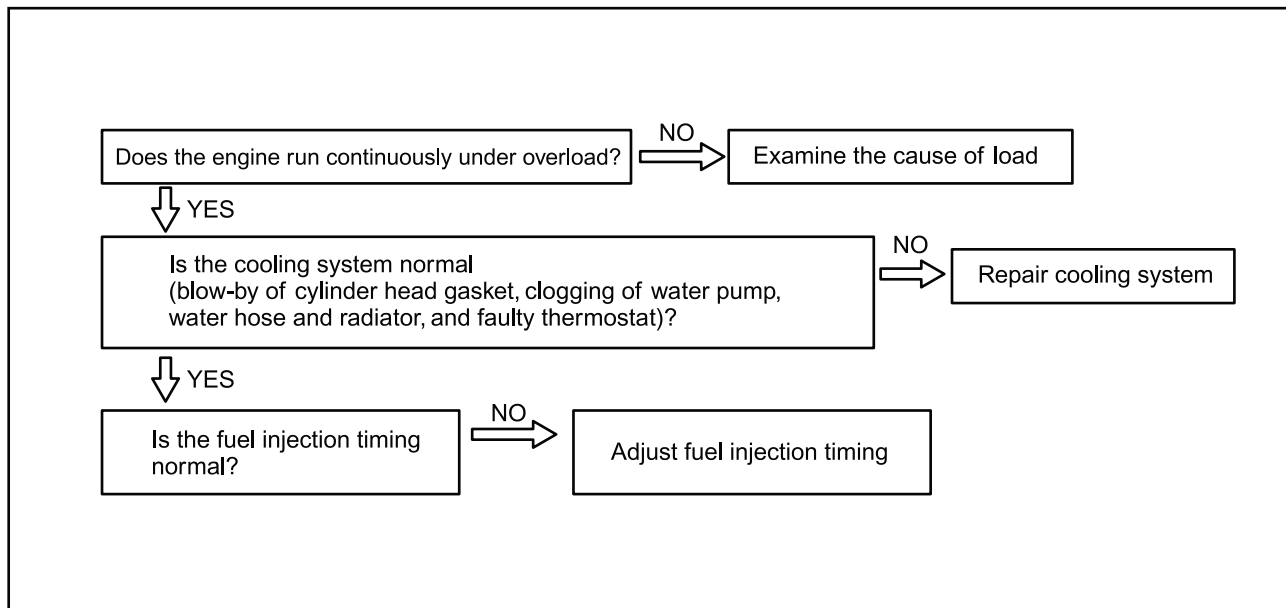

Problem: Overheating

TROUBLESHOOTING

1.5 Excessive black smoke

1.5.1 Check items before troubleshooting

- (1) Clogging of air cleaner element
- (2) Use of poor quality fuel
- (3) Overload

1.5.2 Problem: Excessive black smoke

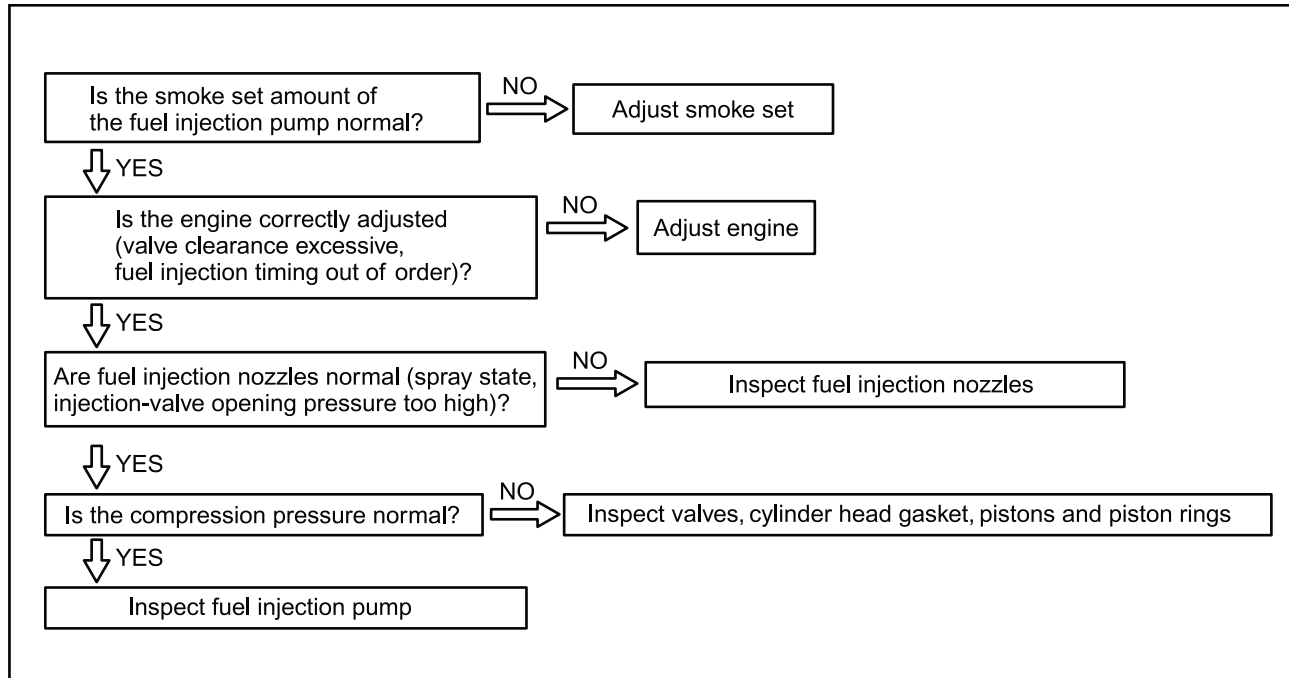

Problem: Excessive black smoke

TROUBLESHOOTING

1.6 Idling malfunction

1.6.1 Check items before troubleshooting

- (1) Engine control system malfunction
- (2) Viscosity of engine oil too high
- (3) Use of poor quality fuel

1.6.2 Problem: Unstable idling

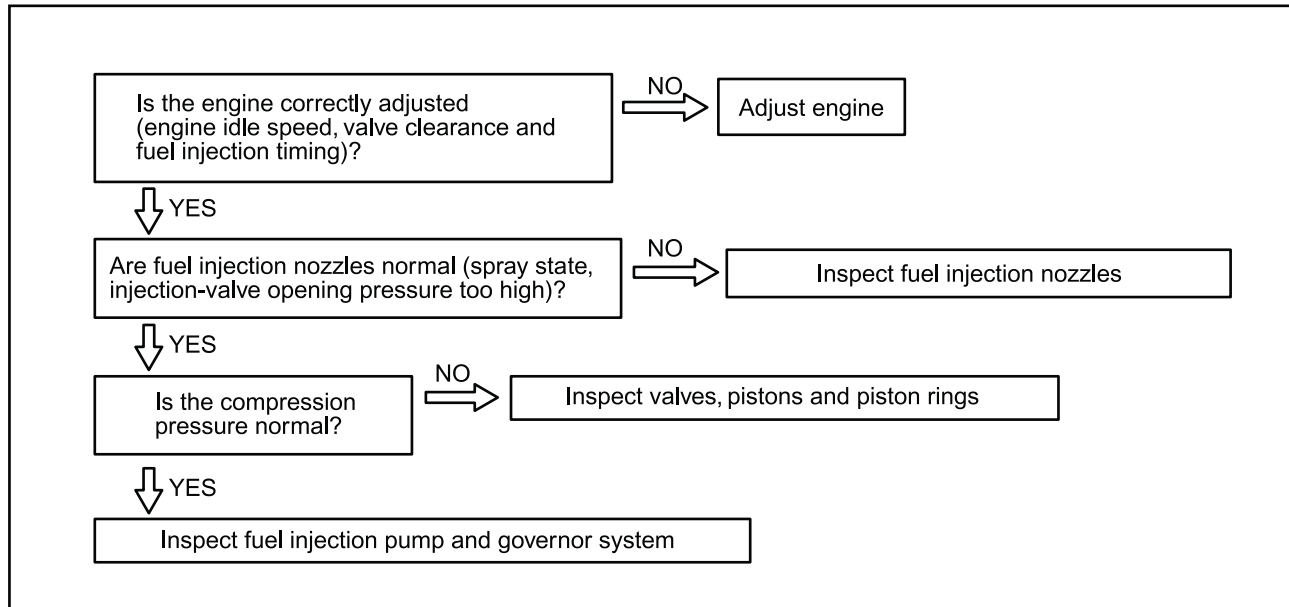

Problem: Unstable idling

TROUBLESHOOTING

1.7 Low output

1.7.1 Check items before troubleshooting

- (1) Seizure of engine moving parts
- (2) Viscosity of engine oil too high
- (3) Use of poor quality fuel
- (4) Clogging of air cleaner element
- (5) Clogging of muffler
- (6) Powertrain malfunction

1.7.2 Problem: Low output

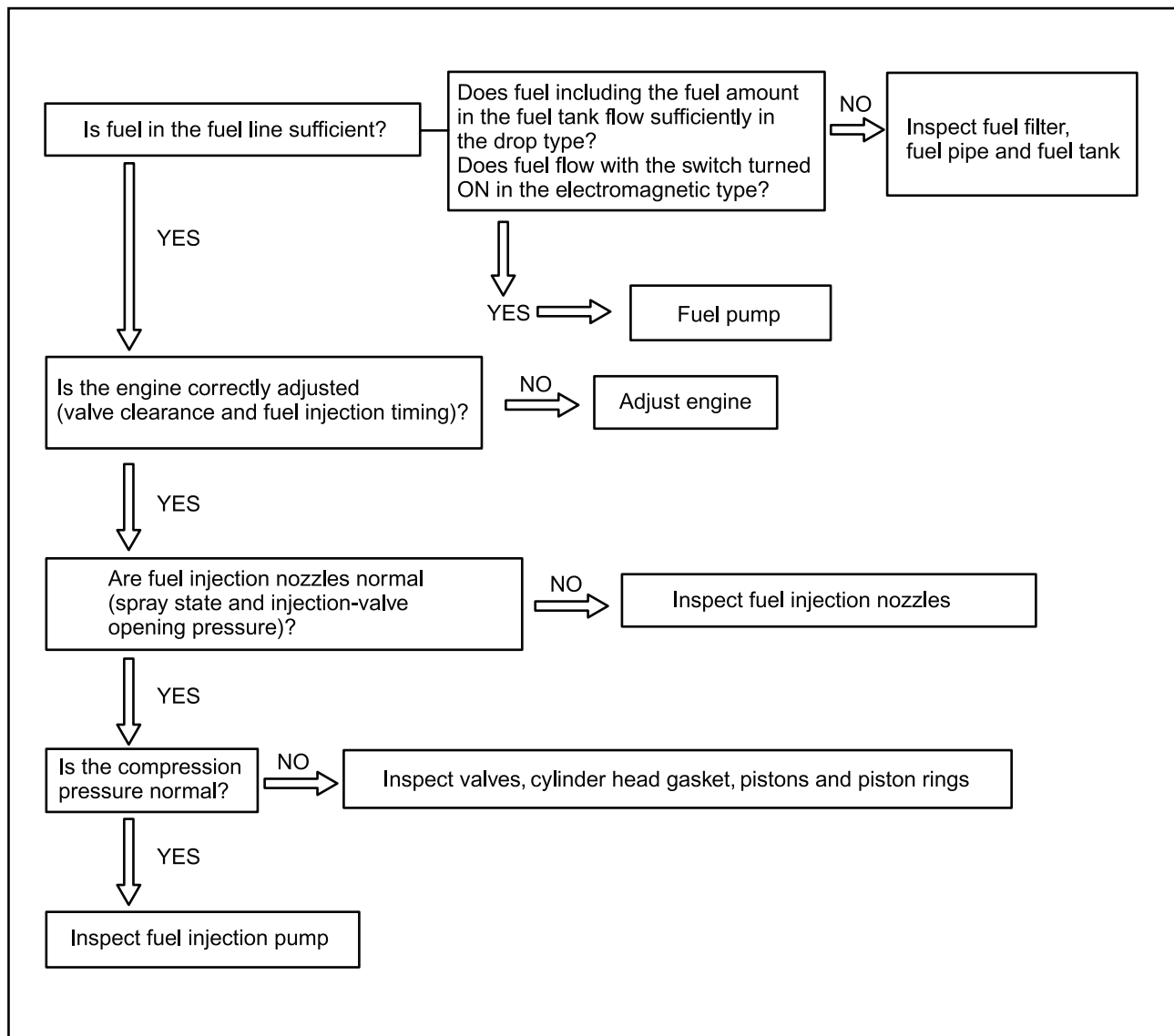

Problem: Low output

The top-left and bottom-left corners of the page feature a decorative pattern of overlapping, semi-transparent hexagons in shades of light blue and grey. The background is divided into three main sections: a white upper-right triangle, a light grey lower-left triangle, and a dark teal triangular section in the top-right and bottom-right corners.

SUMMIT™
—TRACTORS—